

Surface sensing thermostat with limiter

PRODUCT OVERVIEW

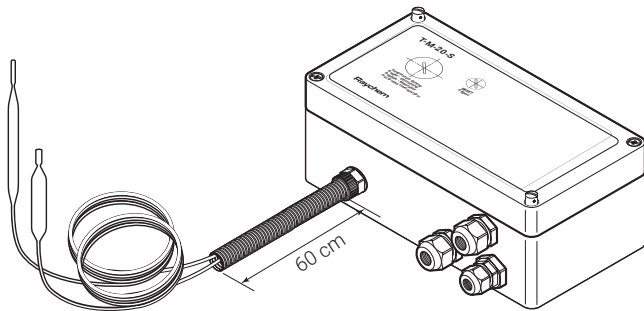

A surface sensing thermostat providing temperature control and temperature limiter in safe areas. The high limit cut-out prevents the heating system exceeding a preset maximum temperature should the control function fail to operate or an unsafe process temperature occur.

Temperature set point adjustment and limiter reset can be completed, without opening the enclosure, via removable plugs in the lid.

Both 2 meter long stainless steel fluid filled bulb and capillary are protected at the enclosure by a flexible conduit.

Direct connection of the heating cable is possible.

The thermostat is available in 3 temperature ranges. 0-100°C; 0-200°C; 50-300°C.

PRODUCT SPECIFICATIONS

Dimensions (in mm)

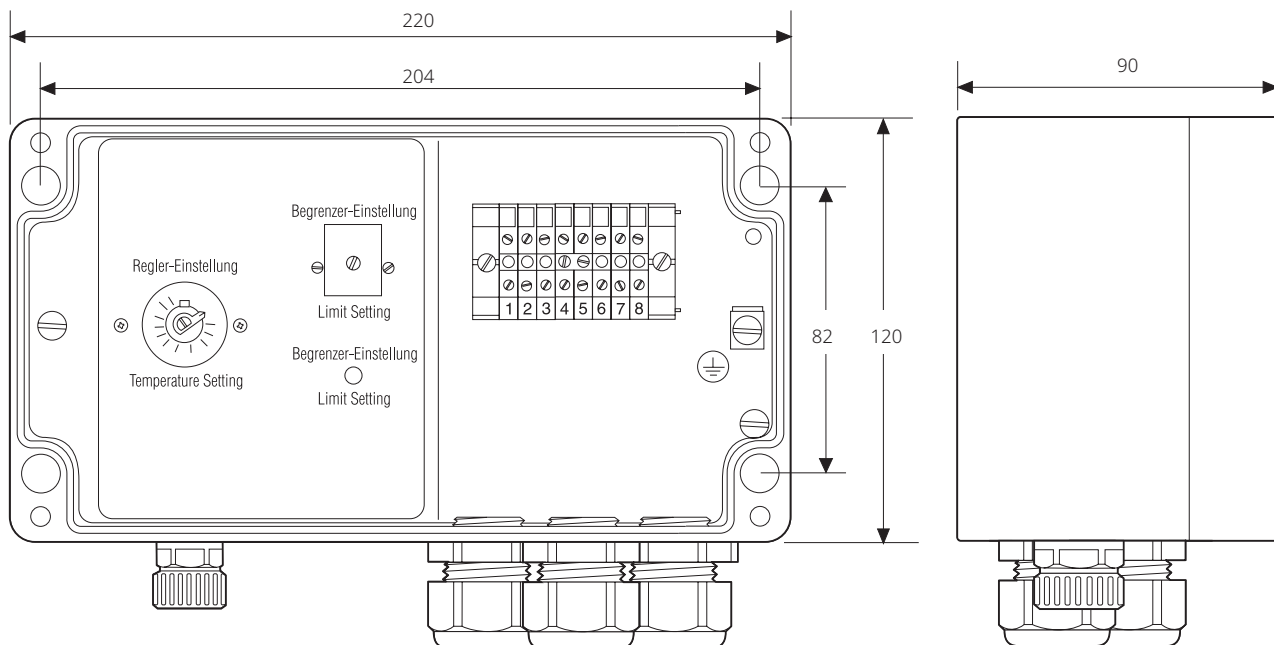

Connection details

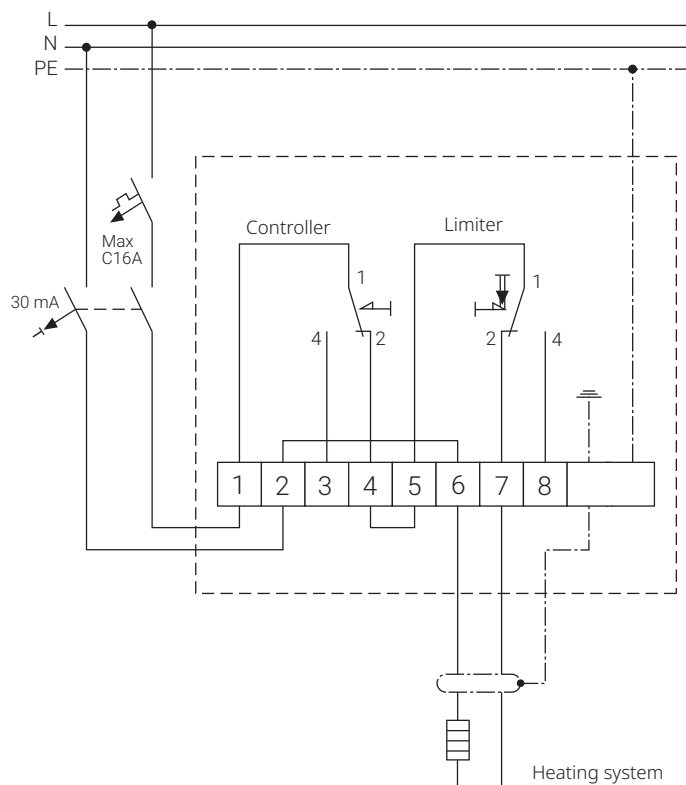

Technical details

		T-M-20-S/0+100C	T-M-20-S/0+200C	T-M-20-S/+50+300C
Max rated voltage (nom)		230 Vac	230 Vac	230 Vac
Temperature setting	Controller	0°C to +100°C	0°C to +200°C	+50°C to +300°C
	Limiter	+50°C to +150°C	+80°C to +200°C	+150°C to +350°C
Switching type		Single pole change over (SPDT) 100,000 cycles at 16 A (controller) 500 cycles at 10 A (limiter)		
Switching capacity	Controller	Max 16 A at 230 Vac	Max 16 A at 230 Vac	Max 16 A at 230 Vac
	Limiter	Max 16 A at 230 Vac	Max 16 A at 230 Vac	Max 16 A at 230 Vac
Hysteresis/Differential		2.5% of temperature range	2.5% of temperature range	2.5% of temperature range
Accuracy		±1.5% of setpoint in upper third of temperature range (at 22°C ambient)		
Setting		Internal dial, through lid	Internal dial, through lid	Internal dial, through lid
Terminal size		4 mm ²	4 mm ²	4 mm ²
Ambient operating temp. range		-20°C to +80°C	-20°C to +80°C	-20°C to +80°C

Output parameters

Control relay	Change-over switch (SPDT)
Limiter relay	Change-over switch with possibility for external alarm (SPDT)

Enclosure

Protection	IP65	IP65	IP65
Dimension	222 x 120 x 90 mm	222 x 120 x 90 mm	222 x 120 x 90 mm
Materials body and lid	Grey, polyester enclosure	Grey, polyester enclosure	Grey, polyester enclosure
Lid fixing	4 captive screws, stainless steel		
Entries	3 entries: 1 x M25 Reducer M25 (M)/M20 (F) incl. M20 gland (Ø 8–13 mm) 1 x M20 gland (Ø 8–13 mm) 1 x M20 gland (Ø 8–13 mm)		

Temperature sensor

		T-M-20-S/0+100C	T-M-20-S/0+200C	T-M-20-S/+50+300C
Type		Fluid filled capillary, 2 meter long		
Dimensions				
Controller	Ø Length sensing element	8 mm 90 mm	8 mm 82 mm	8 mm 60 mm
Limiter	Ø Length sensing element	6 mm 52 mm	6 mm 57 mm	6 mm 85 mm
Material		V4A Stainless Steel	V4A Stainless Steel	V4A Stainless Steel
Exposure temperature	Controller Limiter	+125°C +175°C	+230°C +230°C	+330°C +365°C
Minimum bending radius		10 mm for capillary, the sensor cannot be bent		

Mounting method

Support bracket	SB-120 or surface mount
Storage temperature	-50°C to +50°C

APPROVALS

For use in ordinary area.

Product certification



ORDERING INFORMATION

Ordering References	Part Number (PN)	Weight
T-M-20-S/0+100C	1244-022642	1.9 kg
T-M-20-S/0+200C	1244-022643	1.9 kg
T-M-20-S/+50+300C	1244-022644	1.9 kg

Meaning of reference: Raychem T-M-20-S/+x+y

T = thermostat

M = mechanical thermostat

20 = control thermostat + limiter

S = surface sensing

x = min temperature of control range

y = max temperature of control range

North America

Tel +1 800 545 6258
info@chemelex.com

Latin America

Tel +1 713 868 4800
info@chemelex.com

Europe, Middle East, Africa, India

Tel +32 16 213 511
Fax +32 16 213 604
info@chemelex.com

Asia Pacific

Tel +86 21 2412 1688
infoAPAC@chemelex.com

chemelex
excellence is everything

Raychem Tracer Pyrotenax Nuheat