

Temperature sensor for ordinary area

PRODUCT OVERVIEW

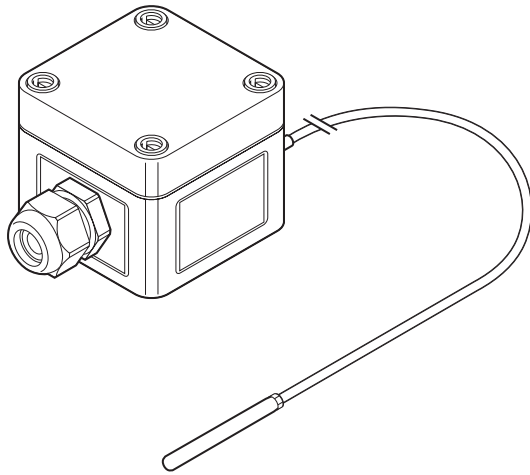

2 wire Raychem Pt100 sensor with glass fiber reinforced polycarbonate junction box for installation in ordinary area.

PRODUCT SPECIFICATIONS

Sensor

Type	Pt100 (2 wire) DIN IEC 751, Class B
Material	Tip: stainless steel Extension cable: silicone
Temperature measuring range	-50°C to +180°C
Temperature range extension cable	-50°C to +180°C (+215°C maximum 1000 hrs), max. exposure temp. tip: +400°C
Length	2 m
Diameter	Extension cable ca 4.6 mm, tip ca 6.0 mm
Minimum bending radius	Extension cable: 5 mm, the measuring tip should not be bent

Enclosure

Ingress protection	IP66
Material	Glass fiber reinforced polycarbonate (gray)
Dimensions	Width = 65 mm Height = 65 mm Depth = 57 mm
Cable gland	M20 (polyamide) suitable for cable diameters ranging from 10 mm to 14 mm
Operating temperature	-30°C to +80°C
Lid sealing gasket material	CFC-free Polyurethane
Cover screws	Plastic
Mounting	For pipe mount use JB-SB-26 wall mount surface mount via moulded holes at 50 x 50 mm

Installation and connection

Terminals	3 front entry spring-type terminals (terminals 2 and 3 are bridged)
Terminal sizing	Terminals suitable for cables from 0.15 mm to 2.5 mm ²

APPROVALS

For use in ordinary area

Product certification



ORDERING INFORMATION

Part Description	MONI-PT100-NH
PN (Weight)	140910-000 (0.22 kg)

North America

Tel +1 800 545 6258
info@chemelex.com

Latin America

Tel +1 713 868 4800
info@chemelex.com

Europe, Middle East, Africa, India

Tel +32 16 213 511
Fax +32 16 213 604
info@chemelex.com

Asia Pacific

Tel +86 21 2412 1688
infoAPAC@chemelex.com

chemelex
excellence is everything

Raychem Tracer Pyrotenax Nuheat