

Integrated junction box for direct connection of XPI heaters

PRODUCT OVERVIEW

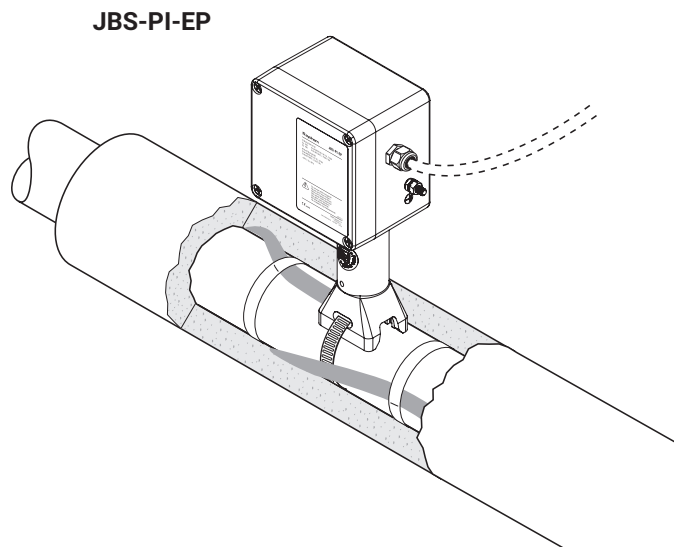

The Raychem JBS-PI-EP kit is designed to connect Raychem XPI industrial series heating cables directly to a power supply without the use of cold leads and with certain power and current restrictions.

The system is approved for hazardous areas and integrates the function of connection kits, cold leads and insulation entry kits. This simplifies the Bill of Materials and actual installation by eliminating the need for special tools or craft sensitive connections.

The XPI heating cables are directly connected into spring-type terminals to provide a fast, reliable and maintenance free operation. This connection system significantly reduces installation time.

The kit is equipped with an earth plate & earth stud to allow for maximum flexibility on the power connection side (metal or polymeric glands)

The design validation depends on cable type, power and temperature and is captured in our design software packages such as TraceCalc Pro.

Application

This kit provides one M25 threaded entry for the power cable. It is also equipped with an integrated earth plate in case metallic power cable glands are used.

The kit can be used with Raychem XPI series heating cables type XPI-(S-)8000 up to XPI-(S-)50 to realize a monophase power connection or a loop end box.

Kit contents

- 1 junction box with spring-type terminals
- 1 stand assembly
- 2 green/yellow earthing sleeves
- 1 skip jumper
- 1 grommet (premounted)
- 1 polywater sachet
- 1 cable tie

PRODUCT SPECIFICATIONS

Dimensions (Nominal)

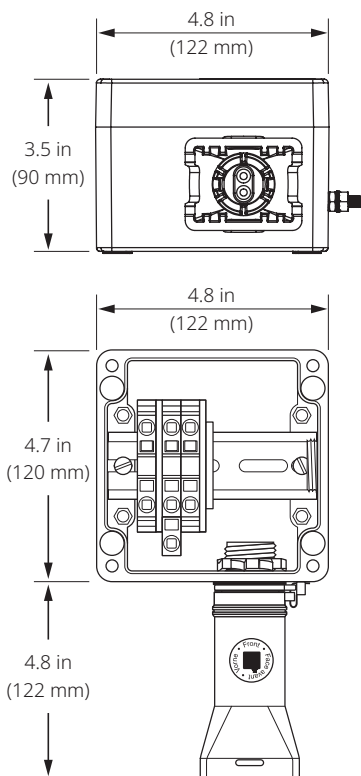

Technical details

Heating cables	XPI-8000 up to XPI-50 XPI-S-8000 up to XPI-S-50 (XPI-F not allowed)
Ingress protection	IP66
Entries	1 x M25
Ambient temperature range	-55°C up to +56°C
Minimum installation temperature	-55°C
Max continuous pipe temperature	160°C*
Terminals	16 mm ² Spring-type terminals (terminal configuration & types cannot be altered w/o consulting Chemelex)
Max conductor size	16 mm ² stranded and solid
Max operating voltage	550 Vac
Max continuous operating current	45 A*
Max start-up current	70 A*
Power cable gland	minimum required rating 90°C (not included)

* Different current and power restrictions apply for different ambient temperatures, pipe temperatures and cable types. Use Chemelex design software packages to validate the usage for your application.

Materials of construction and weight

Enclosure, lid and stand	Electrostatic charge resistant glass-filled engineered polymer (Black)
Lid screws	Stainless steel (captive screws)
Lid gasket	Silicone rubber
Earth continuity plate	Steel, zinc plated and blue chromated
Weight	1.3 kg

APPROVALS

For use in ordinary and hazardous area Zone 1 and Zone 2 (Gas), Zone 21 and Zone 22 (Dust).

Temperature classification

Temperature classification is defined by the complete system.

Product certification



More details about product certification, approvals and conditions of safe use are available in the installation manual at www.chemelex.com.

ORDERING DETAILS

Part description	JBS-PI-EP
PN	P000004428

Accessories

Small pipe adaptor	JBS-SPA, required for pipes ≤ 1 " (DN 25) (bag of 5 adaptors)
--------------------	--

North America

Tel +1 800 545 6258
info@chemelex.com

Latin America

Tel +1 713 868 4800
info@chemelex.com

Europe, Middle East, Africa, India

Tel +32 16 213 511
Fax +32 16 213 604
info@chemelex.com

Asia Pacific

Tel +86 21 2412 1688
infoAPAC@chemelex.com

chemelex
excellence is everything

Raychem Tracer Pyrotenax Nuheat