

## Self-Regulating heating cables for frost heave protection Frost heave protection for cryogenic storage tank foundations

### PRODUCT OVERVIEW

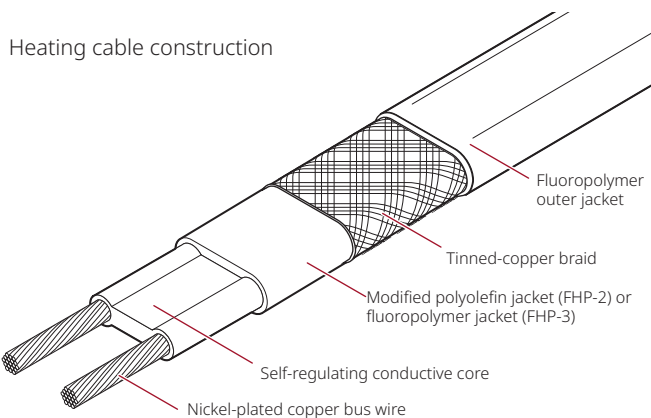

The FHP family of self-regulating heating cables prevents frost heave by maintaining the temperature of cryogenic and low temperature storage tank foundations above freezing.

FHP heating cables are available for all tank sizes and construction. FHP heating cables can be cut to length and terminated in the field.

The FHP heating cables have an unconditional T-rating simplifying design for use in hazardous and nonhazardous areas, including areas where corrosives may be present.

For additional information, contact your Chemelex representative.

### SPECIFICATIONS

	FHP-2	FHP-3
Catalog number	FHP-2	FHP-3
Weight (nominal)	0.15 kg/m (1.0 lb/10 ft)	0.13 kg/m (0.85 lb/10 ft)
Bus wire size	16 AWG (~1.2 mm <sup>2</sup> )	16 AWG (~1.4 mm <sup>2</sup> )
Outer jacket color	Black	Brown
Heating cable dimensions (nominal)	15 mm x 5 mm (0.6 in x 0.2 in)	13 mm x 5 mm (0.5 in x 0.2 in)

### TEMPERATURE RATING

	FHP-2	FHP-3
Maximum maintain temperature or continuous exposure temperature (power on)	65°C (150°F)	110°C (225°F)
Maximum intermittent exposure temperature, 1000 hours (power on or off)	85°C (185°F)	110°C (225°F)
Temperature ID number (T-rating)	T6: 85°C (185°F)	T4: 135°C (275°F)
Voltage	200–277 Vac	200–277 Vac
Maximum circuit length	110 m (360 ft)	110 m (360 ft)
Minimum installation temperature		
Baseefa06ATEX0187X, IECEx BAS 06.0047X	-60°C (-76°F)	-60°C (-76°F)
FM Approved	-40°C (-40°F)	-40°C (-40°F)

### APPROVALS

#### Hazardous Locations



Class I, Div. 1 & 2, Groups B, C, D  
Class II, Div. 1 & 2, Groups E, F, G  
Class III



IECEx BAS 06.0047X  
Ex e IIC T<sup>6</sup> or T<sup>4</sup> Gb  
Ex tD A21 IP66 T80°C or T130°C



Baseefa06ATEX0187X  
II 2 GD Ex e IIC T<sup>6</sup> or T<sup>4</sup> Gb  
Ex tD A21 IP66 T80°C or T130°C

## NOMINAL POWER OUTPUT RATING IN METAL CONDUIT AT 240 VAC

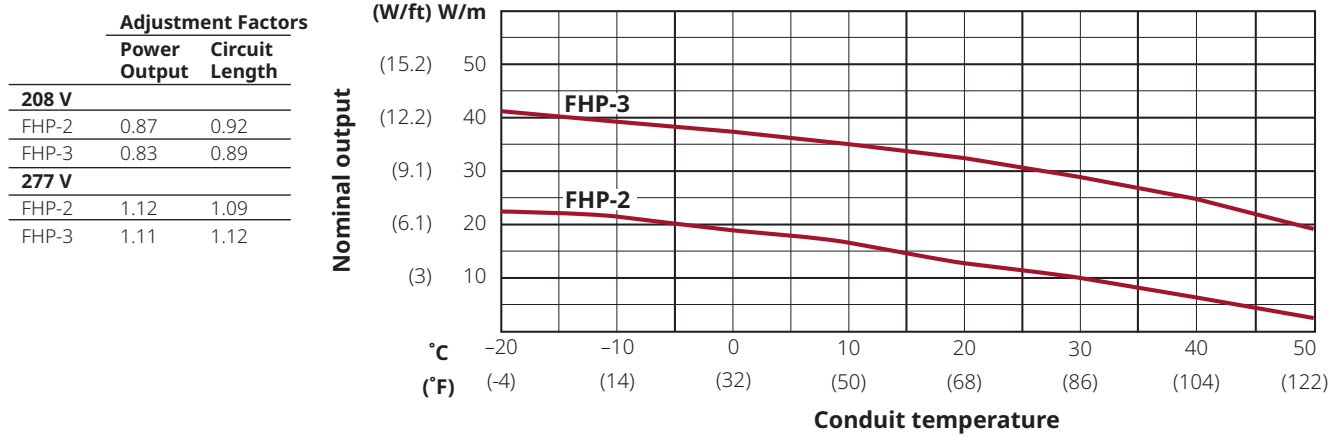

## GROUND-FAULT PROTECTION

A 30-mA residual current device or ground leakage circuit breaker must be used to provide protection from arcing or fire and to comply with Chemelex requirements, agency certifications, and national electrical codes. Where properly installed circuits result in a higher leakage current due to their long length, devices with higher trip currents, to a maximum of 300 mA, may be used. Suitable ground-fault breakers include Square D Type QO-EPD, QOB-EPD and EDB-EPD, and Cutler Hammer (Westinghouse) Type QBGFEF.

## DESIGN AND INSTALLATION

Application must be engineered by Chemelex and use Chemelex connection kits.

## CONNECTION KITS

The connection kits listed below, or Chemelex approved equivalents, must be used to ensure that the FHP system functions properly and complies with warranty, code, and approvals requirements. These connection kits are part of the FHP engineered system and must be selected by Chemelex.

Type	Catalog number	Description	Approvals
Power connection kit	HAK-C-100 and HAK-JB3-100	Explosion-proof multiple-entry power, splice, tee and end termination kit	FM
	JBS-100-E	Single-entry power connection with junction box	Baseefa (ATEX & IECEx)
	JBS-100-EP	Single-entry power connection with junction box with earth plate	Baseefa (ATEX & IECEx)
	JBM-100-E	Multiple-entry power connection with junction box	Baseefa (ATEX & IECEx)
	JBM-100-EP	Multiple-entry power connection with junction box with earth plate	Baseefa (ATEX & IECEx)
	C-150-E	Low profile power connection	Baseefa (ATEX & IECEx)
End seal	FHP-PL-E	End seal kit with pulling lug	Baseefa (ATEX & IECEx)
	E-150	Low profile end seal	Baseefa (ATEX & IECEx)
	E-06	Heat shrink end seal	Baseefa (ATEX & IECEx)

## CONNECTION KITS, CONTINUED

Type	Catalog number	Description	Approvals
Connection kits to be used with junction boxes	C75-100-A	Heating cable gland kit	FM
	C25-21-FHP	Connection kit, M25 (heat shrinkable)	Baseefa (ATEX & IECEx)
	C25-100-FHP	Connection kit, M25 (cold applied)	Baseefa (ATEX & IECEx)
	CCON25-100-FHP	Conduit connection kit, M25 (cold applied)	Baseefa (ATEX & IECEx)
	C25-100-METAL-FHP	Brass connection kit, M25 (cold applied)	Baseefa (ATEX & IECEx)
	C25-100-METAL-NP-FHP	Nickel-plated brass connection kit, M25 (cold applied)	Baseefa (ATEX & IECEx)
	C3/4-100-METAL-FHP	Brass connection kit, 3/4" NPT (cold applied)	Baseefa (ATEX & IECEx)
Junction box	JBU-100-E-FHP	Junction box to be engineered according to constraints mentioned in approval	Baseefa (ATEX & IECEx)
	JBU-100-EP-FHP	Junction box with earth plate to be engineered according to constraints mentioned in approval	Baseefa (ATEX & IECEx)

### North America

Tel +1 800 545 6258  
info@chemelex.com

### Latin America

Tel +1 713 868 4800  
info@chemelex.com

### Europe, Middle East, Africa, India

Tel +32 16 213 511  
Fax +32 16 213 604  
info@chemelex.com

### Asia Pacific

Tel +86 21 2412 1688  
infoAPAC@chemelex.com



**Raychem Tracer Pyrotenax Nuheat**