

Hazardous area, battery powered flashing led alarm signal

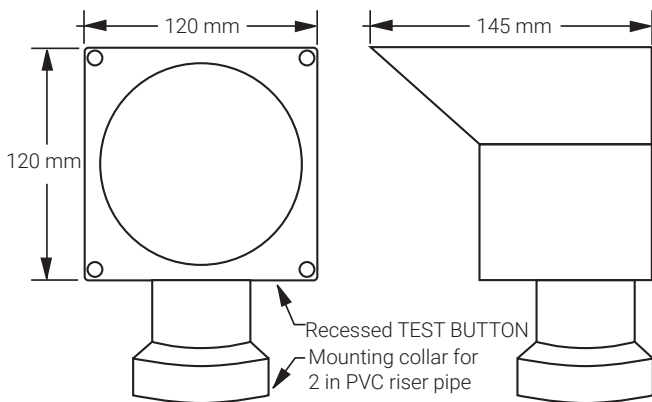

TT-FLASHER-BE with protective rain hood/shadow box for enhanced daylight visibility



PRODUCT OVERVIEW

Simple, effective leak indication

The Raychem TraceTek TT-FLASHER-BE is an inexpensive, battery powered device that provides an easy-to-see flashing light signal whenever a TraceTek sensor cable or probe detects a leak. Because it is completely self contained and requires no external connections, it is simple and inexpensive to install.

Intrinsically safe and rated for hazardous areas

TT-FLASHER-BE operates on two "AA" Alkaline, long-life batteries. Because the available voltage is limited to 3.3 V and because the TraceTek sensor cables and probes require very limited energy, this device is approved as intrinsically safe. The sensor cable, probes, jumper cable and the TT-FLASHER-BE itself can be installed in most hazardous area classifications (see approvals section for details). TT-FLASHER-BE can monitor any of the TraceTek family of sensor cables including Raychem TT3000, TT5000, TT5001 and TT7000. The device will also monitor the Raychem TT-FFS fast acting fuel detection probe. No external zener safety barriers are required; sensor cable or probes are connected directly to the TT-FLASHER-BE.

Visual indication only

TT-FLASHER-BE provides the ultimate in simple operation: A flashing RED light indicates that a leak has been detected. There are no external relay signals and no connections to other alarm systems.

A TEST button is provided so that the battery voltage and integrity of the sensor wiring can be easily verified.

TT-FLASHER-BE will signal a low battery condition with a double-flash signal for about 1 month before the battery voltage drops to an unusable level. However, batteries should be changed as part of an annual preventive maintenance schedule.

Trade off: simplicity vs. human factors

Because TT-FLASHER-BE is designed to be seen by an operator, it is not suitable for all installations. There is no provision for relay contacts or other means of remote alarm indication. The TT-FLASHER-BE must be seen and the local facility staff must respond to the visual signal for the system to be effective. Likewise if the batteries are allowed to go completely dead, the TT-FLASHER-BE will be unable to signal a leak situation.

OPERATION AND INDICATIONS

Normal operation	Normal indication is no flashing light	
Leak detected	Flashing red light (3 high intensity LEDs) Flashing interval at once per second	
Low battery	Double flash at 2 second interval	
Leak detected and low battery	Alternating single and double flash at 1 second interval	
When test button is pushed	Single flash at 1 second interval No flash	Battery voltage is ok and wiring to sensor cable is good. This is the normal "good test" indication Sensor wiring is damaged, sensor is disconnected or battery is completely dead. Immediate servicing is required!*
		* Weekly interval test is recommended

Special Operating Note

The TT-FLASHER-BE must be seen in order to be effective. The TT-FLASHER-BE body is often mounted on a vertical riser pipe and the head should be rotated so that the lens is easily seen by facility personnel from their normal work stations or as they walk or drive by the TT-FLASHER-BE location. When used together with TraceTek sensor cables or probes, the TT-FLASHER-BE is very effective at providing early indications of underground or concealed leaks, but it not effective if it is not seen or if the plant personnel do not report and respond to the flashing leak signal. When TT-FLASHER-BE is first installed in a new facility, the operating staff should be briefed in how the new equipment is intended to operate and what to do if a flashing LEAK signal is detected.

Caution

Do not use TT-FLASHER-BE in a plant safety or emergency shut-down application that requires immediate response. TraceTek offers other monitoring and telemetry solutions for situations that require immediate feedback to the control room.

ORDERING INFORMATION

Catalog number	P/N	Description
TT-FLASHER-BE	P000000837	Battery powered, flashing light, leak detection indicator

PRODUCT CHARACTERISTICS

Maximum length of sensing cable	300m (1000 ft) or 1 TT-FFS
Enclosure rating	NEMA-4X, IP66 anti-static materials
Weight (with rain hood and leader cable)	1.4 kg nominal
Light source	3 high intensity, high efficiency red LEDs
Battery information	2 "AA" Alkaline Long Life Duracell MN 1500
Projected battery life	2 years – nominal
Recommended battery replacement interval	1 year or whenever low battery signal is detected
Duration of leak detected signal	Minimum 30 days at 20°C
Duration of low battery signal	Minimum 30 days at 20°C
Rain/UV resistance	Suitable for outdoor installations
Maximum ambient temperature	40°C
Minimum ambient temperature	-20°C (operational with limited duration to -40°C)

APPROVALS AND CERTIFICATIONS



Intrinsically Safe Apparatus
Class I Div 1 Groups A, B, C & D
AEx ia IIC T4

Baseefa09ATEX0150X IECEx BAS 09.0064X Ex II 1G
Ex ia IIC T4 Ga (-20°C ≤ Ta ≤ +40°C)



Ex ia IIC T4
Enclosure Type: 4X, IP66
Temp Code T4

Entity parameters:
U_s = 3.3V I_s = 7.3mA P_s = 6.02mW C_s = 100µF L_s = 200mH

HAZARDOUS AREA INSTALLATIONS

The TT-FLASHER-BE is approved for use in hazardous areas. The module can monitor intrinsically safe TraceTek sensors located in hazardous locations, as shown below.

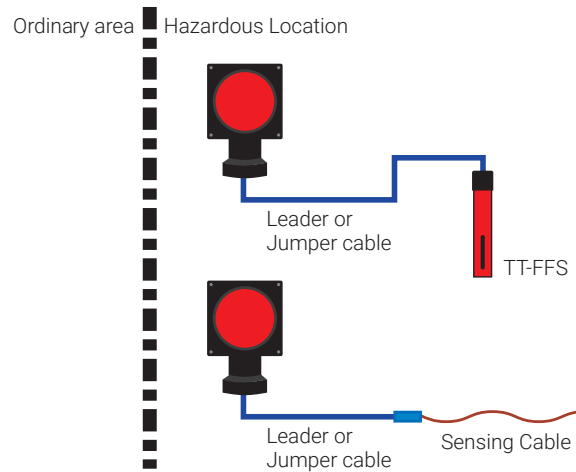

North America

Tel +1 800 545 6258
info@chemelex.com

Latin America

Tel +1 713 868 4800
info@chemelex.com

Europe, Middle East, Africa, India

Tel +32 16 213 511
Fax +32 16 213 604
info@chemelex.com

Asia Pacific

Tel +86 21 2412 1688
infoAPAC@chemelex.com

chemelex
excellence is everything

Raychem Tracer Pyrotenax Nuheat