

## Fuel sensing cable for aboveground leak detection

### PRODUCT OVERVIEW



Raychem TraceTek TT5000-HUV sensing cable detects the presence of liquid hydrocarbon fuels at any point along its length, yet it does not react to the presence of water. Installed with an Raychem TraceTek Sensor Interface Module and Alarm Panel, the cable senses the hydrocarbon liquid, triggers an alarm and pinpoints the location of the leak within one meter.

#### Designed for aboveground leak detection

TT5000-HUV sensing cable is designed for use on aboveground pipe, around pump pads or valves where the cable will be exposed to sunlight and weather during its service life. The sensor cable core is standard an Raychem TT5000 with well documented response times, numerous third party qualifications and years of successful applications. The cable can be purchased in bulk form, cut to length in the field and joined using connector kits, or it can be obtained in standard or custom cut lengths with connectors attached in the factory. The cable is designed to be attached to the bottom of horizontal piping, spiraled around vertical pipe, or placed on flat surfaces below or around pumps and valves and other applications where surface level fuel leaks and spills can be anticipated.

#### Distinctive appearance and ready for refinery, tank farm and terminal applications

TT5000-HUV sensing cable has a matte black rope outer layer with a red tracer stripe. The rope outer layer is fabricated with thousands of individual filaments that add strength and excellent protection from the damaging effects of direct sunlight exposure. Additionally, this rope layer makes the sensor cable resistant to kinks and pliable, yet rugged enough for installation and long service life in pipe applications.

The sensor cable can have connectors wherever necessary; can be branched as needed and in general can be tailored to match the piping network. Circuits up to 1000 meters can be constructed by connecting individual segments. Multiple circuits can be monitored from a single control room location.

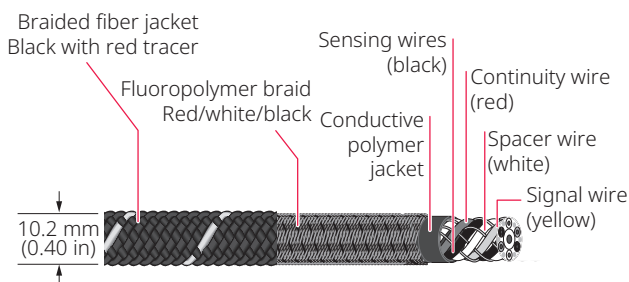

Drawing not to scale  
13 mm (0.52 in)

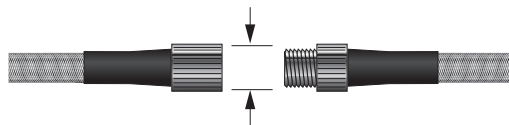

Cable construction

## Advanced technology

Raychem radiation cross-linking and conductive-polymer technology is used to make TT5000-HUV cable. The combination of water and chemically resistant cable core coupled with the enhanced UV protection provided by the rope outer layer yield a product well suited for aboveground leak detection. The cable is able to withstand the rigors of installation and long years of service with exposure to rain, snow, sunlight and similar weather stresses.

## ORDERING INFORMATION

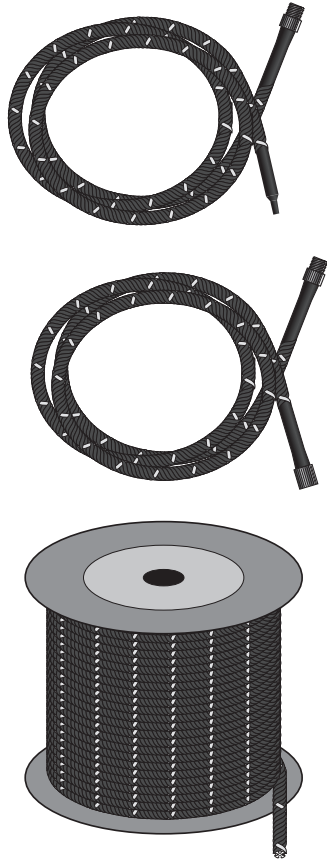

### TT5000-HUV modular sensing cable with factory-installed connectors

Catalog number	Part number	Description
TT5000-HUV-1M-MC	P000001302	1 m (3 ft) sensing cable
TT5000-HUV-3M-MC	P000001301	3 m (10 ft) sensing cable
TT5000-HUV-7.5M-MC	P000001300	7.5 m (25 ft) sensing cable
TT5000-HUV-15M-MC	P000001299	15 m (50 ft) sensing cable
TT5000-HUV-30M-MC	P000001298	30 m (100 ft) sensing cable
TT5000-HUV-50M-MC	P000001297	50 m (164 ft) sensing cable
TT5000-HUV-100M-MC	P000001296	100 m (328 ft) sensing cable

### TT5000-HUV bulk sensing cable (connector kits required)

Catalog number	Part number	Description
TT5000-HUV-SC	P000000821	Bulk sensing cable on reel Minimum length: 30 m (100 ft) Maximum length: 240 m (800 ft)

### Connector kits (not shown)

Catalog number	Part number	Description
TT5000-HUV-CK-MC-M/F (includes test tools)	P000001207	Components for five mated pairs of connectors

### Installation materials

Catalog number	Part number	Description
TT-PU-FOAM-2x0.5	P000001136	2-inch wide foam with adhesive backing
TT-VSTRAP-1.5x75ft	P000001135	Fastening strap

## PRODUCT CHARACTERISTICS

Cable diameter	7 mm (0.28 in) nominal
Cable diameter with connector	13 mm (0.52 in) nominal
Cable diameter with rope braid	10.2 mm (0.40 in) nominal
Fluoropolymer braid	Color—red, white and black
Braided fiber jacket	Color—black with red tracer
Cable weight	8.8 kg/100 m nominal (5.9 lb/100 ft nominal)
Operating temperature range	-20°C to 60°C (-4°F to 140°F)
Pull force limit	Not to exceed 100 kg (220 lb)
Bend radius	50 mm (2 in) minimum
Pressure	Loads greater than 9 kg (20 lb) per linear inch at 20°C (68°F) may immediately trigger an alarm
Nonresettable	Must be replaced after exposure to most hydrocarbon liquids

## CHEMICAL RESISTANCE

Cable functions normally after exposure in accordance with ASTM D 543 at 23°C (73°F) for seven days	Sulfuric acid	(10%)
	Hydrochloric acid	(10%)
	Nitric acid	(10%)
	Sodium hydroxide	(10%)

## WATER RESISTANCE

Sensing cable	Less than 10 µA leakage when immersed in salt water for 90 days
Connector system	Less than 10 µA leakage when immersed in water at 10 psig for 24 hours

## RESPONSE TIME

Represented materials detected	Typical response time at 20°C (68°F)
Gasoline	12 minutes
#1 diesel fuel	60 minutes
#2 diesel fuel	120 minutes
JP5 jet fuel	70 minutes
JP8 jet fuel	50 minutes
Jet-A jet fuel	50 minutes
MTBE (Methyl Tert-Butyl Ether)	45 minutes
Xylene	20 minutes

### Notes:

- Response Time Test Method: "Test Procedures for Third Party Evaluation of Leak Detection Methods; Cable Sensor Liquid Contact Leak Detection Systems."
- Response times are affected by operating temperature. Consult factory for specific response times at other temperatures and in other liquids.

## APPROVALS AND CERTIFICATIONS

TT5000-HUV sensing cables are approved for installation in ordinary and hazardous areas when used in conjunction with approved Raychem TraceTek monitoring equipment and zener safety barriers when appropriate.

All Raychem TraceTek sensing cables are designated as "simple apparatus" and included in the approval certification for Raychem TraceTek monitoring instruments.

Consult the specific data sheets and approval certificates for Raychem TraceTek monitoring instruments for application limitations and specific area approvals and certifications



The TT5000-HUV sensing cable is FM approved in the TraceTek Leak Detection System that detects the presence of liquid hydrogen fuels when installed with a TraceTek Alarm and Locator Module.

### North America

Tel +1 800 545 6258  
info@chemelex.com

### Latin America

Tel +1 713 868 4800  
info@chemelex.com

### Europe, Middle East, Africa, India

Tel +32 16 213 511  
Fax +32 16 213 604  
info@chemelex.com

### Asia Pacific

Tel +86 21 2412 1688  
infoAPAC@chemelex.com

**chemelex**  
excellence is everything

**Raychem Tracer Pyrotenax Nuheat**