

Pipe Freeze Protection and Flow Maintenance — XL-Trace Edge System



This step-by-step design guide provides the tools necessary to design a Raychem XL-Trace Edge pipe freeze protection or flow maintenance system. For other applications or for design assistance, contact your Raychem representative or call (800) 545-6258. Also, visit our website at chemelex.com.

Table of Contents

INTRODUCTION	1
How to Use this Guide.....	2
Safety Guidelines.....	2
Warranty.....	3
SYSTEM OVERVIEW	3
XL-Trace Edge Applications.....	3
Self-Regulating Heating Cable Construction.....	4
PIPE FREEZE PROTECTION APPLICATIONS	5
Typical Pipe Freeze Protection System.....	5
General Water Piping.....	6
FLOW MAINTENANCE APPLICATIONS.....	8
Typical Flow Maintenance System.....	8
Grease Waste Lines	9
Fuel Lines.....	11
PIPE FREEZE PROTECTION AND FLOW MAINTENANCE DESIGN.....	12
Design Step by Step.....	12
Step 1 Determine design conditions and pipe heat loss.....	12
Step 2 Select the heating cable.....	17
Step 3 Determine the heating cable length.....	20
Step 4 Determine the electrical parameters.....	22
Step 5 Select the connection kits and accessories.....	26
Step 6 Select the control system.....	31
Step 7 Select the power distribution.....	33
Step 8 Complete the Bill of Materials.....	35
XL-TRACE EDGE SYSTEM PIPE FREEZE PROTECTION AND FLOW MAINTENANCE DESIGN WORKSHEET	36

INTRODUCTION

This design guide presents Raychem ' recommendation for designing an XL-Trace Edge pipe freeze protection and flow maintenance system for the following applications:

- Freeze protection of general water piping (above ground and buried)
- Flow maintenance of waste lines (above ground and buried)
- Flow maintenance of fuel lines (above ground)

This guide does **not** cover applications in which any of the following conditions exist:

- Hazardous locations, as defined in the national electrical codes
- Pipe temperature other than specified in Table 1 on page 3
- Pipe maintenance temperatures above 150°F (65°C)
- Supply voltage other than 120 V or 208–277 V



For designing XL-Trace Edge pipe freeze protection system for fire sprinkler piping, please refer to the XL-Trace Edge System for Fire Sprinkler Freeze Protection Design Guide (H58489).

If your application conditions are different, or if you have any questions, contact your Raychem representative or call (800) 545-6258.

How to Use this Guide

This design guide presents Raychem recommendations for designing an XL-Trace Edge pipe freeze protection or flow maintenance system. It provides design and performance data, electrical sizing information, and application configuration suggestions. Following these recommendations will result in a reliable, energy-efficient system.

Other Required Documents

This guide is not intended to provide comprehensive installation instructions. For complete XL-Trace Edge pipe freeze protection and flow maintenance system installation instructions, please refer to the following additional required documents:

- XL-Trace Edge System Installation and Operation Manual (H58033)
- Additional installation instructions are included with the connection kits, thermostats, controllers, and accessories

If you do not have these documents, you can obtain them from our website at chemelex.com.

For products and applications not covered by this design guide, please contact your Raychem representative or call (800) 545-6258.

Safety Guidelines

As with any electrical equipment, the safety and reliability of any system depends on the quality of the products selected and the manner in which they are installed and maintained. Incorrect design, handling, installation, or maintenance of any of the system connection kits could damage the system and may result in inadequate performance, overheating, electric shock, or fire. To minimize these risks and to ensure that the system performs reliably, read and carefully follow the information, warnings, and instructions in this guide.



This symbol identifies important instructions or information.



This symbol identifies particularly important safety warnings that must be followed.



WARNING: To minimize the danger of fire from sustained electrical arcing if the heating cable is damaged or improperly installed, and to comply with the requirements of Raychem, agency certifications, and national electrical codes, ground fault equipment protection must be used on each heating cable branch circuit. Arcing may not be stopped by conventional circuit protection.

Warranty



Raychem standard limited warranty applies to all products.

An extension of the limited warranty period to ten (10) years from the date of installation is available if a properly completed online warranty form is submitted within thirty (30) days from the date of installation. You can access the complete warranty on our website at chemelex.com

Approvals

c-UL-us Listed and c-CSA-us Certified for nonhazardous locations.



3XLE1-CR 5XLE1-CR, -CT 8XLE1-CR, -CT 12XLE2-CR, -CT
3XLE2-CR 5XLE2-CR, -CT 8XLE2-CR, -CT
460 controller



C910-485, ACS-CRM or
ACS-CRMS controllers

SYSTEM OVERVIEW

The XL-Trace Edge system provides freeze protection and flow maintenance for aboveground and buried pipe applications. The XL-Trace Edge system is based on self-regulating heating cable technology. Raychem offers four self-regulating heating cables with the XL-Trace Edge system: 3XLE, 5XLE, 8XLE, and 12XLE (208–277 V only) for applications using 120 V and 208–277 V power supplies. All cables' output is reduced automatically as the pipe warms, so there is no possibility of failure due to overheating.

An XL-Trace Edge system includes the heating cable, power connection, splice, tee connections, controls, contactors, power distribution panels, accessories, and the tools necessary for a complete installation.

XL-Trace Edge Applications

Identify which of the standard XL-Trace Edge applications below pertain to your installation. Proceed to the appropriate design sections that follow.

Table 1 XL-Trace Edge Applications

Application	Description	Specific application requirements
Pipe freeze protection		
General water piping	Freeze protection (40°F [4°C] minimum) of insulated, metal or plastic water piping	"Aboveground piping" on page 9 "Buried piping," page 10
Flow maintenance		
Grease waste lines	Flow maintenance (110°F [43°C] minimum) for insulated grease waste lines	"Aboveground piping" on page 9 "Buried piping," page 10
Fuel lines	Flow maintenance (40°F [4°C] minimum) for insulated metal piping containing #2 fuel oil	"For aboveground piping only," on page 11

Note: If your application does not fit these guidelines, contact your local Raychem representative or call (800) 545-6258.

Self-Regulating Heating Cable Construction

XL-Trace Edge self-regulating heating cables are comprised of two parallel nickel-plated bus wires in a cross-linked polymer core, a tinned copper braid, and a fluoropolymer or polyolefin outer jacket. These cables are cut to length, simplifying the application design and installation.

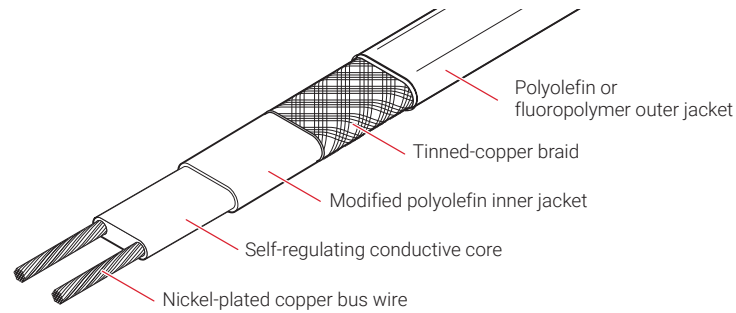

Fig. 1 XL-Trace Edge heating cable construction

With self-regulating technology, the number of electrical paths between bus wires changes in response to temperature fluctuations. As the temperature surrounding the heater decreases, the conductive core contracts microscopically. This contraction decreases electrical resistance and creates numerous electrical paths between the bus wires. Current flows across these paths to warm the core.

As the temperature rises, the core expands microscopically. This expansion increases electrical resistance and the number of electrical paths decreases. The heating cable automatically reduces its output.

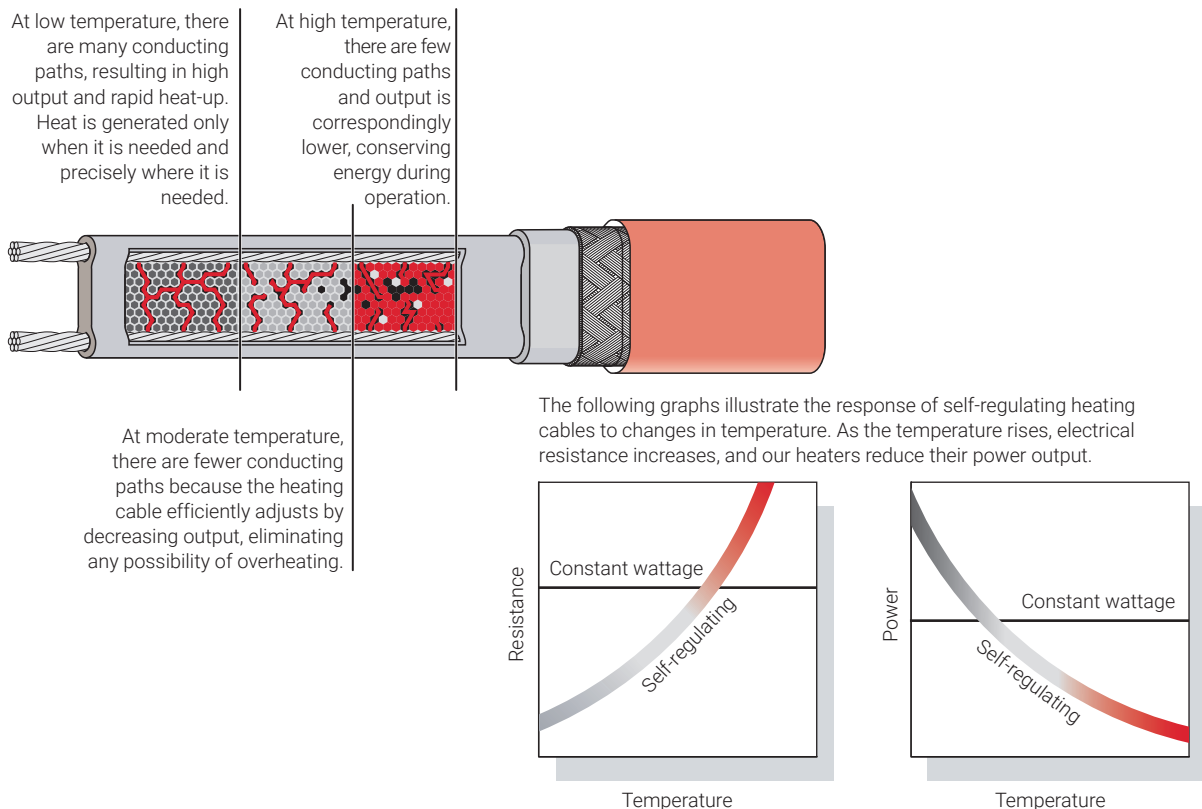

Fig. 2 Self-regulating heating cable technology

PIPE FREEZE PROTECTION APPLICATIONS

A pipe freeze protection system is designed to maintain the pipe temperature at a minimum of 40°F (4°C) to prevent freezing.

Typical Pipe Freeze Protection System

A typical pipe freeze protection system includes the XL-Trace Edge self-regulating heating cables, connection kits, ambient temperature control, and power distribution.

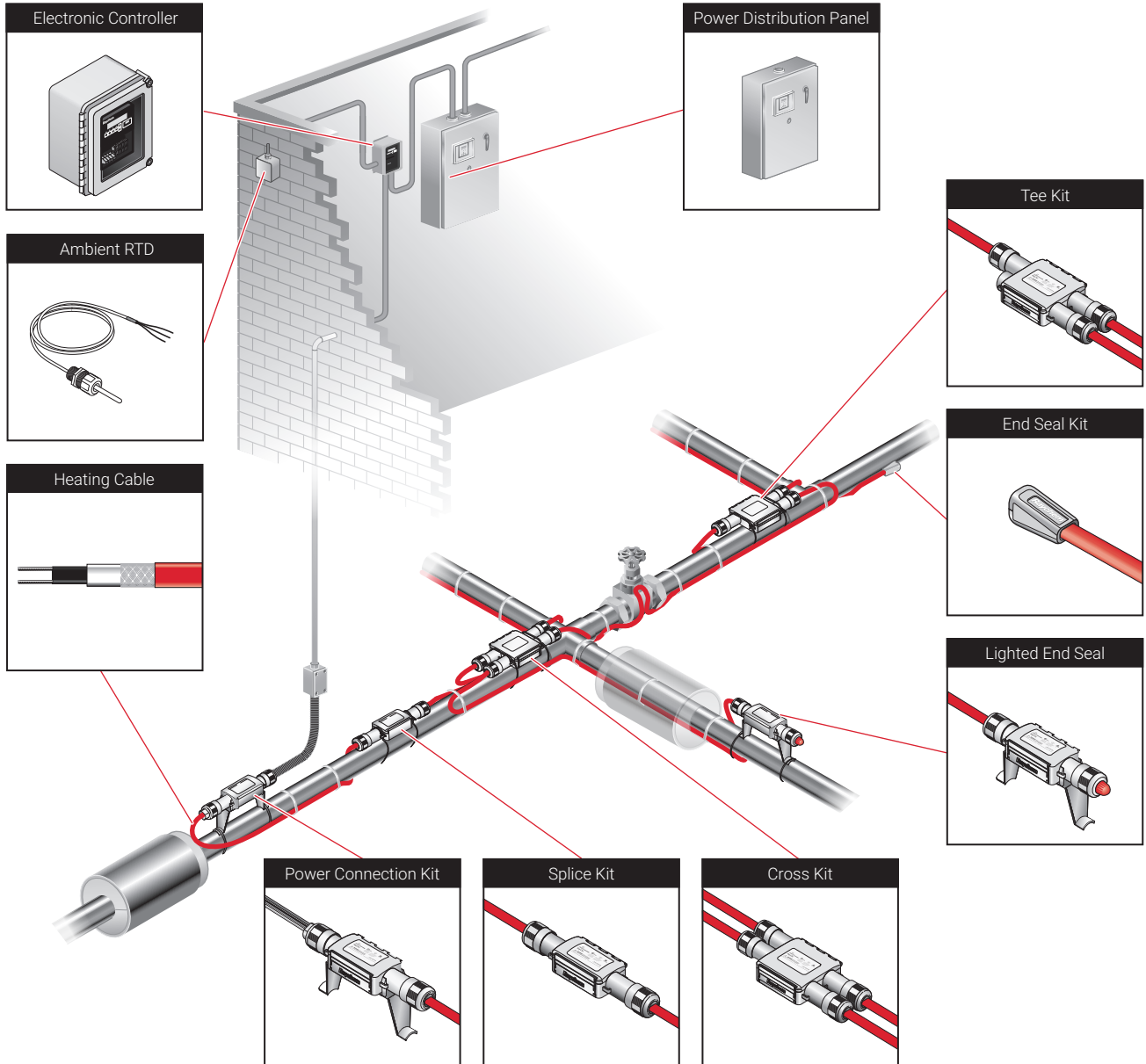

Fig. 3 Typical XL-Trace Edge pipe freeze protection system

General Water Piping

General water piping is defined as metal or plastic water piping located in nonhazardous locations.

ABOVEGROUND PIPING

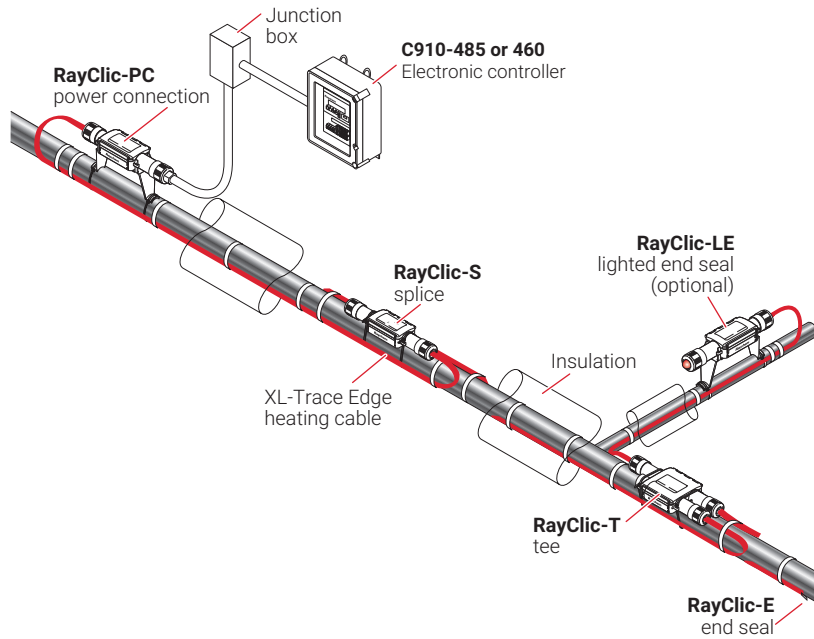

Fig. 4 Typical aboveground piping system

Application Requirements

The system complies with Raychem requirements for aboveground general water piping when:

- The heating cable is permanently secured to insulated metal pipes with GT-66 glass tape, or to plastic pipes using AT-180 aluminum tape.
- A 30-mA ground fault protection device (GFPD) is used.
- The heating cable is installed per manufacturer's instructions with approved Raychem connection kits. See Table 13 on page 27 and the XL-Trace Edge System Installation and Operation Manual (H58033).

Cable Selection

See "Other Required Documents" page 2.

Buried Piping

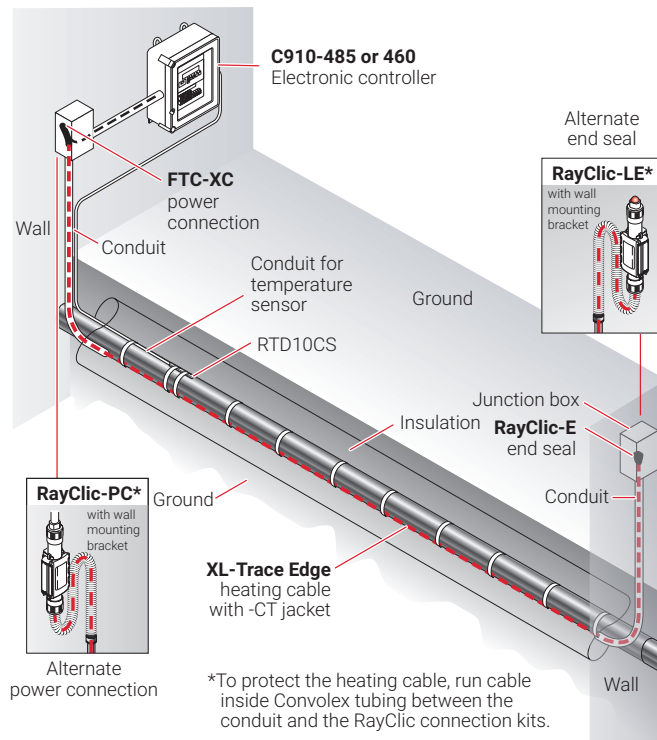

Fig. 5 Typical buried piping system

Application Requirements

The system complies with Raychem requirements for use on buried insulated metal or plastic pipe when:

- The heating cable is permanently secured to metal pipes with GT-66 glass tape or to plastic pipes using AT-180 aluminum tape.
- The pipeline is buried at least 2-feet deep.
- All heating cable connections (power, splice, tee, and end termination) are made above-ground. No buried or in-conduit splices or tees are allowed.
- The heating cable has a fluoropolymer outer jacket (-CT).
- The power connection and end seal are made in UL Listed and CSA Certified junction boxes above grade.
- The heating cable is protected from the pipe to the power connection box in UL Listed and CSA Certified water-sealed conduit (minimum 3/4-inch diameter) suitable for the location.
- A 30-mA ground fault protection device (GFPD) is used.
- Closed-cell, waterproof thermal insulation with fire-retardant, waterproof covering is used.
- The heating cable is installed per manufacturer's instructions with approved Raychem connection kits. See Table 15 on page 29 and the XL-Trace Edge System Installation and Operation Manual (H58033).

Cable Selection

See "Pipe Heat Loss Calculations" page 13.

A flow maintenance system is designed to maintain cooking grease waste lines and #2 fuel oil lines above the temperature at which the viscosity inhibits fluid flow.

Typical Flow Maintenance System

A typical flow maintenance system includes the XL-Trace Edge self-regulating heating cables with a fluoropolymer outer jacket, connection kits, line-sensing temperature control and power distribution.

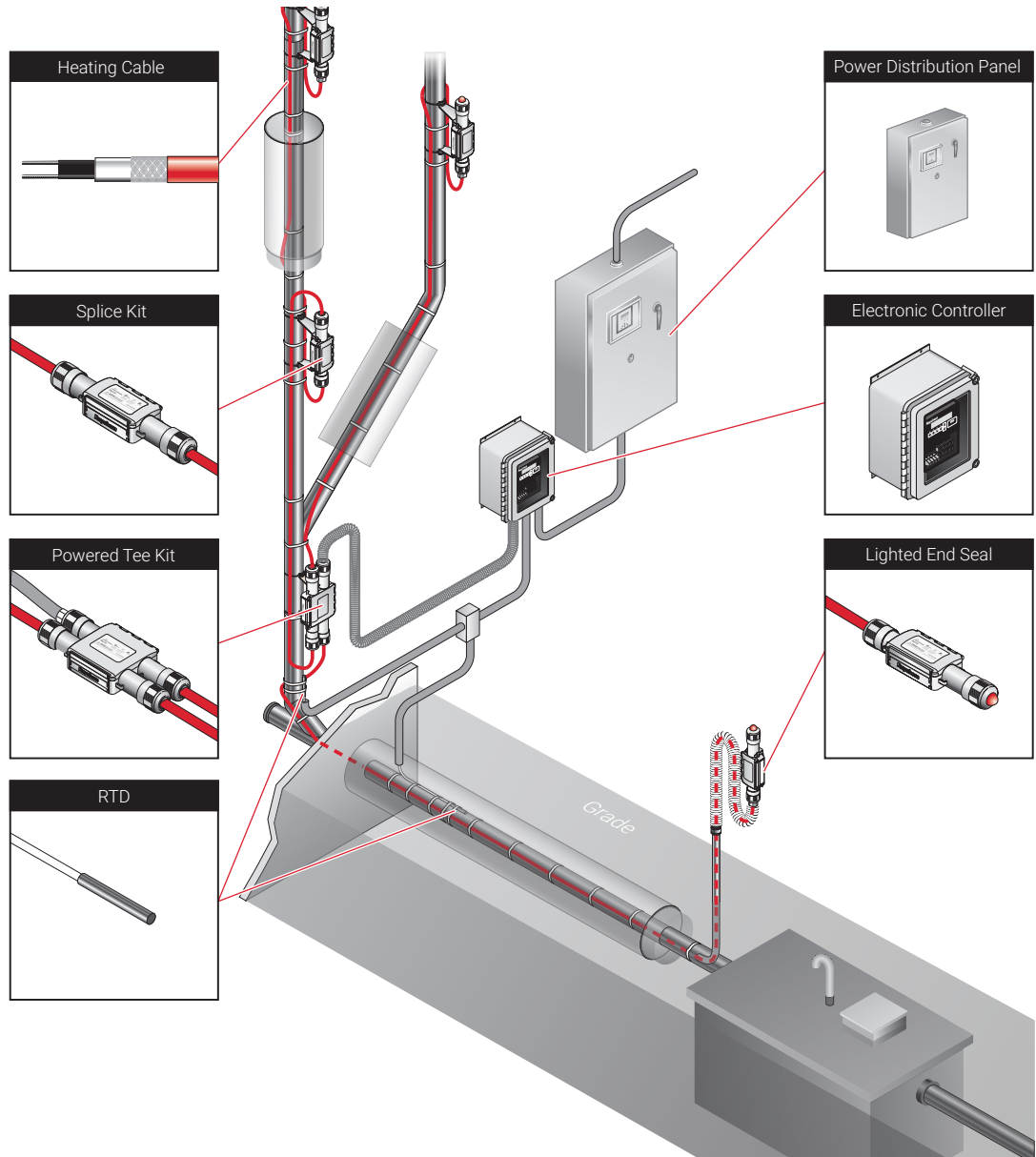

Fig. 6 Typical XL-Trace Edge flow maintenance system

Grease Waste Lines

Grease waste lines are defined as piping used for the disposal of waste oils and fats created in the cooking process. Typical applications include grease waste lines from commercial restaurants. A grease-line flow maintenance system is designed to maintain a 110°F (43°C) minimum fluid temperature.

Above Ground piping

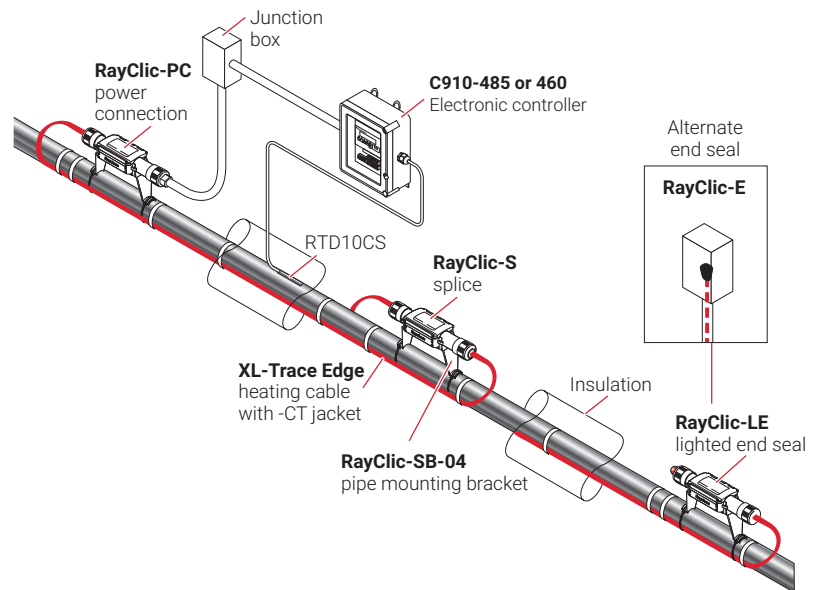

Fig. 7 Typical aboveground piping system

Application Requirements

The system complies with Raychem requirements for aboveground grease waste lines when:

- The heating cable is permanently secured to metal pipes with GT-66 glass tape, or to plastic pipes using AT-180 aluminum tape.
- The heating cable must have a fluoropolymer outer jacket (-CT).
- A 30-mA ground fault protection device (GFPD) is used.
- Tees and splices are installed using pipe mounting brackets, not in direct contact with piping.
- The heating cable is installed per manufacturer's instructions with approved Raychem connection kits. See Table 13 on page 27 and the XL-Trace Edge System Installation and Operation Manual (H58033).

Cable Selection

See "Pipe Heat Loss Calculations" page 13.

Buried Piping

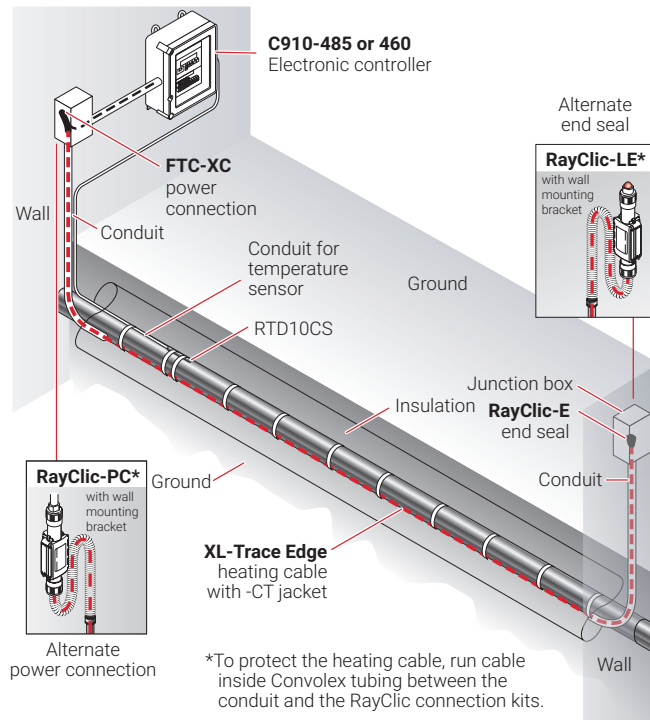

Fig. 8 Typical buried grease waste line

Application Requirements

The system complies with Raychem requirements for buried grease waste lines when:

- The heating cable is permanently secured to metal pipes with GT-66 glass tape, or to plastic pipes using AT-180 aluminum tape.
- The heating cable must have a fluoropolymer outer jacket (-CT).
- The pipeline is buried at least 2-feet deep.
- All heating cable splices or tees are made aboveground. No buried or in-conduit splices or tees are allowed.
- The power connection and end seal are made in UL Listed and CSA Certified junction boxes above grade.
- The heating cable is protected from the pipe to the power connection box in UL Listed and CSA Certified conduit (minimum 3/4-inch diameter) suitable for the location.
- A 30-mA ground fault protection device (GFPD) is used.
- Closed-cell, waterproof thermal insulation with fire-retardant, waterproof covering is used.
- The heating cable is installed per manufacturer's instructions with approved Raychem connection kits. See Table 15 on page 29 and the XL-Trace Edge System Installation and Operation Manual (H58033).

Cable Selection

See "Heating Cable Catalog Number" on page 17.

Fuel Lines

Fuel lines are defined as those carrying #2 fuel oil. A fuel line flow maintenance system is designed to maintain a 40°F (4°C) minimum fluid temperature to maintain flow.

FOR ABOVEGROUND PIPING ONLY

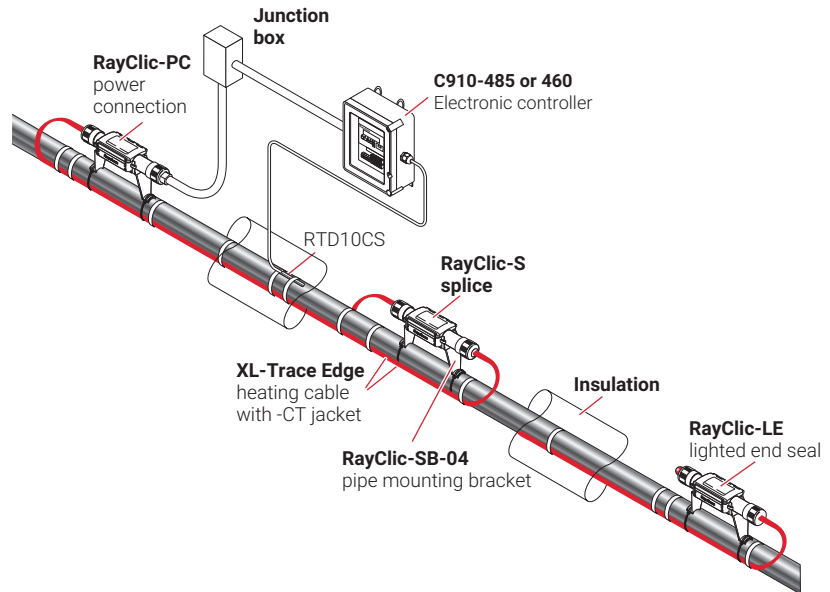

Fig. 9 Typical aboveground piping system

Application Requirements

The system complies with Raychem requirements for aboveground #2 fuel oil piping when:

- The heating cable is permanently secured to metal pipes with GT-66 glass tape or to plastic pipes using AT-180 aluminum tape.
- The heating cable must have a fluoropolymer outer jacket (-CT).
- Tees and splices are installed using pipe mounting brackets, not in direct contact with piping.
- A 30-mA ground fault protection device (GFPD) is used.
- The heating cable is installed per manufacturer's instructions with approved Raychem connection kits. See Table 13 on page 27 and the XL-Trace Edge System Installation and Operation Manual (H58033).

Cable Selection

See "Pipe Heat Loss Calculations" page 13.

This section details the design steps necessary to design your application. The examples provided in each step are intended to incrementally illustrate the project parameter output for two sample designs from start to finish. As you go through each step, use the "XL-Trace Edge System Pipe Freeze Protection and Flow Maintenance Design Worksheet" page 36, to document your project parameters, so that by the end of this section you will have the information you need for your Bill of Materials.



TraceCalc Pro for Buildings is an online design tool available to help you create simple or complex heat-tracing designs for pipe freeze protection or flow maintenance applications. It is available at chemelex.com.

Design Step by Step

Your system design requires the following essential steps.

- 1 Determine design conditions and pipe heat loss
- 2 Select the heating cable
- 3 Determine the heating cable length
- 4 Determine the electrical parameters
- 5 Select the connection kits and accessories
- 6 Select the control system
- 7 Select the power distribution
- 8 Complete the Bill of Materials

Pipe Freeze Protection and Flow Maintenance
1. Determine design conditions and pipe heat loss
2. Select the heating cable
3. Determine the heating cable length
4. Determine the electrical parameters
5. Select the connection kits and accessories
6. Select the control system
7. Select the power distribution
8. Complete the Bill of Materials

Step 1 Determine design conditions and pipe heat loss

Collect the following information to determine your design conditions:

- XL-Trace Edge application (from Table 1)
- Location
 - Indoors
 - Outdoors
 - Aboveground
 - Buried
- Maintain temperature (T_M)
- Maximum system temperature (T_{MAX})
- Minimum ambient temperature (T_A)
- Pipe diameter and material
- Pipe length
- Thermal insulation type and thickness
- Supply voltage

Example: Pipe Freeze Protection – Water Piping

Location	Aboveground, outdoor
Maintain temperature (T_M)	40°F (4°C)
Maximum system temperature (T_{MAX})	80°F (27°C)
Minimum ambient temperature (T_A)	-20°F (-29°C)
Pipe diameter and material	2-inch plastic
Pipe length	300 ft (91 m)
Thermal insulation type and thickness	1-inch fiberglass
Supply voltage	120 V

Example: Pipe Freeze Protection – Grease Waste Line

Location	Buried
Maintain temperature (T_M)	110°F (43°C)
Maximum system temperature (T_{MAX})	125°F (52°C)
Minimum ambient temperature (T_A)	50°F (10°C) (soil temperature)
Pipe diameter and material	4-inch metal
Pipe length	200 ft (61 m)
Thermal insulation type and thickness	1-inch rigid cellular urethane
Supply voltage	208 V

Pipe Heat Loss Calculations

To select the proper heating cable you must first determine the pipe heat loss. To do this you must first calculate the temperature differential (ΔT) between the pipe maintain temperature and the minimum ambient temperature.

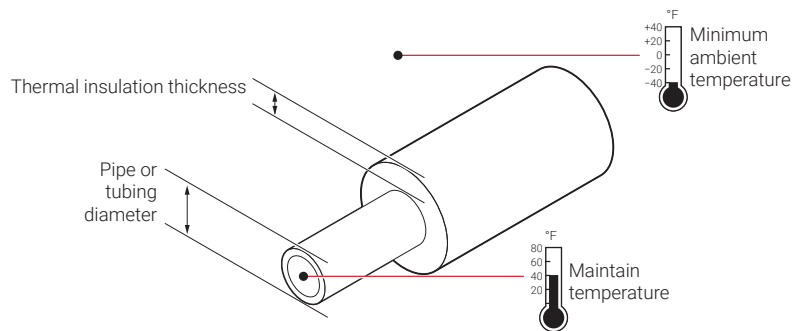

Fig. 10 Pipe heat loss

Calculate temperature differential ΔT

To calculate the temperature differential (ΔT), use the formula below:

$$\Delta T = T_M - T_A$$

Example: Pipe Freeze Protection – Water Piping

T_M	40°F (4°C)
T_A	-20°F (-29°C)
	$\Delta T = 40^\circ\text{F} - (-20^\circ\text{F}) = 60^\circ\text{F}$
	$\Delta T = 4^\circ\text{C} - (-29^\circ\text{C}) = 33^\circ\text{C}$

Example: Flow Maintenance – Grease Waste Line

T_M	110°F (43°C)
T_A	50°F (10°C)
	$\Delta T = 110^\circ\text{F} - (50^\circ\text{F}) = 60^\circ\text{F}$
	$\Delta T = 43^\circ\text{C} - (10^\circ\text{C}) = 33^\circ\text{C}$

Determine the pipe heat loss

Match the pipe size, insulation thickness, and temperature differential (ΔT) from Table 2 to determine the base heat loss of the pipe (Q_B).

Example: Pipe Freeze Protection – Water Piping

Pipe diameter 2 inch
Insulation thickness 1 inch
 ΔT 60°F (33°C)

Heat loss (Q_b) for 60°F must be calculated through interpolation between ΔT at 50°F and ΔT at 100°F from Table 2. For difference between the ΔT of 50°F and the ΔT of 100°F:

Q_{B-50} 3.2 W/ft (from Table 2)

Q_{B-100} 6.8 W/ft (from Table 2)

ΔT interpolation ΔT 60°F is 20% of the distance between ΔT 50°F and ΔT 100°F

$Q_{B-60} = Q_{B-50} + [0.20 \times (Q_{B-100} - Q_{B-50})] = 3.2 + [0.20 \times (6.8 - 3.2)] = 3.9 \text{ W/ft}$

Pipe heat loss (Q_b) **3.9 W/ft @ T_m 40°F (12.9 W/m @ T_m 4°C)**

Example: Flow Maintenance – Grease Waste Line

Pipe diameter 4 inch
Insulation thickness 1 inch
 ΔT 60°F (33°C)

Q_b for 60°F must be calculated through interpolation between ΔT at 50°F and ΔT at 100°F from Table 2. For difference between the ΔT of 50°F and the ΔT of 100°F:

Q_{B-50} 5.4 W/ft (from Table 2)

Q_{B-100} 11.2 W/ft (from Table 2)

ΔT interpolation ΔT 60°F is 20% of the distance between ΔT 50°F and ΔT 100°F

$Q_{B-60} = Q_{B-50} + [0.20 \times (Q_{B-100} - Q_{B-50})] = 5.4 + [0.20 \times (11.2 - 5.4)] = 6.6 \text{ W/ft}$

Pipe heat loss Q_b **6.6 W/ft @ T_m 110°F (21.5 W/m @ T_m 43°C)**

Compensate for insulation type and pipe location

The base heat loss is calculated for a pipe insulated with thermal insulation with a k-factor ranging from 0.2 to 0.3 BTU/hr-°F-ft²/in (fiberglass or foamed elastomer) in an outdoor, or buried application. To get the heat loss for pipes insulated with alternate types of thermal insulation and for pipes installed indoors, multiply the base heat loss of the pipe (Q_b) from Step 3 by the insulation multiple from Table 4 and the indoor multiple from Table 3 to get the corrected heat loss:

$$Q_{\text{CORRECTED}} = Q_b \times \text{Insulation multiple} \times \text{Indoor multiple}$$

Example: Pipe Freeze Protection – Water Piping

Location Aboveground, outdoor
Thermal insulation thickness and type 1-inch fiberglass
Pipe heat loss Q_b 3.9 W/ft @ T_m 40°F (12.9 W/m @ T_m 4°C)
 $Q_{\text{CORRECTED}} = 3.9 \text{ W/ft} \times 1.00 \times 1.00 = 3.9 \text{ W/ft @ T}_m \text{ 40°F}$
(12.9 W/m @ T_m 4°C)

Example: Flow Maintenance – Grease Waste Line

Location Buried
Thermal insulation type and thickness 1-inch rigid cellular urethane
Pipe heat loss $Q_b = 6.6 \text{ W/ft @ T}_m \text{ 110°F (21.5 W/m @ T}_m \text{ 43°C)}$
 $Q_{\text{CORRECTED}} = 6.6 \text{ W/ft} \times 0.6 \times 1.00 = 4.0 \text{ W/ft @ T}_m \text{ 110°F}$
(13.1 W/m @ T_m 43°C)

Table 2 Pipe Heat Loss (Q_B) for Outdoor or Buried Pipe (W/ft) for 1/2 to 3-1/2 inches

Insulation thickness (in)	(ΔT)		Pipe diameter (IPS) in inches								
	°F	°C	1/2	3/4	1	1-1/4	1-1/2	2	2-1/2	3	3-1/2
0.5	20	11	1.0	1.2	1.4	1.6	1.8	2.2	2.5	3.0	3.4
	50	28	2.5	2.9	3.5	4.1	4.6	5.5	6.5	7.7	8.6
	100	56	5.2	6.1	7.2	8.6	9.6	11.5	13.5	16.0	18.0
	150	83	8.1	9.5	11.2	13.4	14.9	17.9	21.1	25.0	28.1
1.0	20	11	0.6	0.7	0.8	1.0	1.1	1.3	1.5	1.7	1.9
	50	28	1.6	1.9	2.2	2.5	2.8	3.2	3.8	4.4	4.9
	100	56	3.4	3.9	4.5	5.2	5.8	6.8	7.8	9.1	10.2
	150	83	5.3	6.1	7.0	8.2	9.0	10.6	12.2	14.2	15.9
1.5	20	11	0.5	0.6	0.7	0.8	0.8	1.0	1.1	1.3	1.4
	50	28	1.3	1.5	1.7	1.9	2.1	2.4	2.8	3.2	3.6
	100	56	2.8	3.1	3.5	4.0	4.4	5.1	5.8	6.7	7.4
	150	83	4.3	4.8	5.5	6.3	6.9	8.0	9.1	10.5	11.6
2.0	20	11	0.5	0.5	0.6	0.6	0.7	0.8	0.9	1.0	1.1
	50	28	1.1	1.3	1.4	1.6	1.8	2.0	2.3	2.6	2.9
	100	56	2.4	2.7	3.0	3.4	3.7	4.2	4.8	5.5	6.0
	150	83	3.7	4.2	4.7	5.3	5.8	6.6	7.5	8.5	9.4
2.5	20	11	0.4	0.5	0.5	0.6	0.6	0.7	0.8	0.9	1.0
	50	28	1.0	1.2	1.3	1.4	1.6	1.8	2.0	2.3	2.5
	100	56	2.2	2.4	2.7	3.0	3.3	3.7	4.2	4.7	5.2
	150	83	3.4	3.7	4.2	4.7	5.1	5.8	6.5	7.4	8.1
3.0	20	11	0.4	0.4	0.5	0.5	0.6	0.6	0.7	0.8	0.9
	50	28	1.0	1.1	1.2	1.3	1.4	1.6	1.8	2.0	2.2
	100	56	2.0	2.2	2.4	2.7	2.9	3.3	3.7	4.2	4.6
	150	83	3.1	3.4	3.8	4.3	4.6	5.2	5.8	6.6	7.1
4.0	20	11	0.3	0.4	0.4	0.5	0.5	0.5	0.6	0.7	0.7
	50	28	0.9	0.9	1.0	1.1	1.2	1.4	1.5	1.7	1.8
	100	56	1.8	2.0	2.1	2.4	2.5	2.9	3.2	3.5	3.8
	150	83	2.8	3.0	3.4	3.7	4.0	4.4	4.9	5.5	6.0

Note: Multiply the W/ft heat loss values by 3.28 for W/m.

Table 2 Continued Pipe Heat Loss (Q_b) for Outdoor or Buried Pipe (W/ft) for 4 to 20 inches

Insulation thickness (in)	(ΔT)		Pipe diameter (IPS) in inches								
	°F	°C	4	6	8	10	12	14	16	18	20
0.5	20	11	3.8	5.3	6.8	8.4	9.9	10.8	12.2	13.7	15.2
	50	28	9.6	13.6	17.4	21.4	25.2	27.5	31.3	35.0	38.8
	100	56	20.0	28.4	36.3	44.6	52.5	57.4	65.2	73.0	80.8
	150	83	31.2	44.3	56.6	69.6	81.9	89.5	101.7	113.8	126.0
1.0	20	11	2.1	2.9	3.7	4.5	5.3	5.8	6.5	7.3	8.0
	50	28	5.4	7.5	9.4	11.5	13.5	14.7	16.6	18.6	20.5
	100	56	11.2	15.6	19.7	24.0	28.1	30.6	34.7	38.7	42.8
	150	83	17.5	24.3	30.7	37.4	43.8	47.8	54.1	60.4	66.7
1.5	20	11	1.5	2.1	2.6	3.2	3.7	4.0	4.5	5.0	5.5
	50	28	3.9	5.3	6.7	8.1	9.4	10.2	11.5	12.9	14.2
	100	56	8.1	11.1	13.9	16.8	19.6	21.3	24.0	26.8	29.5
	150	83	12.7	17.3	21.6	26.2	30.5	33.2	37.5	41.8	46.1
2.0	20	11	1.2	1.7	2.1	2.5	2.9	3.1	3.5	3.9	4.3
	50	28	3.1	4.2	5.2	6.3	7.3	7.9	8.9	9.9	10.9
	100	56	6.6	8.8	10.9	13.1	15.2	16.5	18.6	20.7	22.8
	150	83	10.2	13.8	17.0	20.5	23.8	25.8	29.0	32.3	35.5
2.5	20	11	1.1	1.4	1.7	2.1	2.4	2.6	2.9	3.2	3.5
	50	28	2.7	3.6	4.4	5.2	6.1	6.6	7.4	8.2	9.0
	100	56	5.6	7.4	9.1	10.9	12.6	13.7	15.3	17.0	18.7
	150	83	8.7	11.6	14.2	17.0	19.7	21.3	23.9	26.5	29.1
3.0	20	11	0.9	1.2	1.5	1.8	2.0	2.2	2.5	2.7	3.0
	50	28	2.4	3.1	3.8	4.5	5.2	5.6	6.3	7.0	7.6
	100	56	4.9	6.5	7.9	9.4	10.8	11.7	13.1	14.5	15.9
	150	83	7.7	10.1	12.4	14.7	16.9	18.3	20.5	22.6	24.8
4.0	20	11	0.8	1.0	1.2	1.4	1.6	1.7	1.9	2.1	2.3
	50	28	2.0	2.5	3.1	3.6	4.1	4.4	5.0	5.5	6.0
	100	56	4.1	5.3	6.4	7.5	8.6	9.3	10.3	11.4	12.4
	150	83	6.4	8.3	10.0	11.8	13.4	14.5	16.1	17.8	19.4

Note: Multiply the W/ft heat loss values by 3.28 for W/m.

Table 3 Indoor Pipe Heat Loss Multiples

Fiberglass thickness (in)	Indoor multiple
0.5	0.79
1	0.88
1.5	0.91
2	0.93
2.5	0.94
3	0.95
4	0.97

Table 4 Insulation Heat Loss Multiples

k factor at 50°F (10°C) (BTU/hr-°F-ft ² /in)	Insulation multiple	Examples of preformed pipe insulation
0.1-0.2	0.6	Rigid cellular urethane (ASTM C591)
0.2-0.3	1.0	Glass fiber (ASTM C547) Foamed elastomer (ASTM C534)
0.3-0.4	1.4	Cellular glass (ASTM C552) Mineral fiber blanket (ASTM C553)

Pipe Freeze Protection and Flow Maintenance
1. Determine design conditions and pipe heat loss
2. Select the heating cable
3. Determine the heating cable length
4. Determine the electrical parameters
5. Select the connection kits and accessories
6. Select the control system
7. Select the power distribution
8. Complete the Bill of Materials

Step 2 Select the heating cable

To select the appropriate XL-Trace Edge heating cable for your application, you must determine your cable supply voltage, power output, and outer jacket. Once you select these, you will be able to determine the catalog number for your cable.

Heating Cable Catalog Number

Before beginning, take a moment to understand the structure underlying heating cable catalog numbers. You will refer to this numbering convention throughout the product selection process. Your goal is to determine the catalog number for the product that best suits your needs.

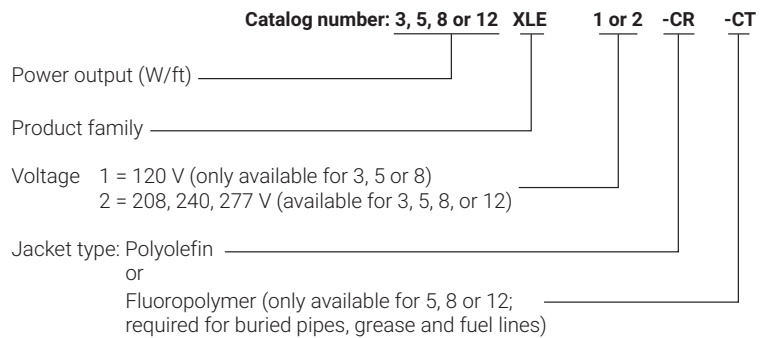
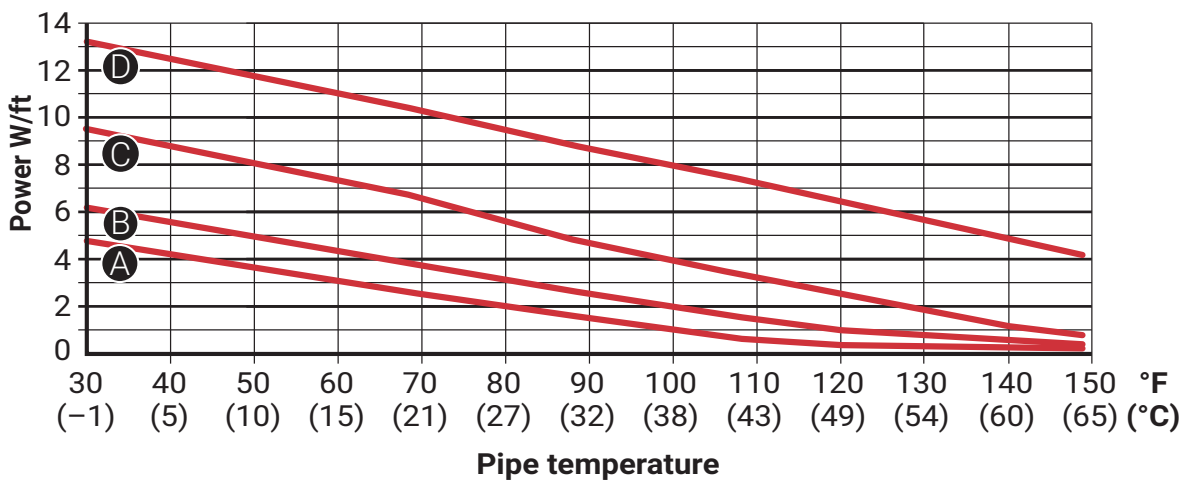

Fig. 11 Heating cable catalog number

Select the heating cable from Fig. 12 that provides the required power output to match the corrected heat loss for your application. Fig. 12 shows the power output for the heating cables on metal pipe at 120/240 volts. To correct the power output for other applied voltage or plastic pipes multiply the power output at the desired maintain temperature by the factors listed in Table 5. If the pipe heat loss, $Q_{CORRECTED}$, is between the two heating cable power output curves, select the higher-rated heating cable.



A 3XLE1-CR (120 V) 3XLE2-CR (240 V)	B 5XLE1-CR and 5XLE1-CT (120 V) 5XLE2-CR and 5XLE2-CT (240 V)	C 8XLE1-CR and 8XLE1-CT (120 V) 8XLE2-CR and 8XLE2-CT (240 V)	D 12XLE2-CR and 12XLE2-CT (240 V)
---	---	---	--

Fig. 12 Heating cable power output on metal pipe

Table 5 Power Output Correction Factors

Voltage correction factors	3XLE1	5XLE1	8XLE1	3XLE2	5XLE2	8XLE2	12XLE2
120 V	1.00	1.00	1.00	–	–	–	–
208 V	–	–	–	0.84	0.90	0.94	0.88
240 V	–	–	–	1.00	1.00	1.00	1.00
277 V	–	–	–	1.17	1.10	1.06	1.14
Plastic pipe correction factor (With AT-180 Aluminum tape)	0.75	0.75	0.75	0.75	0.75	0.75	0.75

Confirm that the corrected power output of the heating cable selected is greater than the corrected pipe heat loss ($Q_{CORRECTED}$). If $Q_{CORRECTED}$ is greater than the power output of the highest-rated heating cable, you can:

- Use two or more heating cables run in parallel
- Use thicker insulation to reduce heat loss
- Use insulation material with a lower k factor to reduce heat loss

Example: Pipe Freeze Protection – Water Piping

Pipe maintain temperature (T_M)	40°F (4°C) (from Step 1)
$Q_{CORRECTED}$	$Q_{CORRECTED} = 3.9 \text{ W/ft @ } T_M \text{ 40°F}$ (13.1 W/m @ T_M 4°C)
Supply voltage	120 V (from Step 1)
Pipe material	Plastic (from Step 1)
Select heating cable:	$Q_B = 3.9 \text{ W/ft @ } T_M \text{ 40°F}$ (from Step 1) 5XLE1 = 5.6 W/ft @ 40°F (from Fig. 12)
Supply voltage correction factor	1.00 (from Table 5)
Pipe material correction factor	Plastic = 0.75 (from Table 5)
Corrected heating cable power	5.6 W/ft x 1.00 x 0.75 = 4.2 W/ft
Selected heating cable	5XLE1

Example: Flow Maintenance – Grease Waste Line

Pipe maintain temperature (T_M)	110°F (43°C) (from Step 1)
$Q_{CORRECTED}$	4.0 W/ft @ T_M 110°F (13.1 W/m @ T_M 43°C)
Supply voltage	208 V (from Step 1)
Pipe material	Metal (from Step 1)
Select heating cable:	$Q_B = 4.0$ W/ft @ T_M 110°F (from Step 1) 12XLE2 = 7.0 W/ft @ 110°F (from Fig. 12)
Supply voltage correction factor	0.88 (from Table 5)
Pipe material correction factor	Metal = 1.00
Corrected heating cable power	7.0 x 0.88 x 1.00 = 6.2 W/ft
Selected heating cable	12XLE2

Confirm exposure temperature rating for the heating cable

Refer to Table 6 to verify that the maximum system temperature does not exceed the exposure temperature of the selected heating cable.

Table 6 Heating Cable Temperature Ratings

	3XLE1	3XLE2	5XLE1	5XLE2	8XLE1	8XLE2	12XLE2
Maximum maintain temperature (T_M)	154°F (68°C)	154°F (68°C)	154°F (68°C)	154°F (68°C)	154°F (68°C)	154°F (68°C)	150°F (65°C)
Maximum exposure temperature (T_{EXP})	185°F (85°C)	185°F (85°C)	185°F (85°C)	185°F (85°C)	185°F (85°C)	185°F (85°C)	185°F (85°C)

Example: Pipe Freeze Protection – Water Piping

Maximum system temperature (T_{MAX})	80°F (27°C) (from Step 1)
Selected heating cable	5XLE1 (from previous step)
Maximum heating cable exposure temperature (T_{EXP})	185°F (85°C) (from Table 6)
$T_{MAX} < T_{EXP}$	Yes

Example: Flow Maintenance - Grease Waste Line

Maximum system temperature (T_{MAX})	125°F (52°C) (from Step 1)
Selected heating cable	12XLE2 (from previous step)
Maximum heating cable exposure temperature (T_{EXP})	185°F (85°C) (from Table 6)
$T_{MAX} < T_{EXP}$	Yes

Select Outer Jacket

Select the appropriate heating cable outer jacket for the application.
Jacket options are:

- CR Compatible with most XL-Trace Edge applications
- CT Required for buried pipe freeze protection and for grease and fuel line flow maintenance; may be used in other XL-Trace Edge applications for improved mechanical strength and chemical resistance.

Example: Pipe Freeze Protection – Water Piping

Selection: 5XLE1-CR

Example: Flow Maintenance - Grease Waste Line

Selection: 12XLE2-CT

Pipe Freeze Protection and Flow Maintenance
1. Determine design conditions and pipe heat loss
2. Select the heating cable
3. Determine the heating cable length
4. Determine the electrical parameters
5. Select the connection kits and accessories
6. Select the control system
7. Select the power distribution
8. Complete the Bill of Materials

Step 3 Determine the heating cable length

In Step 2 you selected the appropriate heating cable and the number of runs of heating cable required for the pipe. Multiply the length of the pipe by the number of heating cable runs for the heating cable length.

$$\text{Heating cable length} = \text{Pipe length} \times \text{No. heating cable runs}$$

Additional heating cable will be required for heat sinks and connection kits. Use Table 7 and Table 8 to determine the additional footage required for heat sinks (valves, flanges, and pipe supports). You will determine the additional heating cable for connection kits in Step 5. Round up fractional lengths to ensure heating cable lengths are sufficient.

$$\text{Total heating cable length required} = (\text{Pipe length} \times \text{No. heating cable runs}) + \text{Additional heating cable for heat sinks (valves, pipe supports, and flanges)}$$

Table 7 Additional Heating Cable for Valves

Pipe diameter (IPS) (inches)	Heating cable (feet (meters))	
1/2	0.8	(0.24)
3/4	1.3	(0.4)
1	2.0	(0.6)
1-1/4	3.3	(1.1)
1-1/2	4.3	(1.3)
2	4.3	(1.3)
3	4.3	(1.3)
4	4.3	(1.3)
6	5.0	(1.5)
8	5.0	(1.5)
10	5.6	(1.7)
12	5.9	(1.9)
14	7.3	(2.2)
18	9.4	(2.9)
20	10.5	(3.2)

Table 8 Additional Heating Cable for Pipe Supports and Flanges

Support	Additional cable
Pipe hangers (insulated)	No additional heating cable
Pipe hangers noninsulated and U-bolt supports	Add 2x pipe diameter
Welded support shoes	Add 3x the length of the shoe
Flanges	Add 2x pipe diameter

Note: For applications where more than one heating cable is required per foot of pipe, this correction factor applies for each cable run.

Example: Pipe Freeze Protection – Water Piping

Pipe length	300 ft (91 m) (from Step 1)
Pipe diameter	2-inch plastic (from Step 1)
Number of heating cable runs	1 (from Step 2)
Valves	3 gate valves 4.3 ft x 3 gate valves = 12.9 ft (3.9 m)
Pipe supports	5 pipe hangers with U-bolts 2-inch pipe diameter = $2/12 = 0.17$ ft [0.17 ft pipe diameter x 2] x 5 pipe supports = 1.7 ft (0.5 m)
Flanges	0
Total heating cable for heat sinks	12.9 ft (3.9 m) + 1.7 ft (0.5 m) = 14.6 ft (4.4 m) Rounded up to 15 ft (5 m)
Total heating cable length required	300 ft (91 m) x 1 run + 15 ft = 315 ft (96 m) of 5XLE1-CR (Note: AT-180 Aluminum tape is required for installing heating cable on plastic pipe.)

Example: Flow Maintenance – Grease Waste Line

Pipe length	200 ft (61 m) (from Step 1)
Pipe diameter	4-inch metal (from Step 1)
Number of heating cable runs	1 (from Step 2)
Valves	2 gate valves [4.3 ft x 2 gate valves] x 1 run = 8.6 ft (2.6 m)
Pipe supports	2 non-insulated hangers 4-inch pipe diameter = $4/12 = 0.33$ ft [(0.33 ft pipe diameter x 2) x 2 pipe supports] x 1 run = 1.3 ft (0.4 m)
Flanges	2 4-inch pipe diameter = $4/12 = 0.33$ ft [(2 x 0.33 ft (pipe diameter)) x 2 flanges] x 1 run = 1.3 ft (0.4 m)
Total heating cable for heat sinks	8.6 ft (2.6 m) + 1.3 ft (0.4 m) + 1.3 ft (0.4 m) = 11.2 ft (2.2 m) Rounded up to 12 ft (3 m)
Total heating cable length required	200 ft x 1 run + 12 ft = 212 ft (65 m) of 12XLE2-CT

Pipe Freeze Protection and Flow Maintenance	
1.	Determine design conditions and pipe heat loss
2.	Select the heating cable
3.	Determine the heating cable length
4.	Determine the electrical parameters
5.	Select the connection kits and accessories
6.	Select the control system
7.	Select the power distribution
8.	Complete the Bill of Materials

Step 4 Determine the electrical parameters

To determine the electrical requirements for your application, you must determine the number of circuits and calculate the transformer load.

Determine Number of Circuits

To determine the number of circuits, you need to know:

- Total heating cable length
- Supply voltage
- Minimum start-up temperature

Use Table 9 to determine the maximum circuit length allowed. If the total heating cable length exceeds the maximum circuit length for the expected start-up temperature, more than one circuit will be required.

$$\text{Number of circuits} = \frac{\text{Heating cable length required}}{\text{Maximum heating cable circuit length}}$$

 **Important:** Select the smallest appropriate ground fault circuit breaker size.

 **WARNING:** To minimize the danger of fire from sustained electrical arcing if the heating cable is damaged or improperly installed, and to comply with the requirements of Raychem, agency certifications, and national electrical codes, ground fault equipment protection must be used on each heating cable branch circuit. Arcing may not be stopped by conventional circuit protection.

Table 9 Maximum Circuit Length in Feet

Start-up temperature (°F)	CB size (A)	40°F / 110°F Maintain*																				
		3XLE1			5XLE1			8XLE1			3XLE2			5XLE2			8XLE2			12XLE2		
		120 V	120 V	120 V	208 V	240 V	277 V	208 V	240 V	277 V	208 V	240 V	277 V	208 V	240 V	277 V	208 V	240 V	277 V			
-20°F	15	134	96	75	258	250	247	201	209	221	138	116	99	127	129	130						
	20	179	129	100	344	334	329	268	279	294	210	180	148	169	171	174						
	30	269	193	150	517	501	494	402	419	441	316	341	370	253	257	260						
	40	335	207	151	689	668	644	469	474	487	339	359	384	338	343	347						
0°F	15	156	112	84	307	298	294	227	237	250	170	142	120	129	131	133						
	20	209	149	113	410	397	392	303	316	333	236	239	190	172	175	177						
	30	313	223	169	615	596	587	455	474	499	354	382	414	258	262	265						
	40	368	245	173	696	732	708	535	544	558	384	407	435	340/344	349	354						
20°F	15	189	132	98	376	365	359	262	273	288	200	185	154	144	146	148						
	20	252	176	131	501	486	479	349	364	383	267	288	276	192	194	197						
	30	368	264	196	696	729	718	523	546	575	400	432	469	287	292	296						
	40	368	287	205	696	732	776	535	584	642	407/442	452/467	499	340/383	360/389	380/394						
40°F	15	242	160	117	492	478	471	311	324	342	232	250	221	162	165	167						
	20	323	214	156	656	637	628	414	432	456	309	334	362	216	219	222						
	30	368	287	223	696	732	776	535	584	642	407/464	452/500	504/543	324	329	333						
	40	368	287	223	696	732	776	535	584	642	407/526	452/555	504/591	340/430	360/439	380/444						
50°F	15	-	-	-	-	-	-	-	-	-	253	273	296	173	176	178						
	20	-	-	-	-	-	-	-	-	-	337	364	395	231	234	237						
	30	-	-	-	-	-	-	-	-	-	506	546	592	346	352	356						
	40	-	-	-	-	-	-	-	-	-	586	617	656	430	460	475						
65°F	15	-	-	-	-	-	-	-	-	-	296	319	347	192	195	197						
	20	-	-	-	-	-	-	-	-	-	395	426	462	256	260	263						
	30	-	-	-	-	-	-	-	-	-	592	639	693	384	390	395						
	40	-	-	-	-	-	-	-	-	-	686	756	801	430	460	490						

* When maximum circuit length is listed in:
 - black type, the value is for applications with a 40°F maintain
 - red type, the value is for applications with a 110°F maintain

Table 10 Maximum Circuit Length in Meters

		4°C / 43°C Maintain*														
Start-up temperature (°C)	CB size (A)	3XLE1	5XLE1	8XLE1	3XLE2			5XLE2			8XLE2			12XLE2		
		120 V	120 V	120 V	208 V	240 V	277 V	208 V	240 V	277 V	208 V	240 V	277 V	208 V	240 V	277 V
-29°C	15	41	29	23	79	76	75	61	64	67	42	35	30	39	39	40
	20	55	39	30	105	102	100	82	85	90	64	55	45	52	52	53
	30	82	59	46	158	153	151	123	128	134	96	104	113	77	78	79
	40	102	63	46	210	204	196	143	145	148	103	109	117	103	105	106
-18°C	15	48	34	26	94	91	90	69	72	76	52	43	37	39	40	41
	20	64	45	34	125	121	120	92	96	102	72	73	58	52	53	54
	30	95	68	52	188	182	179	139	145	152	108	116	126	79	80	81
	40	112	75	53	212	223	216	163	166	170	117	124	133	104/105	106	108
-7°C	15	58	40	30	115	111	109	80	83	88	61	56	47	44	45	45
	20	77	54	40	153	148	146	106	111	117	81	88	84	59	59	60
	30	112	80	60	212	222	219	159	166	175	122	132	143	88	89	90
	40	112	88	63	212	223	237	163	178	196	124/135	138/142	152	104/117	110/119	116/120
4°C	15	74	49	36	150	146	144	95	99	104	71	76	67	49	50	51
	20	98	65	48	200	194	191	126	132	139	94	102	110	66	67	68
	30	112	88	68	212	223	237	163	178	196	124/160	138/169	154/180	99	100	102
	40	112	88	68	212	223	237	163	178	196	124/160	138/169	154/180	104/131	110/134	116/135
10°C	15	-	-	-	-	-	-	-	-	-	77	83	90	53	54	54
	20	-	-	-	-	-	-	-	-	-	103	111	120	70	71	72
	30	-	-	-	-	-	-	-	-	-	154	166	180	105	107	109
	40	-	-	-	-	-	-	-	-	-	179	188	200	131	140	145
18°C	15	-	-	-	-	-	-	-	-	-	90	97	106	59	59	60
	20	-	-	-	-	-	-	-	-	-	120	130	141	78	79	80
	30	-	-	-	-	-	-	-	-	-	180	195	211	117	119	120
	40	-	-	-	-	-	-	-	-	-	209	230	244	131	140	149

*When maximum circuit length is listed in:
 - black type, the value is for applications with a 40°F maintain
 - red type, the value is for applications with a 110°F maintain

Example: Pipe Freeze Protection – Water Piping

Total heating cable length 315 ft of 5XLE1-CR (from Step 3)
 Supply voltage 120 V (from Step 1)
 Minimum start-up temperature -20°F (-29°C) (from Step 1)
 Circuit breaking sizing 30A
 Number of circuits 315 ft / (193 ft max CL) = 1.6 circuits
Round up to 2 circuits

Example: Flow Maintenance – Grease Waste Line

Total heating cable length 223 ft of 12XLE2-CT (from Step 3)
 Supply voltage 208 V (from Step 1)
 Minimum start-up temperature 50°F (10°C) (from Step 1)
 Circuit breaking sizing 30A
 Number of circuits 223 ft / 346 ft = 0.6 circuits
Round up to 1 circuit

Example: Flow Maintenance – Grease Waste Line

Total heating cable length 212 ft of 12XLE2-CT (from Step 3)
 Supply voltage 208 V
 Minimum start-up temperature 50°F (10°C) (from Step 1)

$$\frac{\text{Max A/ft at 50°F} \times \text{Total feet}}{\text{Supply voltage}} = \frac{0.074 \text{ A/ft} \times 212 \text{ ft} \times 208 \text{ V}}{1000} = 3.3 \text{ kW}$$

Transformer load (kW) = 3.3 kW

Pipe Freeze Protection and Flow Maintenance	
1.	Determine design conditions and pipe heat loss
2.	Select the heating cable
3.	Determine the heating cable length
4.	Determine the electrical parameters
5.	Select the connection kits and accessories
6.	Select the control system
7.	Select the power distribution
8.	Complete the Bill of Materials

Step 5 Select the connection kits and accessories

All XL-Trace Edge systems require a power connection and end seal kit. Splice and tee kits are used as required. Use Table 13 on page 27 (for aboveground applications) and Table 15 on page 29 (for buried applications) to select the appropriate connection kits.

Note: Add extra cable on your Bill of Materials for power connections, tees, and end seals. See Table 13 on page 27, Table 15 on page 29, and Table 16 on page 30 for more information.

WARNING: Approvals and performance are based on the use of Raychem -specified parts only. Do not substitute parts or use vinyl electrical tape.

ABOVEGROUND PIPING

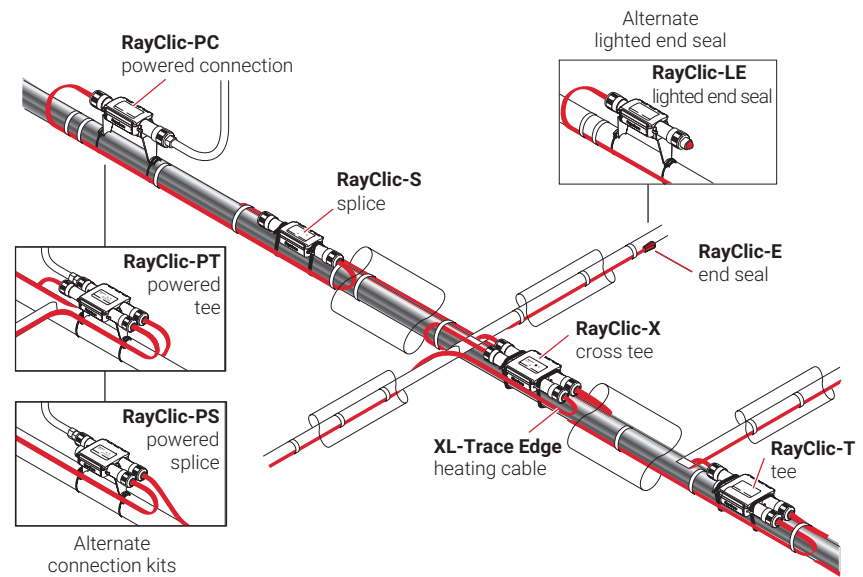

Fig. 13 RayClic connection system

Use the following table for general piping, and grease waste and fuel lines. Develop a bill of materials from the connection kits listed in this table.

Note: Connection kits must be off the pipe when installed on grease waste, fuel oil, or pipes exceeding 150°F (65°C).

Table 13 Connection Kits and Accessories for Aboveground Piping







	Catalog number	Description	Standard packaging	Usage	Heating cable allowance ¹
Connection kits					
	RayClic-PC	Power connection and end seal (RayClic-SB-04 pipe mounting bracket included)	1	1 per circuit	2 ft (0.6 m)
	RayClic-PS	Powered splice and end seal (RayClic-SB-04 pipe mounting bracket included)	1	1 per circuit	4 ft (1.2 m)
	RayClic-PT	Powered tee and end seal (RayClic-SB-04 pipe mounting bracket included)	1	1 per circuit	6 ft (1.8 m)
	FTC-P ²	Power connection and end seal kit Note: FTC-P is required for circuits requiring 40 A circuit breakers.	1	1 per circuit	2 ft (0.6 m)
	RayClic-S	Splice used to join two sections of heating cable	1	As required	2 ft (0.6 m)
	RayClic-T	Tee kit with end seal; use as needed for pipe branches	1	As required	2 ft (0.6 m)
	RayClic-X	Cross connection to connect four heating cables	1	As required	8 ft (2.4 m)
	FTC-HST - PLUS ³	Low-profile splice/tee; use as needed for pipe branches	2	As required	2 ft (0.6 m) for a splice 3 ft (0.9 m) for a tee
	RayClic-LE	Lighted end seal (RayClic-SB-04 pipe mounting bracket included)	1	Alternate end seal	2 ft (0.6 m)
	RayClic-E	Replacement end seal	1	Additional end seal	0.3 ft (0.1 m)

Table 13 Connection Kits and Accessories for Aboveground Piping

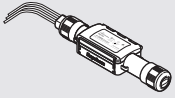
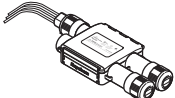
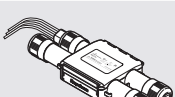
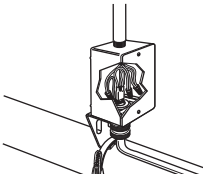
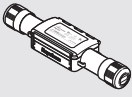
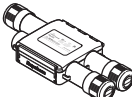
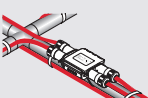
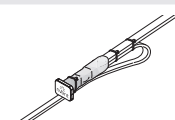
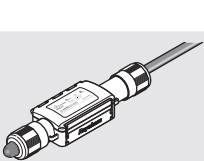
	Catalog number	Description	Standard packaging	Usage	Heating cable allowance ¹
Accessories					
	RayClic-SB-04	Pipe mounting bracket. Required for mounting the kits off the pipe for exposure temperatures greater than 150°F (65°C) and for grease and fuel line splices and tees.	1	As required	-
	RayClic-SB-02	Wall mounting bracket	1	As required	-
	ETL	"Electric Traced" label (use 1 label per 10 feet of pipe)	1	1 label per 10 feet (3 m) of pipe	-
	GT-66	Glass cloth adhesive tape for attaching heating cable to pipe at 40°F (4°C) or above.	66 ft (20 m)	See Table 14	-
	GS-54	Glass cloth adhesive tape for attaching heating cable to pipe above -40°F (-40°C).	54 ft (20 m)	See Table 14	-
	AT-180	Aluminum tape. Required for attaching heating cable to plastic pipe (use 1 foot of tape per foot of heating cable).	180 ft (55 m)	1 ft/ft [0.3 m/m] of heating cable	-

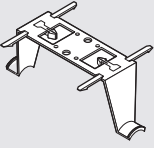
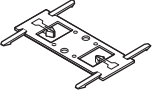
¹ Allow extra heating cable for ease of component installation.

² Junction box not included.

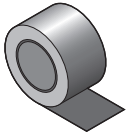
³ One RayClic-E end seal is required for each FTC-HST-PLUS used as a tee kit.

Table 14 Quantity of Glass Cloth Adhesive Tape Required (attach at 1-foot intervals)

Pipe size (in)	<2	3	4	6	8	10
Feet of pipe per GT-66 roll	60 (18 m)	50 (15 m)	40 (12 m)	25 (8 m)	20 (6 m)	15 (5 m)
Feet of pipe per GS-54 roll	49 (15 m)	41 (13 m)	33 (10 m)	20 (6 m)	16 (5 m)	12 (4 m)

Buried Piping

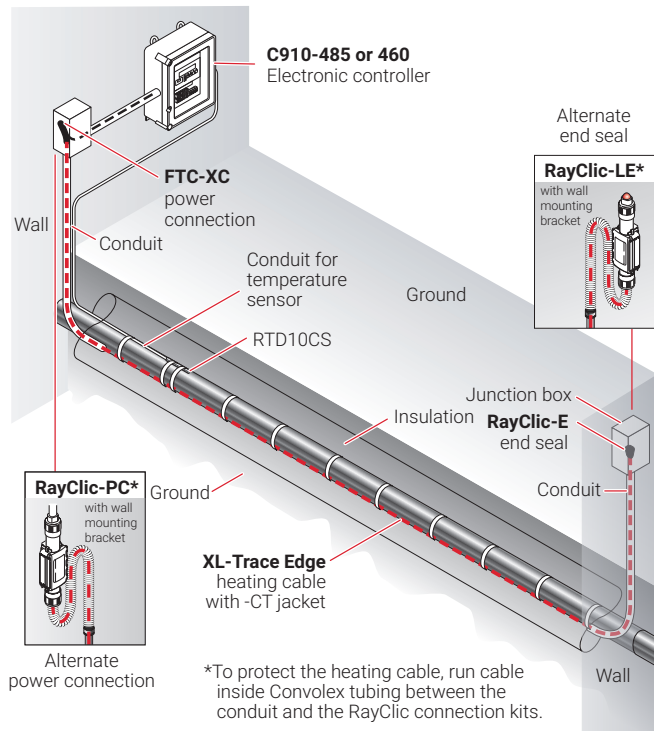

Fig. 14 Typical buried piping system

Use the following for buried water piping and grease waste lines. Note that all connections must be aboveground and that no splices/tees are allowed. Develop a bill of materials from the connection kits in this table.

Table 15 Connection Kits and Accessories for Buried Piping







	Catalog number	Description	Standard packaging	Usage	Heating cable allowance ¹
	RayClic-PC	Power connection and end seal (RayClic-SB-04 pipe mounting bracket included)	1	1 per circuit	2 ft (0.6 m)
	FTC-XC	The FTC-XC power connection and end seal kit is for use with XL-Trace Edge heating cable that is run through conduit to a junction box. Materials for one power connection and end seal is included in the kit. Note: FTC-XC is required for circuits requiring 40 A circuit breakers.	1	1 per circuit	2 ft (0.6 m)
	RayClic-LE	Lighted end seal (RayClic-SB-04 pipe mounting bracket included)	1	Alternate end seal	2 ft (0.6 m)
	RayClic-E	Replacement end seal	1	Additional end seal	0.3 ft (0.1 m)

Table 15 Connection Kits and Accessories for Buried Piping

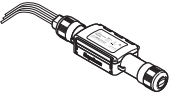
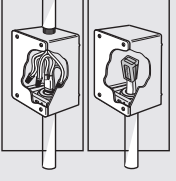
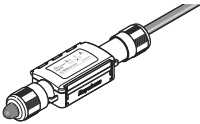
	Catalog number	Description	Standard packaging	Usage	Heating cable allowance ¹
Accessories					
	RayClic-SB-04	Pipe mounting bracket	1	As required	-
	RayClic-SB-02	Wall mounting bracket	1	As required	-
	ETL	"Electric Traced" label (use 1 label per 10 feet of pipe)	1	1 label per 10 feet (3 m) of pipe	-
	GT-66	Glass cloth adhesive tape for attaching heating cable to pipe at 40°F (4°C) or above.	66 ft (20 m)	See Table 16	-
	GS-54	Glass cloth adhesive tape for attaching heating cable to pipe above -40°F (-40°C).	54 ft (20 m)	See Table 16	-
	AT-180	Aluminum tape. Required for attaching heating cable to plastic pipe (use 1 foot of tape per foot of heating cable).	180 ft (55 m)	1 ft/ft [0.3 m/m] of heating cable	-

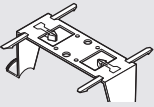
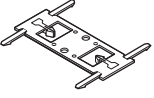
¹ Allow extra heating cable for ease of component installation.

Table 16 Quantity of Glass Cloth Adhesive Tape Required (attach at 1-foot intervals)

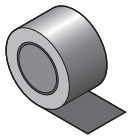
Pipe size (in)	<2	3	4	6	8	10
Feet of pipe per GT-66 roll	60 (18 m)	50 (15 m)	40 (12 m)	25 (8 m)	20 (6 m)	15 (5 m)
Feet of pipe per GS-54 roll	49 (15 m)	41 (13 m)	33 (10 m)	20 (6 m)	16 (5 m)	12 (4 m)

Pipe Freeze Protection and Flow Maintenance
1. Determine design conditions and pipe heat loss
2. Select the heating cable
3. Determine the heating cable length
4. Determine the electrical parameters
5. Select the connection kits and accessories
6. Select the control system
7. Select the power distribution
8. Complete the Bill of Materials

Step 6 Select the control system

Temperature controls save energy by ensuring that the system is energized only when necessary. Raychem offers a wide variety of monitoring and control options, including:

- Electronic thermostats provide higher accuracy of the heating cable circuit with thermistor sensors and built-in ground fault protection.
- Electronic controllers provide superior accuracy with RTD temperature sensors, built-in ground fault protection, monitoring and alarm output.
- Modbus® protocol communication over RS-485 system is supported using Raychem ProtoNode multi-protocol gateways.

 **Note:** Grease waste flow maintenance requires line sensing controllers such as the Raychem ECW-GF, C910-485, or the ACS-30.





Use the following table to identify the control system suitable for your application. Contact your Raychem representative or contact Raychem directly at (800) 545-6258 for more information.

Table 17 Temperature Control Options

Application	Electronic thermostat ECW-GF	Electronic controllers		
		Single-point 460	Single-point C910-485	Multipoint ACS-30
Ambient sensing	x	x	x	x
Line sensing	x	x	x	x
Buried pipe	x	x	x	x
Sensor	Thermistor	Thermistor	RTD*	RTD*
Sensor length	35 ft	10 ft	multiple options	multiple options
Set point range	32°F to 200°F (0°C to 93°C)	32°F to 176°F (0°C to 80°C)	-76°F to 1058°F (-60°C to 570°C)	"
Enclosure	NEMA 4X	Type 12 - indoor use	NEMA 4X	"
Deadband	2°F to 10°F (2°C to 6°C)	1°F to 8°F (1°C to 4°C)	3°F (1.6°C)	"
Enclosure limits	-40°F to 140°F (-40°C to 60°C)	-4°F to 122°F (-20°C to 50°C)	-40°F to 140°F (-40°C to 60°C)	"
Switch rating	30 A	24 A	30 A	"
Switch type	DPST	SPST	DPST	"
Electrical rating	100–277 V	120–277 V	100–277 V	"
Approvals	c-UL-us	c-UL-us	c-CSA-us	"
Ground fault protection	30 mA fixed	20 mA to 200 mA	20 mA to 250 mA	"
AC relay	2 A at 277 Vac	1 A at 24 Vac	100–277 V, 0.75 A max.	"
Dry contact relay	2 A at 48 Vdc	24Vac/dc, 1A max.	48 Vac/dc, 500 mA max.	"

* not included with unit

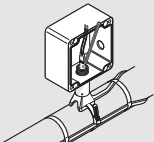
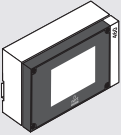
Table 18 Control Systems

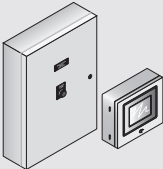
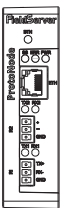
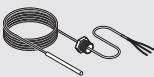
	Catalog number	Description
Electronic Thermostats and Accessories		
	ECW-GF	The ECW-GF electronic controller provides accurate temperature control with integrated 30-mA ground fault protection. The controller can be programmed to maintain temperatures up to 200°F (93°C) at voltages from 100 to 277 V and can switch current up to 30 Amperes. The ECW-GF is complete with a 25-ft (7.6-m) temperature sensor for line, slab or ambient sensing temperature control, and is housed in a NEMA 4X rated enclosure. The controller features an AC/DC dry alarm contact relay.
	ECW-GF-DP	An optional remote display panel (ECW-GF-DP) can be added to provide ground fault or alarm indication in applications where the controller is mounted in inaccessible locations.
	FTC-PSK	The FTC-PSK pipe stand and power connection kit is for use with XL-Trace Edge heating cables. The stand is designed specifically for the ECW-GF electronic controllers and is compatible with other junction boxes that have 1 inch NPT entries, threaded or non-threaded. Materials for one power connection and end seal are included in the kit.
Electronic Controllers and Sensors		
	460	The 460 is a single point heat tracing controller designed for pipe freeze protection and flow maintenance systems. It includes a 5" inch color touch screen display for intuitive set up and programming right out of the box. The 460 controller may be used with line-sensing or ambient-sensing and proportional ambient-sensing control (PASC) modes. It measures temperatures with two Thermistor 2 KOhm / 77°F (25°C), 2-wire connected directly to the unit. The controller can also measure ground fault current to ensure system integrity.
	C910-485	The C910-485 is a compact, full-featured microprocessor-based single-point heat-trace controller. The C910-485 provides control and monitoring of electrical heat-tracing circuits for both freeze protection and temperature maintenance, and can be set to monitor and alarm for high and low temperature, high and low current, ground fault level, and voltage. The C910-485 controller is available with an electromechanical relay (EMR) for use in ordinary areas. The C910-485 comes with an RS-485 communication module.
	ACS-UIT3 ACS-PCM2-5	The ACS-30 Advanced Commercial Control System is a multipoint electronic control and monitoring system for heat-tracing used in commercial freeze protection and flow maintenance applications. The ACS-30 system can control up to 260 circuits with multiple networked ACS-PCM2-5 panels, with a single ACS-UIT3 user interface terminal. The ACS-PCM2-5 panel can directly control up to 5 individual heat-tracing circuits using electromechanical relays rated at 30 A up to 277 V.
	ProtoNode-RER-1.5K ProtoNode-RER-10K	ProtoNode is an external, high performance multi-protocol gateway for customers needing protocol translation between building management systems (BMS) using BACnet® or Metasys® N2 and the C910-485, ACS-30 controller. ProtoNode-RER-1.5K (Part No 2000004256) is for C910-485 or ACS-30 systems with up to 5 PCM panels. ProtoNode-RER-10K (Part No 2000004257) is for ACS-30 systems with up to 34 PCM panels.
	RTD-200 RTD3CS RTD10CS RTD50CS	Stainless steel jacketed three-wire RTD (Resistance Temperature Detector) used with C910-485 and ACS-30 controllers. RTD-200: 3 in (76 mm) temperature sensor with a 6 ft (1.8 m) lead wire and ½ in NPT bushing RTD3CS: temperature sensor with a 3 ft (0.9 m) flexible armor, 18 in (457 mm) lead wire and ½ in NPT bushing RTD10CS: temperature sensor with a 10 ft (3 m) flexible armor, 18 in (457 mm) lead wire and ½ in NPT bushing RTD50CS: temperature sensor with a 50 ft (15 m) flexible armor, 18 in (457 mm) lead wire and ½ in NPT bushing

Pipe Freeze Protection and Flow Maintenance	
1.	Determine design conditions and pipe heat loss
2.	Select the heating cable
3.	Determine the heating cable length
4.	Determine the electrical parameters
5.	Select the connection kits and accessories
6.	Select the control system
7.	Select the power distribution
8.	Complete the Bill of Materials

Step 7 Select the power distribution

Once the heating cable circuits have been defined, you must select how to provide power to them. Power to the XL-Trace Edge heating cables can be provided in several ways: directly through the temperature control, through external contactors, or through HTPG power distribution panels.

Single circuit control

Heating cable circuits that do not exceed the current rating of the selected temperature control device shown in Table 18 can be switched directly (see Fig. 15).

Group control

If the current draw exceeds the switch rating, or if the controller will activate more than one circuit (group control, an external contactor must be used (see Fig. 15 on page 33).

Large systems with many circuits should use an HTPG power distribution panel. The HTPG is a dedicated power-distribution, control, ground fault protection, monitoring, and alarm panel for freeze protection and broad temperature maintenance heat-tracing applications. This enclosure contains an assembled circuit-breaker panelboard. Panels are equipped with ground fault circuit breakers with or without alarm contacts. The group control package allows the system to operate automatically in conjunction with an ambient-sensing thermostat, individual electronic, or duty cycle controller.

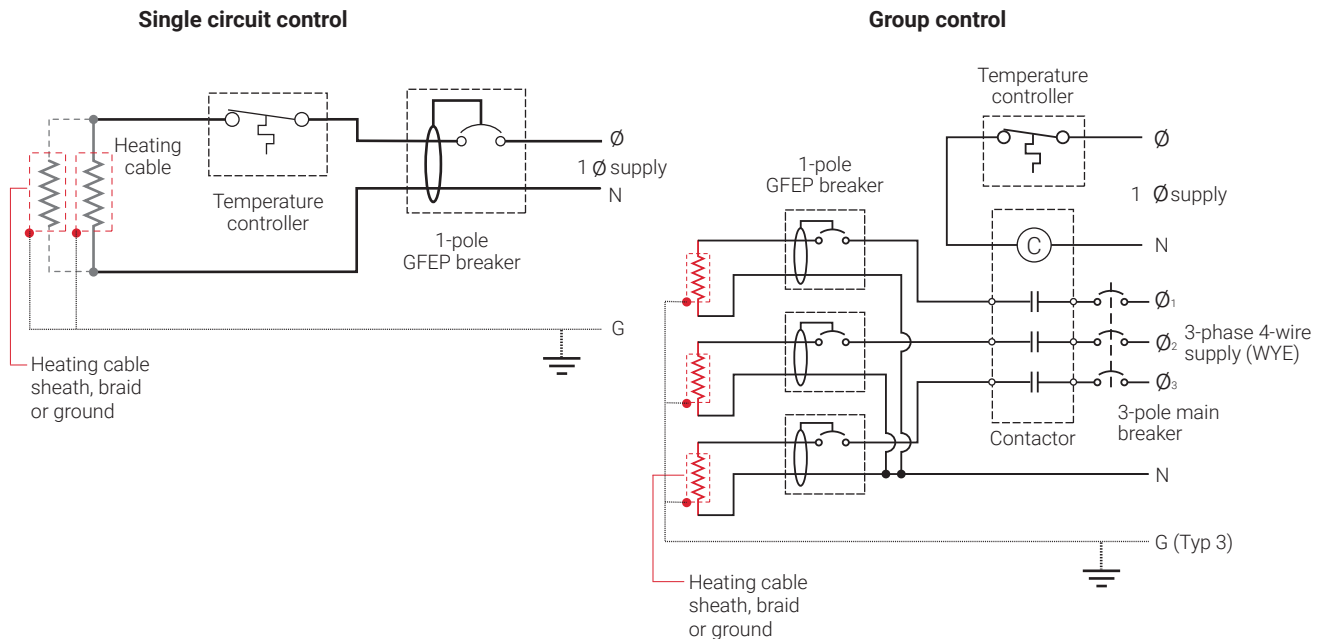

Fig. 15 Single circuit and group control

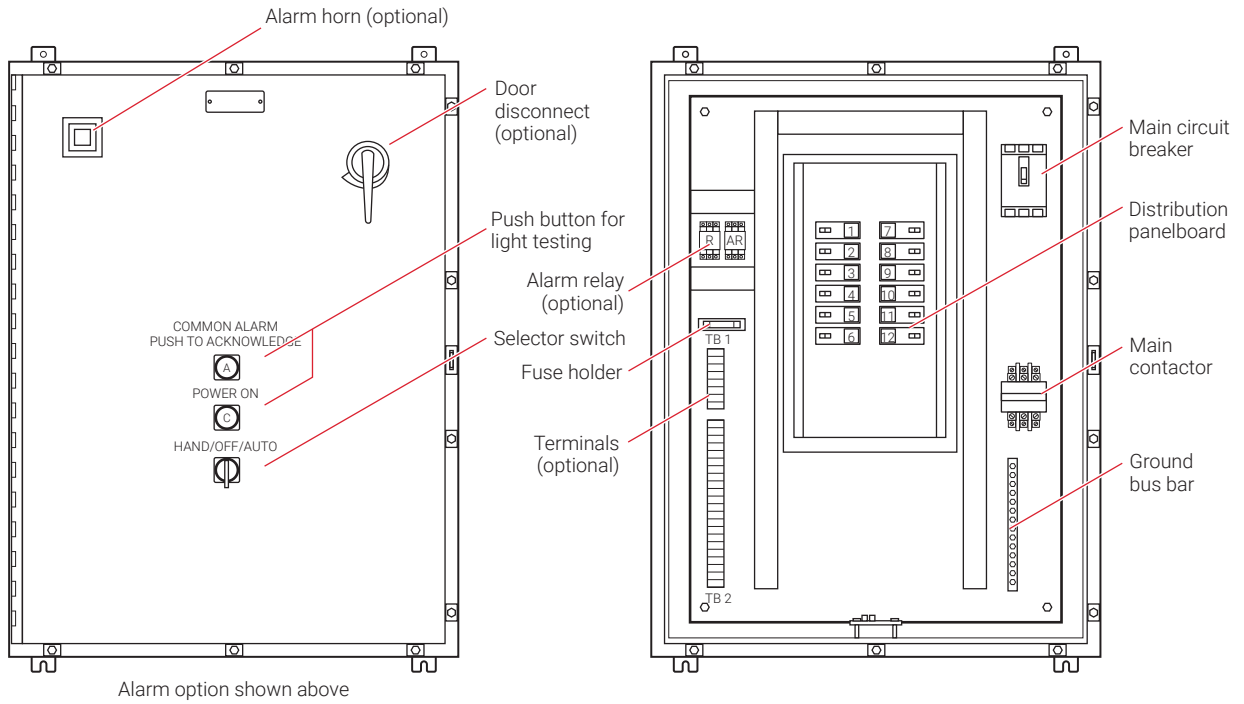

Fig. 16 HTPG power distribution panel

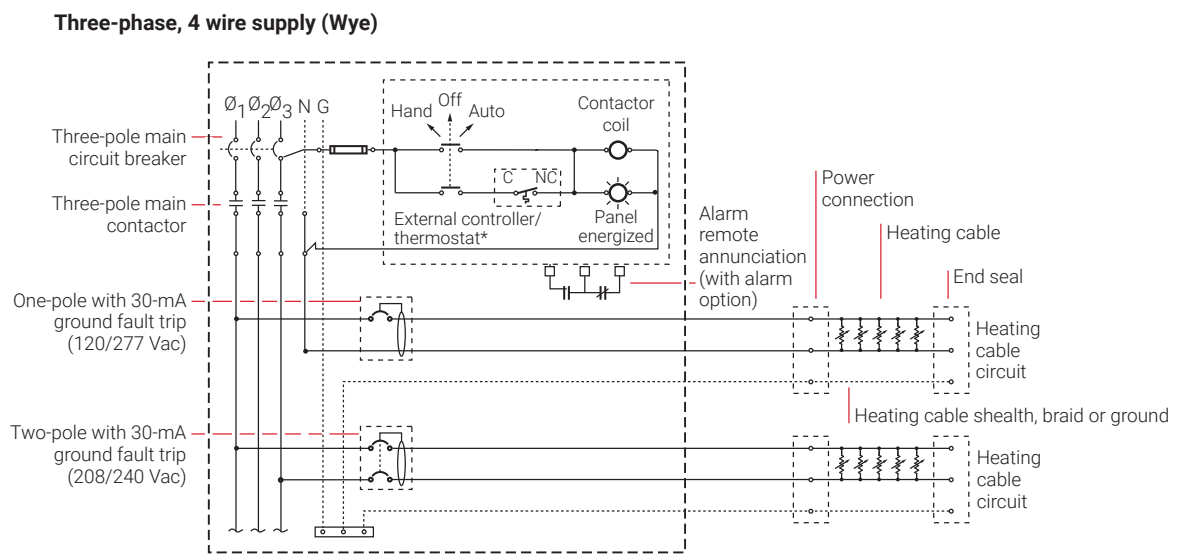
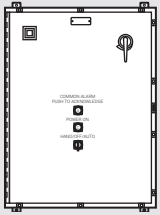

Fig. 17 HTPG power schematic

Table 19 Power Distribution

	Catalog number	Description
Power Distribution		
	HTPG	Heat-tracing power distribution panel with ground fault and monitoring for group control.

Pipe Freeze Protection and Flow Maintenance
1. Determine design conditions and pipe heat loss
2. Select the heating cable
3. Determine the heating cable length
4. Determine the electrical parameters
5. Select the connection kits and accessories
6. Select the control system
7. Select the power distribution
8. Complete the Bill of Materials

Step 8 Complete the Bill of Materials

If you used the Design Worksheet to document all your design parameters, you should have all the details necessary complete your Bill of Materials.

Step 1 Determine design conditions and pipe heat loss

Design conditions

XL-Trace Edge application	Location	Maintain temp. (T _M)	Max. system temp. (T _{MAX})	Min. ambient temp. (T _A)	Pipe diameter and material	Pipe length	Thermal insulation type and thickness	
Pipe freeze protection								
<input type="checkbox"/> Water piping	<input type="checkbox"/> Indoors <input type="checkbox"/> Outdoors	<input type="checkbox"/> Aboveground <input type="checkbox"/> Buried	_____	_____	_____	_____ in	<input type="checkbox"/> Metal <input type="checkbox"/> Plastic	<input type="checkbox"/> Fiberglass <input type="checkbox"/> _____ in
Flow maintenance								
<input type="checkbox"/> Grease waste lines	<input type="checkbox"/> Indoors <input type="checkbox"/> Outdoors	<input type="checkbox"/> Aboveground <input type="checkbox"/> Buried	_____	_____	_____	_____ in	<input type="checkbox"/> Metal <input type="checkbox"/> Plastic	<input type="checkbox"/> Fiberglass <input type="checkbox"/> _____ in
<input type="checkbox"/> Fuel lines	<input type="checkbox"/> Indoors <input type="checkbox"/> Outdoors	<input type="checkbox"/> Aboveground <input type="checkbox"/> Buried	_____	_____	_____	_____ in	<input type="checkbox"/> Metal <input type="checkbox"/> Plastic	<input type="checkbox"/> Fiberglass <input type="checkbox"/> _____ in

Example:
 Water piping Aboveground
 Outdoor Buried **40°F** **80°F** **-20°F** **2 in** Plastic **300 ft** Fiberglass **1 in**

Pipe heat loss

Calculate temperature differential ΔT

Pipe maintain temperature (T_M) _____
°F (°C)

Ambient temperature (T_A) _____
°F (°C)

$$\frac{\text{_____}}{T_M} - \frac{\text{_____}}{T_A} \longrightarrow = \frac{\text{_____}}{\Delta T}$$

Example: Pipe Freeze Protection – Water Piping

Pipe maintain temperature (T_M) 40 °F (from Step 1)
°F

Ambient temperature (T_A) -20 °F (from Step 1)
°F

$$\frac{40 \text{ °F}}{T_M} - \frac{-20 \text{ °F}}{T_A} \longrightarrow = \frac{60 \text{ °F}}{\Delta T}$$

Determine the pipe heat loss: See Table 2 for the base heat loss of the pipe (Q_B). If the ΔT for your system is not listed, interpolate between the two closest values.

Q_{B-50} $\Delta T1$	<u> </u> W/ft (W/m)
Q_{B-100} $\Delta T2$	<u> </u> W/ft (W/m)
Q_B	<u> </u> W/ft (W/m)
Pipe diameter	<u> </u> in
Insulation thickness	<u> </u> in
ΔT	<u> </u> °F (°C)
Q_{B-50}	<u> </u> W/ft (W/m)
Q_{B-100}	<u> </u> W/ft (W/m)

Example: Pipe Freeze Protection – Water Piping

Pipe diameter	<u> 2 in </u>
Insulation thickness	<u> 1 in </u>
ΔT	<u> 60°F </u>
Q_{B-50}	<u> 3.2 W/ft </u>
Q_{B-100}	<u> 6.8 W/ft </u>
ΔT interpolation	ΔT 60°F is 20% of the distance between ΔT 50°F and ΔT 100°F $Q_{B-50} + [0.20 \times (Q_{B-100} - Q_{B-50})]$
Q_{B-60}	$3.2 + [0.20 \times (6.8 - 3.2)] = 3.9$ W/ft
Pipe heat loss (Q_{B-60})	3.9 W/ft @ T_M 40°F

Compensate for insulation type and pipe location

See Table 2 for the pipe heat loss (Q_B). If the ΔT for your system is not listed, interpolate between the two closest values.

See Table 3 for indoor multiple

See Table 4 for insulation multiple

Location _____

Insulation thickness and type _____

Q_B _____
W/ft (W/m)

Insulation multiple _____

Indoor multiple (if applicable) _____

$$\frac{Q_B}{Q_B} \times \frac{\text{Insulation multiple}}{\text{Insulation multiple}} \times \frac{\text{Indoor multiple (if applicable)}}{\text{Indoor multiple (if applicable)}} = Q_{\text{CORRECTED}}$$

Example: Pipe Freeze Protection – Water Piping

Location Aboveground, indoor

Thermal insulation thickness and type 1-in fiberglass

Q_B 3.9 W/ft @ T_M 40°F

Insulation multiple 1.00

Indoor multiple N/A

$$Q_{\text{CORRECTED}} = \frac{3.9 \text{ W/ft}}{Q_B} \times \frac{1.00}{\text{Insulation multiple}} = 3.9 \text{ W/ft @ } T_M \text{ 40°F}$$

Step 2 Select the heating cable

Power output data: See Fig. 12

Power output correction factors: See Table 5

Heating cable temperature ratings: See Table 6

Pipe maintain temperature (T_M)	_____	(from Step 1)
Corrected heat loss ($Q_{CORRECTED}$)	_____	(from Step 1)
Supply voltage	_____	(from Step 1)
Pipe material (metal or plastic)	_____	(from Step 1)
XL-Trace Edge application (water, fuel oil, or greasy waste)	_____	(from Step 1)
Pipe freeze protection: general water piping, sprinkler piping	_____	
Flow maintenance: greasy waste lines, fuel lines	_____	
Maximum system use temperature (T_{MAX})	_____	(from Step 1)
Heating cable selected	_____	(from Step 1)
Power at T_M (120/208 V)	_____	
Power output correction factor	_____	(from Step 1)
Plastic pipe correction factor	_____	
_____ x _____ = _____		
Power at rated V factor	Plastic pipe correction factor	Corrected power

Is the heating cable power output ($P_{CORRECTED}$) \geq the corrected heat loss? Yes No

If No, then design with additional runs of heating cable or thicker thermal insulation.

Example: Pipe Freeze Protection – Water Piping

Maintain temperature (T_M)	_____	40°F
Corrected heat loss ($Q_{CORRECTED}$)	_____	3.9 W/ft @ T_M 40°F
Supply voltage	_____	120 V
Pipe material (metal or plastic*) (*AT-180 aluminum tape required for installing heating cable on plastic pipes)	_____	plastic

$$Q_B = 3.9 \text{ W/ft @ } T_M \text{ 40°F}$$

Select curve C: 5XLE1 = **5.6 W/ft @ 40°F**

Power output correction factor: 120 V = 1.00

Pipe material correction factor: Plastic = 0.75

Corrected heating cable power: 5.6 @/ft x 1.00 x 0.75 = **4.2 W/ft**

Select: **5XLE1**

Maximum system temperature (T_{MAX}): 80°F

Maximum heating cable exposure temperature (T_{EXP}): 150°F

$T_{MAX} < T_{EXP}$: Yes

Select outer jacket

-CR

-CT

Example: Pipe Freeze Protection – Water Piping

5XLE1-CR

Step 3 Determine the heating cable length

For additional heating cable allowance for valves: See Table 7.

For additional heating cable allowance for pipe supports and flanges: See Table 8.

Heat sinks

$$\frac{\text{Type of valves}}{\text{How many}} \times \frac{\text{Additional heating cable}}{\text{Additional heating cable}} = \frac{\text{Total heating cable for valves}}{\text{Total heating cable for valves}}$$

$$\frac{\text{Type of pipe supports}}{\text{How many}} \times \frac{\text{Additional heating cable}}{\text{Additional heating cable *2-in pipe diameter = 0.17 ft}} = \frac{\text{Total heating cable for pipe supports}}{\text{Total heating cable for pipe supports}}$$

$$\frac{\text{Type of flanges}}{\text{How many}} \times \frac{\text{Additional heating cable}}{\text{Additional heating cable}} = \frac{\text{Total heating cable for flanges}}{\text{Total heating cable for flanges}}$$

Total heating cable for heat sinks: _____

Total heating cable length

$$\left(\frac{\text{Pipe length}}{\text{Pipe length}} \times \frac{\text{Number of heating cable runs}}{\text{Number of heating cable runs}} \right) + \frac{\text{Additional cable for valves, pipe supports, and flanges}}{\text{Additional cable for valves, pipe supports, and flanges}} = \frac{\text{Total heating cable length required}}{\text{Total heating cable length required}}$$

Example:

Heat sinks

$$\frac{\text{Gate valves}}{\text{How many}} \times \frac{\text{Additional heating cable}}{\text{Additional heating cable}} = \frac{\text{Total}}{\text{Total}}$$

$$\frac{\text{Pipe hangers noninsulated and U-bolt supports}}{\text{How many}} \times \frac{\text{Additional heating cable}}{\text{Additional heating cable *2-in pipe diameter = 0.17 ft}} = \frac{\text{Total}}{\text{Total}}$$

$$\frac{\text{n/a}}{\text{How many}} \times \frac{\text{Additional heating cable}}{\text{Additional heating cable}} = \frac{\text{Total}}{\text{Total}}$$

Total: 14.6 ft rounded up to 15 ft

Total heating cable length

$$\left(\frac{\text{300 ft}}{\text{Pipe length}} \times \frac{\text{1}}{\text{Number of heating cable runs}} \right) + \frac{\text{15 ft}}{\text{Additional cable for valves, pipe supports, and flanges}} = \frac{\text{315 ft}}{\text{Total heating cable length required}}$$

Step 4 Determine the electrical parameters

Determine maximum circuit length and number of circuits

See Table 9 and Table 10.

Total heating cable length required _____

Supply voltage: 120 V 208 V
 240 V 277 V

Circuit breaker size: 15 A 20 A
 30 A 40 A

Minimum start-up temperature _____

Maximum circuit length _____

_____ / _____ = _____
Total heating cable length required Maximum heating cable circuit length **Number of circuits**

Example:

Total heating cable length required 315 ft of 5XLE1-CR

Supply voltage: 120 V 208 V
 240 V 277 V

Circuit breaker size: 15 A 20 A
 30 A 40 A

Minimum start-up temperature -20°F

Maximum circuit length 193 ft

315 ft / 193 ft = 1.6 circuits, round up to 2
Total heating cable length required Maximum heating cable circuit length **Number of circuits**

Determine transformer load

See Table 11 and Table 12

_____ x _____ x _____ / 1000 = _____
Max A/ft at minimum start-up temperature Heating cable length Supply voltage **Transformer load (kW)**

Example:

0.124 A/ft x 315 ft x 120 V / 1000 = 4.7 kW
Max A/ft at minimum start-up temperature Heating cable length Supply voltage **Transformer load (kW)**

Step 5 Select the connection kits and accessories

See Table 13

Connection kits – Aboveground	Description	Quantity	Heating cable allowance
<input type="checkbox"/> RayClic-PC	Power connection and end seal	_____	_____
<input type="checkbox"/> RayClic-PS	Power splice and end seal	_____	_____
<input type="checkbox"/> RayClic-PT	Powered tee and end seal	_____	_____
<input type="checkbox"/> FTC-P	Power connection and end seal	_____	_____
<input type="checkbox"/> RayClic-S	Splice	_____	_____
<input type="checkbox"/> RayClic-T	Tee kit with end seal	_____	_____
<input type="checkbox"/> RayClic-X	Cross connection	_____	_____
<input type="checkbox"/> FTC-HST-PLUS	Low-profile splice/tee	_____	_____
<input type="checkbox"/> FTC-PSK	Pipe stand and power connection kit	_____	_____
<input type="checkbox"/> RayClic-LE	Lighted end seal	_____	_____
<input type="checkbox"/> RayClic-E	Extra end seal	_____	_____

Connection kits – Buried	Description	Quantity	Heating cable allowance
<input type="checkbox"/> RayClic-PC	Power connection and end seal	_____	_____
<input type="checkbox"/> FTC-XC	Power splice and end seal	_____	_____
<input type="checkbox"/> RayClic-LE	Lighted end seal	_____	_____
<input type="checkbox"/> RayClic-E	Extra end seal	_____	_____

Accessories – Aboveground and buried	Description	Quantity
<input type="checkbox"/> RayClic-SB-04	Pipe mounting bracket	_____
<input type="checkbox"/> RayClic-SB-02	Wall mounting bracket	_____
<input type="checkbox"/> ETL	“Electric-Traced” label	_____
<input type="checkbox"/> GT-66	Glass cloth adhesive tape	_____
<input type="checkbox"/> GS-54	Glass cloth adhesive tape	_____
<input type="checkbox"/> AT-180	Aluminum tape (for plastic pipes)	_____

Total heating cable allowance for connection kits

$$\text{_____} + \text{_____} = \text{_____}$$

Total heating cable length Total heating cable allowance for connection kits

Total heating cable length required

Step 6 Select the control system

See Table 18

**Thermostats,
controllers
and accessories**

	Description	Quantity
<input type="checkbox"/> 460	Single point heat tracing controller for pipe freeze protection	_____
<input type="checkbox"/> ECW-GF	Electronic thermostat with 25-ft sensor	_____
<input type="checkbox"/> ECW-GF-DP	Remote display panel for ECW-GF	_____
<input type="checkbox"/> C910-485	Microprocessor-based single-point heat-tracing controller	_____
<input type="checkbox"/> ACS-UIT3	ACS-30 user interface terminal	_____
<input type="checkbox"/> ACS-PCM2-5	ACS-30 power control panel	_____
<input type="checkbox"/> ProtoNode-RER	Multi-protocol gateway	_____
<input type="checkbox"/> RTD3CS	Resistance temperature device	_____
<input type="checkbox"/> RTD10CS	Resistance temperature device	_____
<input type="checkbox"/> RTD-200	Resistance temperature device	_____
<input type="checkbox"/> RTD50CS	Resistance temperature device	_____

Step 7 Select the power distribution

See Table 19

Power distribution	Description	Quantity
<input type="checkbox"/> HTPG	Heat-tracing power distribution panel for group control	_____

Step 8 Complete the Bill of Materials

Use the information recorded in this worksheet to complete the Bill of Materials.

Pipe Freeze Protection System Estimate Form

CHECK OUT TRACECALC PRO FOR BUILDINGS, OUR ONLINE PIPE TRACE DESIGN TOOL at <https://www.nVent.com/RAYCHEM/resources/design-tools/tracecalc-pro-buildings>

Email completed form to your Raychem Sales Rep for a complete Bill of Materials and quote!

1. Building Type:	<input type="checkbox"/> House	<input type="checkbox"/> Small shop / strip mall	<input type="checkbox"/> High-rise residential/ multi-use bldg.	<input type="checkbox"/> Commercial building
2. Line Name:				
3. Application:	<input type="checkbox"/> Water Lines	<input type="checkbox"/> Water Lines	<input type="checkbox"/> Water Lines	<input type="checkbox"/> Water Lines
	<input type="checkbox"/> Fire Protection Lines	<input type="checkbox"/> Fire Protection Lines	<input type="checkbox"/> Fire Protection Lines	<input type="checkbox"/> Fire Protection Lines
	<input type="checkbox"/> Greasy Waste Lines	<input type="checkbox"/> Greasy Waste Lines	<input type="checkbox"/> Greasy Waste Lines	<input type="checkbox"/> Greasy Waste Lines
	<input type="checkbox"/> Fuel Oil Lines	<input type="checkbox"/> Fuel Oil Lines	<input type="checkbox"/> Fuel Oil Lines	<input type="checkbox"/> Fuel Oil Lines
	<input type="checkbox"/> Other: _____	<input type="checkbox"/> Other: _____	<input type="checkbox"/> Other: _____	<input type="checkbox"/> Other: _____
4. Location:	<input type="checkbox"/> Above Ground <input type="checkbox"/> Below Ground	<input type="checkbox"/> Above Ground <input type="checkbox"/> Below Ground	<input type="checkbox"/> Above Ground <input type="checkbox"/> Below Ground	<input type="checkbox"/> Above Ground <input type="checkbox"/> Below Ground
5. Minimum Ambient:	<input type="checkbox"/> -20 <input type="checkbox"/> -10 : <input type="checkbox"/> 0 <input type="checkbox"/> +65 (indoor)	<input type="checkbox"/> -20 <input type="checkbox"/> -10 : <input type="checkbox"/> 0 <input type="checkbox"/> +65 (indoor)	<input type="checkbox"/> -20 <input type="checkbox"/> -10 : <input type="checkbox"/> 0 <input type="checkbox"/> +65 (indoor)	<input type="checkbox"/> -20 <input type="checkbox"/> -10 : <input type="checkbox"/> 0 <input type="checkbox"/> +65 (indoor)
6. Maintain Temp (°F):	_____ (°F)	_____ (°F)	_____ (°F)	_____ (°F)
7. Max Pipe Temp (°F):	<input type="checkbox"/> 150 <input type="checkbox"/> 185 <input type="checkbox"/> Other _____	<input type="checkbox"/> 150 <input type="checkbox"/> 185 <input type="checkbox"/> Other _____	<input type="checkbox"/> 150 <input type="checkbox"/> 185 <input type="checkbox"/> Other _____	<input type="checkbox"/> 150 <input type="checkbox"/> 185 <input type="checkbox"/> Other _____
8. Voltage:	<input type="checkbox"/> 120V <input type="checkbox"/> 208V <input type="checkbox"/> 240V <input type="checkbox"/> 277V	<input type="checkbox"/> 120V <input type="checkbox"/> 208V <input type="checkbox"/> 240V <input type="checkbox"/> 277V	<input type="checkbox"/> 120V <input type="checkbox"/> 208V <input type="checkbox"/> 240V <input type="checkbox"/> 277V	<input type="checkbox"/> 120V <input type="checkbox"/> 208V <input type="checkbox"/> 240V <input type="checkbox"/> 277V
9. Circuit Breaker Size:	<input type="checkbox"/> 15 A <input type="checkbox"/> 20 A <input type="checkbox"/> 30 A <input type="checkbox"/> 40 A	<input type="checkbox"/> 15 A <input type="checkbox"/> 20 A <input type="checkbox"/> 30 A <input type="checkbox"/> 40 A	<input type="checkbox"/> 15 A <input type="checkbox"/> 20 A <input type="checkbox"/> 30 A <input type="checkbox"/> 40 A	<input type="checkbox"/> 15 A <input type="checkbox"/> 20 A <input type="checkbox"/> 30 A <input type="checkbox"/> 40 A
10. Length of Pipe:	_____ ft	_____ ft	_____ ft	_____ ft
11. Pipe Diameter:	_____ in	_____ in	_____ in	_____ in
12. Pipe Material:	<input type="checkbox"/> Metal <input type="checkbox"/> Plastic	<input type="checkbox"/> Metal <input type="checkbox"/> Plastic	<input type="checkbox"/> Metal <input type="checkbox"/> Plastic	<input type="checkbox"/> Metal <input type="checkbox"/> Plastic
13. Number of Valves:				
14. Supports Outside Insulation?	<input type="checkbox"/> Yes <input type="checkbox"/> No	<input type="checkbox"/> Yes <input type="checkbox"/> No	<input type="checkbox"/> Yes <input type="checkbox"/> No	<input type="checkbox"/> Yes <input type="checkbox"/> No
15. Number of Flanges:				
16. Insulation Type:	<input type="checkbox"/> Fiberglass	<input type="checkbox"/> Fiberglass	<input type="checkbox"/> Fiberglass	<input type="checkbox"/> Fiberglass
	<input type="checkbox"/> CalSil	<input type="checkbox"/> CalSil	<input type="checkbox"/> CalSil	<input type="checkbox"/> CalSil
	<input type="checkbox"/> Cellular Glass	<input type="checkbox"/> Cellular Glass	<input type="checkbox"/> Cellular Glass	<input type="checkbox"/> Cellular Glass
	<input type="checkbox"/> Rigid Cellular Urethane	<input type="checkbox"/> Rigid Cellular Urethane	<input type="checkbox"/> Rigid Cellular Urethane	<input type="checkbox"/> Rigid Cellular Urethane
	<input type="checkbox"/> Foamed Elastomer	<input type="checkbox"/> Foamed Elastomer	<input type="checkbox"/> Foamed Elastomer	<input type="checkbox"/> Foamed Elastomer
	<input type="checkbox"/> Mineral Fiber Blanket	<input type="checkbox"/> Mineral Fiber Blanket	<input type="checkbox"/> Mineral Fiber Blanket	<input type="checkbox"/> Mineral Fiber Blanket
	<input type="checkbox"/> Expanded Perlite	<input type="checkbox"/> Expanded Perlite	<input type="checkbox"/> Expanded Perlite	<input type="checkbox"/> Expanded Perlite
17. Insulation Thickness:	_____ in	_____ in	_____ in	_____ in
18. Control On:	<input type="checkbox"/> Line Temperature	<input type="checkbox"/> Line Temperature	<input type="checkbox"/> Line Temperature	<input type="checkbox"/> Line Temperature
	<input type="checkbox"/> Ambient Temperature	<input type="checkbox"/> Ambient Temperature	<input type="checkbox"/> Ambient Temperature	<input type="checkbox"/> Ambient Temperature
19. Controls Provide GFPD?	<input type="checkbox"/> Yes <input type="checkbox"/> No	<input type="checkbox"/> Yes <input type="checkbox"/> No	<input type="checkbox"/> Yes <input type="checkbox"/> No	<input type="checkbox"/> Yes <input type="checkbox"/> No
20. # of Tee Connections Required?				
21. Notes:	BUSINESS CARD			
22. Customer name:				
Company:				
Phone:				
Email:				
Project name:				



North America

Tel +1.800.545.6258

info@chemelex.com



Raychem Tracer Pyrotenax Nuheat

©2025 Chemelex. All Chemelex marks and logos are owned or licensed by Chemelex GmbH or its affiliates. All other trademarks are the property of their respective owners. Chemelex reserves the right to change specifications without notice.

RAYCHEM-DG-H55838-XLTraceEdgePPFM-EN-2504-1