

Hot Water Temperature Maintenance – HWAT System

Raychem



This step-by-step design guide provides the tools necessary to design a Raychem Hot Water Temperature Maintenance System (HWAT). For additional information, contact your Chemelex representative or call (800) 545-6258. Also, visit our website at chemelex.com.

Table of Contents

INTRODUCTION	1
Typical Applications	2
Approvals and Code Compliance	2
Safety Guidelines	2
Ground Fault Protection	3
Scald Protection	3
Design Requirements	3
SYSTEM OVERVIEW	3
HWAT Electronic Controllers	4
HWAT Heating Cables	4
RayClic, FTC and HWT Connection Kits	5
DESIGN GUIDELINES	5
Before You Begin	6

INTRODUCTION

Raychem Hot Water Temperature Maintenance (HWAT) systems are a smart alternative to conventional recirculation systems for meeting modern Green energy and plumbing code that save water, energy and improve water quality.

HWAT systems consist of an electronic controller, self-regulating electric heating cables, pipe insulation and easy-to-install connection kits. The heating cables are attached to hot water supply pipes to compensate for heat loss and maintains water temperature to point of use, thus eliminating the need for return piping, balancing valves and associated equipment. When used in concert with conventional designs, it can optimize the overall efficiency of the hot water delivery system.

While our HWAT 208-277 V solutions have been delivering the benefits of Hot Water Temperature Maintenance immediate hot water at the tap, reduced water waste, and space and cost savings in mixed use high-rise buildings, schools and hotels for quite some time, our new HWAT 120 V system now offers the added value of a more residential / multi-family building-friendly “behind-the-meter” application.

When submetering is required by code, a conventional design would typically require a water heater installation for every unit in the building or a complex circulation system. A HWAT 120 V system, along with a central water heating unit, delivers a more economical solution that enables efficient and inexpensive metering and billing for each individual unit's hot water usage without complex system design and installations.

Additionally, our high quality HWAT systems improve water quality by meeting ASHRAE 188 Legionella control guidelines. HWAT systems are eligible for LEED points for both Energy Savings and Innovation in Design.

Typical Applications

The HWAT system is designed to be installed and operated in commercial and residential buildings. Table 1 shows typical HWAT applications, desired maintain temperatures when Raychem HWAT-P1 heating cable is used in conjunction with the Raychem HWAT-ECO-GF, or when Raychem HWAT-R2 heating cable is used in conjunction with the Raychem HWAT-ECO-GF or ACS-30 controllers.

Table 1 Typical HWAT Applications

Application	Desired maintain temperature
Hospitals, nursing homes	105°F (40°C)
Schools, prisons, some hospitals	115°F (45°C)
Offices, hotels, homes and apartments	125°F (50°C)
Kitchens, laundries	140°F (60°C)*

* with HWAT-R2 only.

This design guide covers standard HWAT applications which must meet the following conditions:

- Installed on copper or rigid plastic pipes
- Insulated in accordance with the insulation schedule shown in Table 6
- Powered at 120 V using HWAT-ECO-GF or at 208 - 277 V using the ACS-30 or HWAT-ECO-GF controller
- Operated indoors where the ambient temperature is relatively constant and between 60°F (15°C) and 80°F (27°C)

If your application does not meet the above conditions, contact your Raychem representative for custom design assistance.

Approvals and Code Compliance

The HWAT system components are c-UL-us Listed in nonhazardous locations.



HWAT-P1 and HWAT-R2 heating cables, RayClic, HWT and FTC-HST-PLUS connection kit and the HWAT-ECO-GF controller are c-UL-us Listed and the ACS-CRM and the ACS-CRMS controllers are c-UL-us certified (ACS-UIT3) to US and Canadian standards for use in non-hazardous locations. Refer to the specific product data sheets for details.

The HWAT system is designed in accordance with the following international and national codes:

- International Plumbing Code
- International Building Code
- International Energy Conservation Code
- National Standard Plumbing Code
- National Electrical Code
- Canadian Electrical Code
- ANSI/ASHRAE Standard 188-2018 - Legionellosis: Risk Management for Building Water Systems
- CIBSE TM13-2013 Minimising the Risk of Legionnaires Disease

Additionally, our HWAT solution has numerous state and local code approvals. Contact your Raychem representative for further information. Due to its potential to reduce energy usage and greenhouse gas emissions, HWAT solutions are eligible for LEED points.

Safety Guidelines

The safety and reliability of any heat-tracing system depends on the quality of the products selected and on proper design, installation, and maintenance. Incorrect design, handling, installation, or maintenance of any of the system components can cause overheating or overheating of the pipe or damage to the heating cable system and may result in system failure, electric shock, or fire. The guidelines and instructions contained in this guide are important. Follow them carefully to minimize these risks and to ensure that the HWAT system performs reliably.

Pay special attention to safety warnings identified as  **WARNING**.

Ground Fault Protection

To minimize the danger of fire from sustained electrical arcing if the heating cable is damaged or improperly installed, and to comply with Raychem requirements, agency certifications, and national electrical codes, ground fault equipment protection must be used on each heating cable branch circuit. Arcing may not be stopped by conventional circuit breakers. The HWAT-ECO-GF and ACS-30 controllers meet the electrical code requirements for ground fault equipment protection.

Scald Protection

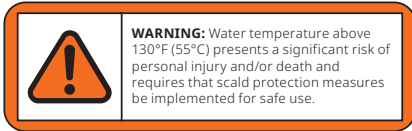

HWAT systems present an increased risk of scalding due to the high water temperature. Pay special attention to the scald warning to the left.

Design Requirements

To comply with warranty requirements, the design and installation of the HWAT system must be in accordance with this guide and the additional documents listed below:

- HWAT-ECO-GF Installation and Operations Manual (H60223)
- HWAT System Installation and Operations Manual (H57548)
- Rayclik Connection Kit Installation Instructions (H55388 and H55092)

Installation documents are shipped with the respective products and are also available on our website at chemelex.com.

SYSTEM OVERVIEW

A complete HWAT system includes one or more HWAT-ECO-GF or ACS-30 electronic controllers, HWAT-P1 or HWAT-R2 heating cable and Raychem RayClic connection kits. Fig. 1 illustrates a typical HWAT system. The key components of the system will be described in this section.

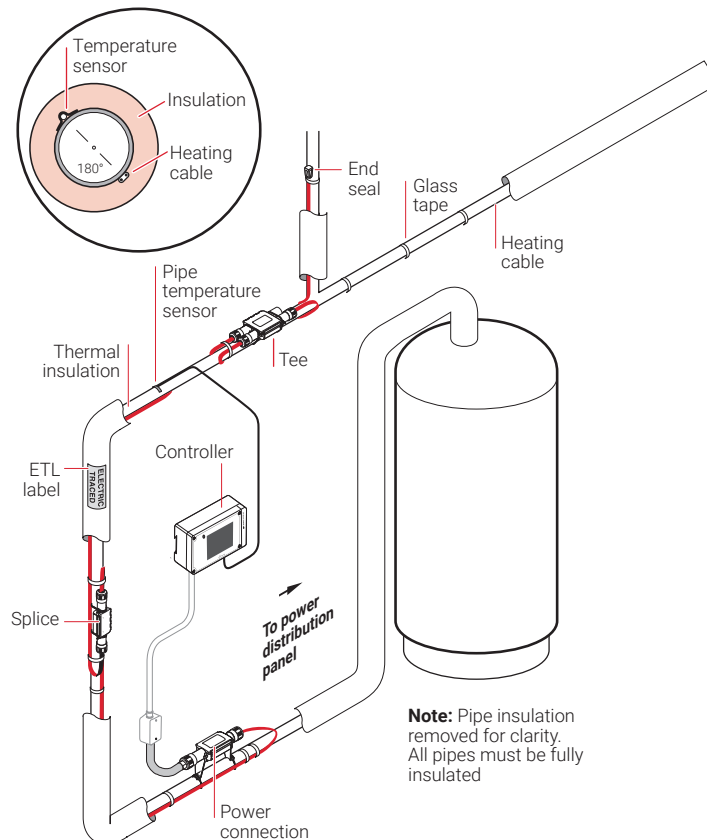

Fig. 1 Typical HWAT heating cable system

HWAT Electronic Controllers

The HWAT-ECO-GF electronic controller is designed for use with a single circuit of HWAT-P1 or HWAT-R2 self-regulating heating cable. For large hot water systems the ACS-30 distributed controller is available, refer to the ACS-30 data sheet (H58261) for more information. The HWAT-ECO-GF provides a variety of features and control options, listed below, for your hot water temperature maintenance system.

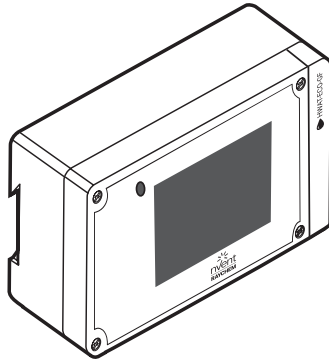

Fig. 2 HWAT-ECO-GF controller

- Equipment rated ground fault protection built-in
- Intuitive set-up and programming, includes a 5" inch color touch screen
- Flexible temperature control of hot water temperature maintenance systems
- Energy savings through an integrated function that lowers the maintain temperature during hours of low water consumption
- Heat-up cycle function that increases the water temperature of the hot water in the pipes
- Alarm relay to signal power, temperature or communication problems
- Hot water storage and pipe temperature monitoring with high and low temperature alarms and automatic system shut down
- Seven pre-defined building timer programs that can be customized by the user
- Program in advance in power-off mode by using external power bank/ charger and USB connection

HWAT Heating Cables

HWAT-P1 or HWAT-R2 self-regulating heating cables are installed on hot water supply pipes underneath standard pipe insulation. The heating cable adjusts its power output to reduce the effect of ambient temperature swings. The HWAT system provides continuous hot water temperature maintenance while eliminating the need for a recirculation system.

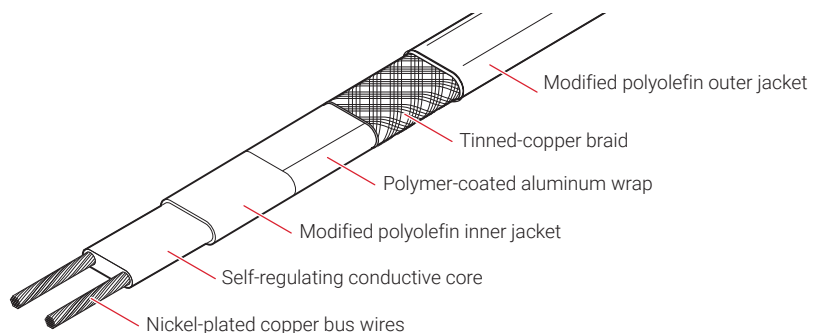

Fig. 3 HWAT heating cable

HWAT heating cables provide the following features:

- Adjust power output to reduce the variations in water temperature
- Can be cut to length, spliced, teed, and terminated in the field
- Designed for use with the HWAT-ECO-GF or ACS-30 controller

RayClic, FTC and HWT Connection Kits

The RayClic connection system is a simple, fast, and reliable set of connection kits developed for use with HWAT self-regulating heating cables. RayClic connection kits reduce installation time, lowering the total installed cost of the HWAT system. Raychem HWT-P and FTC-HST-PLUS heat shrink kits may also be used.

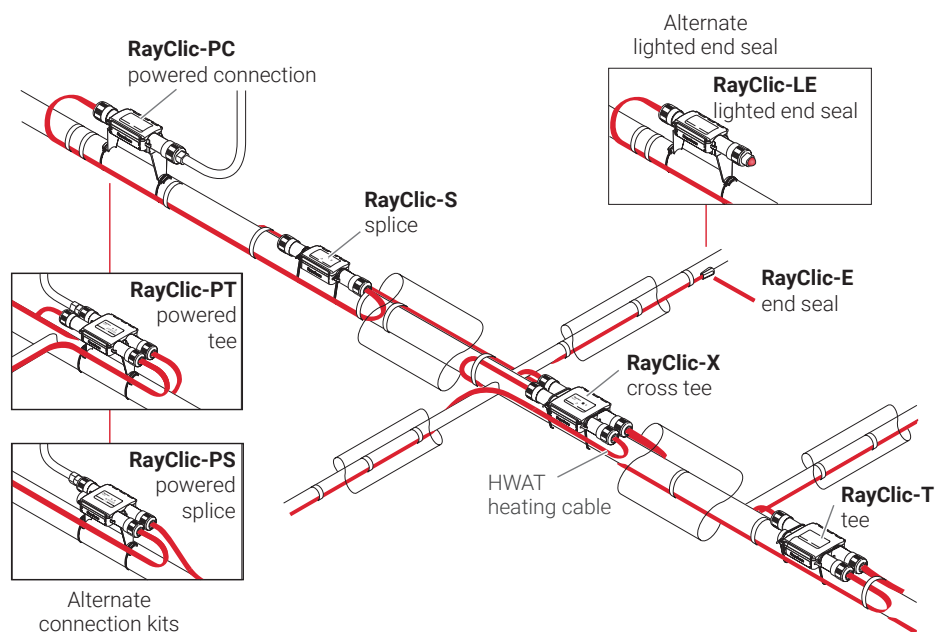

Fig. 4 RayClic connection kits

DESIGN GUIDELINES

This section describes the seven steps necessary to design an HWAT system:

- 1 Select the heating cable
- 2 Lay out the heating cable
- 3 Select connection kits and accessories
- 4 Finalize circuit length
- 5 Select control configurations
- 6 Select thermal insulation
- 7 Complete Bill of Materials

To assist you with the design, we will carry two design examples through this process. The example details are listed below each step in red.

Example 1

An elementary school where 115°F (46°C) is the desired maintain temperature and no heat-up cycle is required. Piping layout shows approximately 300 ft of pipe with two branches at the same location.

Example 2

A medium security prison where 115°F (46°C) is the desired maintain temperature and a 140°F (60°C) heat-up cycle is required. Piping layout shows approximately 700 ft of pipe with two branches at different locations.

Before You Begin

Before you begin designing your HWAT system, gather this necessary information:

- Desired maintain temperature
- Indoor ambient temperature
- Supply voltage
- Piping layout
- Total pipe length
- Pipe diameters

HWAT System Design
1. Select heating cable
2. Lay out the heating cable
3. Select connection kits and accessories
4. Finalize circuit length
5. Select control configuration
6. Select insulation
7. Complete Bill of Materials

Step 1 Select heating cable

Use Table 2 to select the appropriate system temperature setting. For more information on heat-up cycles, refer to the HWAT-ECO-GF Installation and Operations Manual (H60223) or ACS-30 Programming Guide (H58692).

Heating Cable Catalog Number

Before beginning, take a moment to understand the structure underlying heating cable catalog numbers. You will refer to this numbering convention throughout the product selection process. Your goal is to determine the catalog number for the product that best suits your needs.

Catalog Number: HWAT-P1 or R2

Voltage P1 = 120 V

R2 = 208, 240, 277 V

Fig. 5 Heating cable catalog number

Record the following information:

- Desired maintain temperature (°F/°C) _____
- Indoor ambient temperature (°F/°C) _____
- Supply voltage (V) _____
- Heat-up cycle (Yes/No) _____
- Temperature (°F/°C) _____

Example: Heating Cable Selection

Desired maintain temperature

Ambient temperature

Supply voltage

Heat-up cycle required

Heat-up cycle temperature

Example 1

115°F (46°C)

70°F (21°C)

208 Vac

No

n/a

Example 2

115°F (46°C)

70°F (21°C)

208 Vac

Yes

140°F (60°C)

Table 2 HWAT System Temperature Range

	HWAT-ECO-GF	ACS-30
Minimum maintain temperature	105°F (40°C)	100°F (38°C)
Maximum maintain temperature (HWAT-R2)	140°F (60°C)	150°F (66°C)
Maximum maintain temperature (HWAT-P1)	130°F (54°C)	
Heat-up cycle*	>140°F (60°C)	>150°F (66°C)

* For additional information on heat-up cycles, refer to the “Expanded HWAT-ECO-GF Electronic Controller Capabilities” section of the HWAT-ECO-GF Installation and Operations Manual (H60223).

Heating Cable Selection

Heating cable selected

Example

HWAT-R2

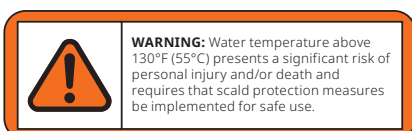

HWAT System Design
1. Select heating cable
2. Lay out the heating cable
3. Select connection kits and accessories
4. Finalize circuit length
5. Select control configuration
6. Select insulation
7. Complete Bill of Materials

Step 2 Lay out the heating cable

The piping layout of your building may require more than one HWAT circuit. To determine the number of circuits, group your piping by maintain temperature and location, a step that may require you to consult the plumbing and/or electrical engineer. Calculate the total length of pipe in each group, allowing one foot of heating cable for each foot of pipe. The length of heating cable in each group must not exceed the circuit lengths listed in Table 3.

In Step 4, you will calculate the additional cable required to install the connection kits. This will increase the total length of heating cable and may require the need for additional circuits.

Table 3 Maximum Circuit Length

Circuit breaker size (Amps)	Circuit Lengths	
	HWAT-P1 @120 V ft (m)	HWAT-R2 @208-277 V ft (m)
10	125 (38)	
15	195 (59)	250 (75)
20	276 (84)	330 (100)
30	395 (120)	500 (150)

Note: Assumes a minimum water temperature of 50°F (10°C) at startup

Example: Lay out Circuits

HWAT heating cable selected
 Length of pipe
 Number of circuits
 Circuit breaker size

Example

HWAT-R2
 700 ft
 2
 30 Amp

HWAT System Design
1. Select heating cable
2. Lay out the heating cable
3. Select connection kits and accessories
4. Finalize circuit length
5. Select control configuration
6. Select insulation
7. Complete Bill of Materials

Step 3 Select connection kits and accessories

HWAT systems are approved and warranted only as a complete system. The appropriate RayClic, FTC or HWT connection kits must be used. Use Table 4 to select the connection kits and accessories necessary for your HWAT system. Refer to the RayClic Connection System data sheet (H57545) and the FTC Heat Shrinkable Connection Kits Datasheet (H58159) in the Technical Data section for more information on the products.

The appropriate numbers of end seals are included with each connection kit.

Table 4 Connection Kits and Accessories

Catalog number	Description	Quantity required	No. of end seals included
RayClic-PC	Power connection kit	One -PC, -PS, -PT required per circuit	1
RayClic-PS	Powered splice kit	One -PC, -PS, -PT required per circuit	2
RayClic-PT	Powered tee kit	One -PC, -PS, -PT required per circuit	3
RayClic-S	Splice kit	As required*	0
RayClic-X	Cross kit	As required	2
RayClic-T	Tee kit	As required	1
RayClic-E	End seal kit	As required for spares	1
HWT-P	Heat shrink power connection kit	One required per circuit	1
FTC-HST-PLUS	Heat shrink splice or tee kit	As required	0
GT-66	Glass tape	1 roll per 50 ft of pipe	n/a
ETL	Electric traced tape	1 label per 10 ft of pipe	n/a

* To minimize cable waste, Raychem recommends that one RayClic-S be ordered for every 500 feet of cable.

Example: Select Connection Kits and Accessories
Piping layout determined that the following connection kits and accessories are required.

Example
2 RayClic-PC
2 RayClic-T
14 GT-66
70 ETL

HWAT System Design
1. Select heating cable
2. Lay out the heating cable
3. Select connection kits and accessories
4. Finalize circuit length
5. Select control configuration
6. Select insulation
7. Complete Bill of Materials

Step 4 Finalize circuit length

Additional cable is required for future access at each connection kit. Add the additional cable, as detailed in Table 5, to the estimated circuit lengths from Step 2. Confirm that the maximum lengths shown in Table 3 have not been exceeded. If your circuit lengths are greater than those shown, reconfigure your heating cable layout to allow for additional circuits.

Table 5 Additional Cable Required for Each Connection Kit

Connection kit name	No. of cable connections/kit	Cable length/ connection ft (m)	Total cable length (service loop) ft (m)
RayClic-PC	1	2.0 (0.6)	2.0 (0.6)
RayClic-S	2	1.0 (0.3)	2.0 (0.6)
RayClic-T	3	1.0 (0.3)	3.0 (0.9)
RayClic-X	4	1.0 (0.3)	4.0 (1.2)
RayClic-PS	2	1.5 (0.5)	3.0 (0.9)
RayClic-PT	3	1.3 (0.4)	4.0 (1.2)
RayClic-E	1	n/a	n/a
HWT-P	1	2.0 (0.6)	2.0 (0.6)
FTC-HST-PLUS	2 or 3	1.0 (0.3)	2.0 (0.6) for a splice 3.0 (0.9) for a tee

Example: Finalize Circuit Length

Example

	Circuit 1*	Circuit 2*
Length of heating cable per circuit	350 ft	350 ft
Additional cable required		
RayClic-PC	2 ft	2 ft
RayClic-T	3 ft	3 ft
RayClic-X	n/a	n/a
Total length of heating cable required	355 ft	355 ft

* In this example, the circuits were evenly divided. Equal circuit lengths are not required.

HWAT System Design
1. Select heating cable
2. Lay out the heating cable
3. Select connection kits and accessories
4. Finalize circuit length
5. Select control configuration
6. Select insulation
7. Complete Bill of Materials

Step 5 Select control configuration

For single circuit applications, choose the HWAT-ECO-GF controller.
For multi-circuit applications, choose the ACS-30 controller.

Example: Select Control Method

Example 1

Example 2

Type	Individual circuit	Multi-circuit
Number of circuits	1	up to 260
Controller	HWAT-ECO-GF	ACS-30

HWAT System Design
1. Select heating cable
2. Lay out the heating cable
3. Select connection kits and accessories
4. Finalize circuit length
5. Select control configuration
6. Select insulation
7. Complete Bill of Materials

Step 6 Select insulation

Select the size of thermal insulation from Table 6. You will need to know the length and diameter of each pipe used in your application.

For pipes 1¼ inches and smaller, use insulation that is oversized by ¼ inch to allow room for insulating over the heating cables. Table 6 specifies IPS (Iron Pipe Size) insulation, which has a greater inner diameter than CTS (Copper Tube Size) insulation.

For pipes 3 inches and larger, the thickness of insulation can either be equal to the pipe diameter with a single heating cable or $\frac{1}{3}$ the pipe diameter with two heating cables. For example, a 6 inch pipe with 6 inches of insulation and one run of heating cable is equivalent to a 6 inch pipe with 2 inches of insulation and two runs of heating cable.

Table 6 Fiberglass Insulation Selection

Copper pipe size (in)	IPS insulation size (in)	Insulation thickness (in)
$\frac{1}{2}$	$\frac{3}{4}$	$\frac{1}{2}$
$\frac{3}{4}$	1	1
1	$1\frac{1}{2}$	1
$1\frac{1}{4}$	$1\frac{1}{2}$	$1\frac{1}{2}$
$1\frac{1}{2}$	$1\frac{1}{2}$	$1\frac{1}{2}$
2	2	2
$2\frac{1}{2}$	$2\frac{1}{2}$	$2\frac{1}{2}$
3	3	3

Note: For pipes 3 inches and larger, the thickness of insulation can be equal to the pipe diameter with one run of heating cable or $\frac{1}{3}$ the pipe diameter with two runs of heating cable.

Example: Select Insulation

	Copper pipe size (in)	IPS insulation size (in)	Insulation thickness (in)
Example 1	$\frac{3}{4}$	1	1
	1	$1\frac{1}{4}$	1
	$1\frac{1}{2}$	$1\frac{1}{2}$	$1\frac{1}{2}$
Example 2	1	$1\frac{1}{4}$	1
	2	2	2
	$2\frac{1}{2}$	$2\frac{1}{2}$	$2\frac{1}{2}$

HWAT System Design
1. Select heating cable
2. Lay out the heating cable
3. Select connection kits and accessories
4. Finalize circuit length
5. Select control configuration
6. Select insulation
7. Complete Bill of Materials

Step 7 Complete bill of materials

You are now ready to compile a Bill of Materials. Using the design results, detail each item as shown in Table 7 below. Fig. 5 illustrates a complete typical HWAT system.

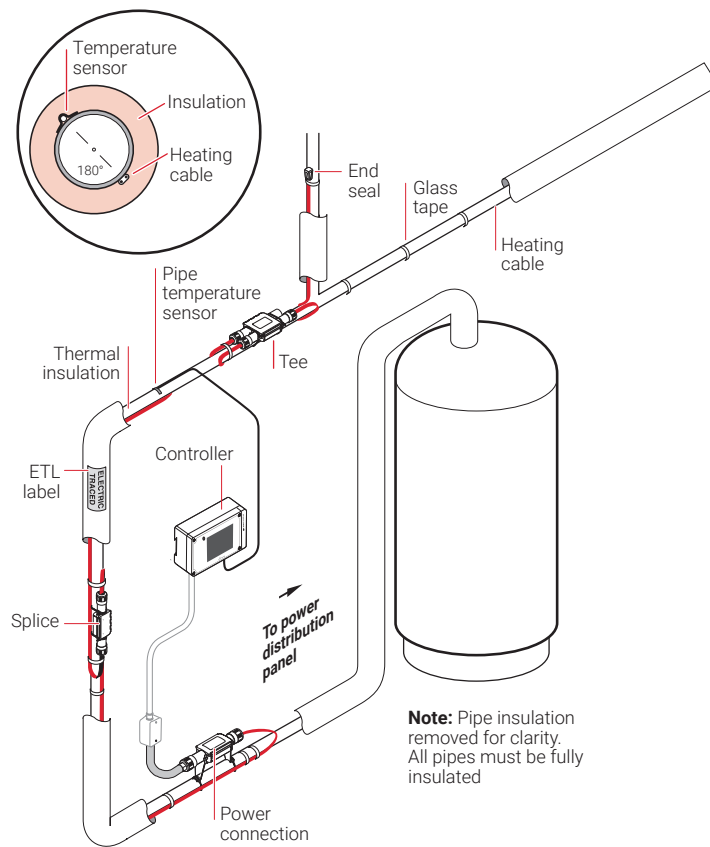

Fig. 6 Typical HWAT heating cable system

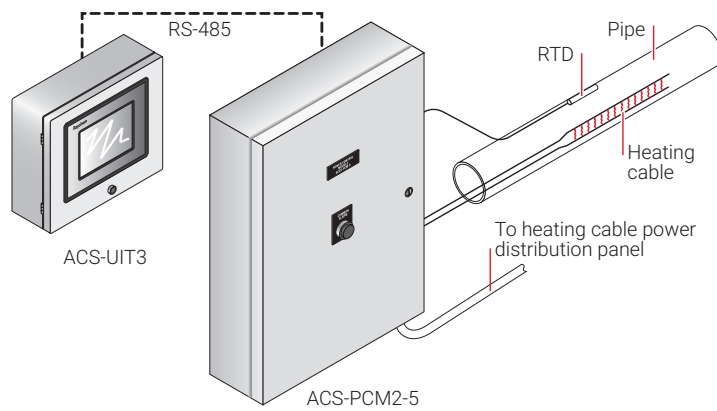

Fig. 7 Typical configuration for the ACS-30 system

Table 7 Bill of Materials (Example)

Description	Catalog number	Quantity
HWAT heating cable	HWAT-R2	706 ft
Power connection kit	RayClic-PC	2
Tee connection kit	RayClic-T	2
Controller	HWAT-ECO-GF	2
Attachment tape	GT-66	12 rolls
Labels	ETL	70

North America

Tel +1.800.545.6258

info@chemelex.com



Raychem Tracer Pyrotenax Nuheat

©2025 Chemelex. All Chemelex marks and logos are owned or licensed by Chemelex GmbH or its affiliates. All other trademarks are the property of their respective owners. Chemelex reserves the right to change specifications without notice.

RAYCHEM-DG-H57510-HWATHotWaterTempMaint-EN-2504