

Pyrotenax

Service Entrance QuickTerm Termination Kit

Installation Instructions for Terminating Single Conductor Copper Sheathed
Mineral Insulated Cable

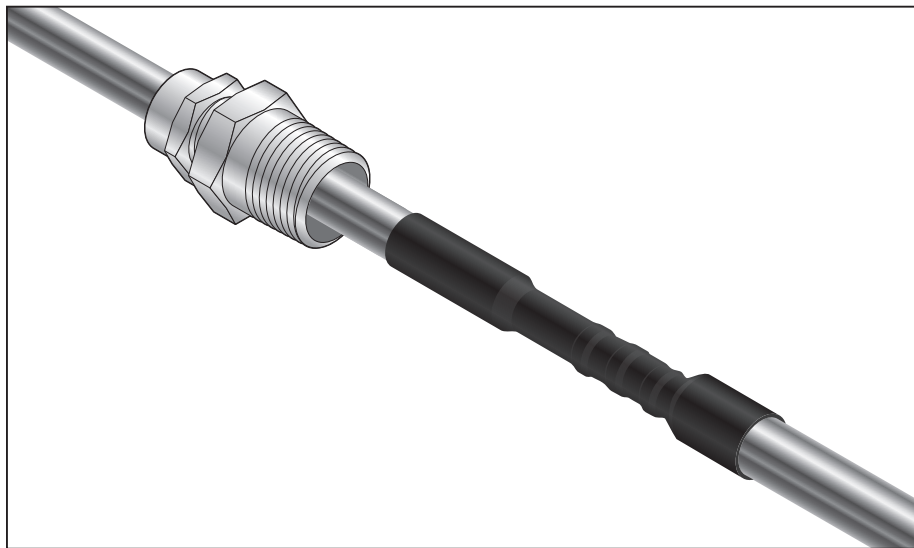

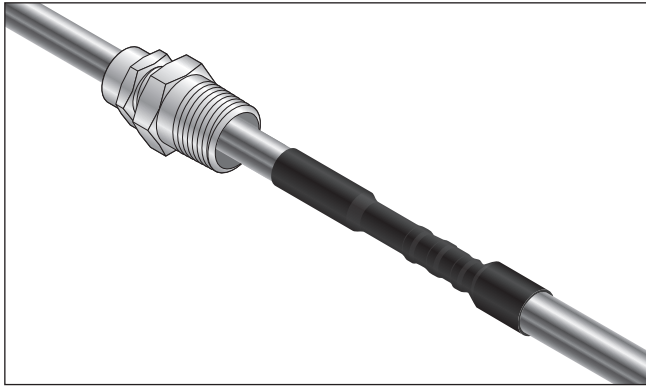

DESCRIPTION

This Pyrotenax Service Entrance QuickTerm termination kit is used to terminate 4/0, 250 kcmil, 350 kcmil and 500 kcmil single conductor Pyrotenax MI service entrance cables. A special tape is provided to seal the end of the MI cable and a compression connector is used to join the MI cable solid conductor to an equivalent size or larger "sized-up" flexible stranded conductor tail (supplied by installer). The sized-up tail is required when using the MI cable for its full free-air rated ampacity.

For technical support contact your local Chemelex representative or Chemelex at (800) 545-6258.

MATERIALS REQUIRED

- 90°C, 600 V insulated stranded copper conductor tails (THHN or equivalent – see Table on page 4 for conductor size required)

KIT CONTENTS

The Service Entrance QuickTerm termination kit contains sufficient material to terminate both ends of a cable.

Item	Qty	Description
A	2	Heat-shrinkable tubing
B	2	Brass gland connectors
C	2	Copper compression connectors
D	2	Self-amalgamating tape (roll)
E	1	Emery paper (roll)
F	2	Mastic sealing compound

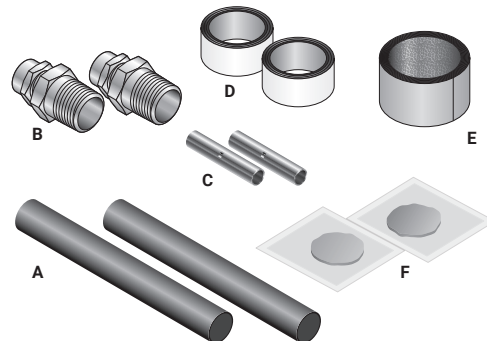

APPROVALS

Nonhazardous Locations



TOOLS REQUIRED

- Ratchet Type Stripping Tool
- Pyrotenax Handvise
- Hacksaw
- Flat file
- Scribe or pick
- Permanent marking pen
- Clean, dry cloth or rag
- Tape measure or ruler
- 500 Vdc megohmmeter
- Safety goggles and gloves
- Hydraulic crimping tool (see Table)
- Electric heat gun (recommended) or propane torch
- Oxy-acetylene or mapp gas torch (to dry out cable)
- Diagonal (side) cutter and tube cutter (if stripping cable sheath as shown in Appendix B)

⚠ WARNING:

This component is an electrical device that must be installed correctly to ensure proper operation and to prevent personal injury, shock or fire. Read these important warnings carefully and follow all installation instructions.

- When MI cable is stripped and terminated, cut metal edges can cause cuts and loose powder can cause eye irritation. To prevent injury, gloves and safety glasses must be worn when carrying out these operations.
- To prevent burns when drying out the cable (Appendix C), allow it to cool until warm to the touch before completing the remaining termination instructions.
- The Safety Data Sheet for the mastic sealing compound is available from Chemelex.

INSTALLATION

Note: The minimum installation temperature for this QuickTerm termination kit is 32°F (0°C).

- With a hacksaw, cut the end of the MI cable square and file the end smooth.
- Identify the compression connector supplied with the termination kit. Locate the corresponding compression connector part number in the Table below and mark the MI cable sheath at length "L" shown in the Table. This is the length of sheath to remove.
- Place a second mark 1-½ in (3.8 cm) behind the first mark. The sheath will only be stripped back to the first mark exposing the solid conductor. The second mark from the end is used to position the Handvise for final stripping.
- For details on using the Ratchet Type Stripping Tool, refer to instruction H57842 supplied with the tool. An alternate method of stripping the cable sheath using a tubing cutter and side cutters is shown in Appendix B.

1

Using Ratchet Type Stripping Tool

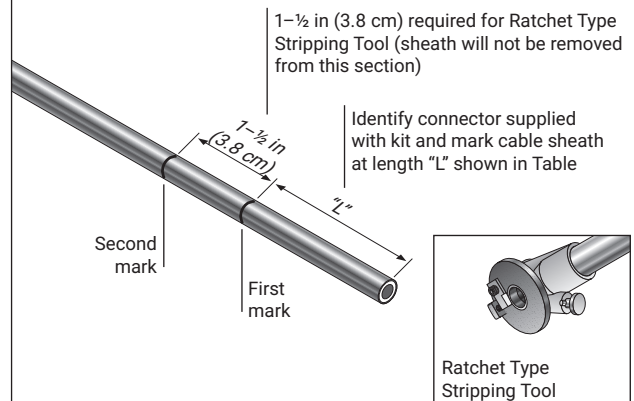

2

- Place the brass gland connector on to the cable. The gland connector is made up of three parts: the gland nut, the compression sleeve and the gland body. It should be placed on to the cable with all three pieces assembled.

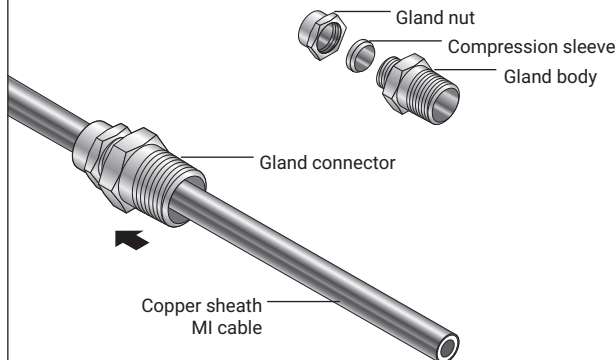

3

- Grip the cable with the Handvise.
- Using the sheath stripping tool (Ratchet Type Stripping Tool shown), begin stripping the copper sheath back towards the first mark.

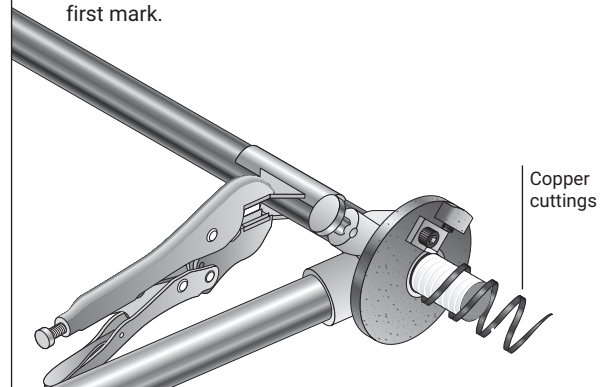

Guide for end-to-end splicing of 90°C, 600 volt insulated stranded copper conductor tail to MI solid copper conductor

Cable reference number	MI cable size (AWG/kcmil)	Compression connector identification	90°C insulated stranded conductor required	Length "L" of MI sheath to strip	MI sheath stripping tool	Compression tools (see Note)	Number of crimps				
							IlSCO Die Color	IlSCO Die Number	Solid end	Stranded end	
Pyrotex System 1850 SE											
1/4/0-684	4/0	A8204	500 kcmil	3-¼ in (8.3 cm)	Sheathmaster Stripping Tool	Die Type	Brown	ILD-15	1	1	
1/250-746	250	A8203	500 kcmil	3-¼ in (8.3 cm)	Sheathmaster Stripping Tool	Die Type	Brown	ILD-15	1	1	
		A8213	600 kcmil	3-¼ in (8.3 cm)	Sheathmaster Stripping Tool	Die Type	Green	ILD-15	1	1	
1/350-834	350	A8179	500 kcmil	3-¼ in (8.3 cm)	Ratchet Type Stripping Tool	Die Type	Brown	ILD-15	2	2	
		A8189	750 kcmil	3-½ in (8.9 cm)	Ratchet Type Stripping Tool	Die Type	Black	ILD-17	3	3	
1/500-1000	500	A8147	500 kcmil	3-¾ in (8.6 cm)	Ratchet Type Stripping Tool	Die Type	Brown	ILD-15	2	2	
		A8181	750 kcmil	3-½ in (8.9 cm)	Ratchet Type Stripping Tool	Die Type	Black	ILD-17	3	3	

Note: 1. The compression connectors must be crimped using IlSCO ILC-12, ILC-12-N, ILC-12H, ILC-12H-N, ILC-14 or ILC-14H die type hydraulic tools.

4

- For final stripping, grip the cable with the Handvise at the second mark. When the stripping tool touches the edge of the Handvise, it will stop and make a clean cut on the cable sheath at the first mark. At this point, the correct length of solid conductor will have been exposed.

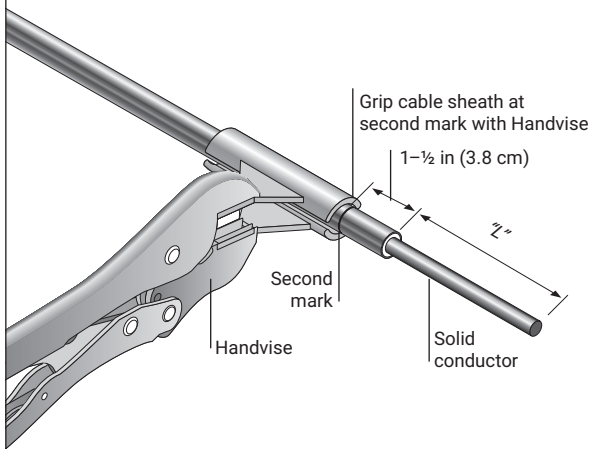

5

- Clean the conductor with a clean, dry rag or cloth to remove loose powder from the conductor. Next, polish all around entire length of solid conductor and 2 in (5.0 cm) of sheath behind the conductor with emery paper to achieve a clean surface.
- Visually inspect the magnesium oxide insulation at the face of the cable for traces of copper filings and burrs and if present, gently remove with a pick.

Note: When cleaning the conductor with the rag and emery paper and if it is necessary to use a pick to remove copper filings from the face of the cable, do not remove more powder from the face of the cable than is necessary.

Note: Do not blow out copper filings that may be present in the MgO powder as this can introduce moisture into the end of the cable, resulting in decreased insulation resistance.

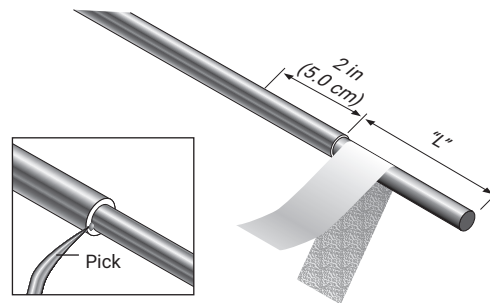

6

- Using a 500 Vdc megohmmeter, check the insulation resistance (IR) of the cable between conductor and sheath to ensure it is free of grounds and shorts. The other cable end must also be free of grounds and shorts and must be sealed. See Appendix A for detailed test procedure and IR test criteria. Once IR readings are satisfactory, immediately complete Step 7 & 8 to seal the end of the MI cable. A delay will cause the IR to drop and the cable must be retested prior to sealing the end.

Note: If neither cable end has yet been terminated and IR readings are low, dry out both ends following the procedure in Appendix C or cut off shorted end and re-test. Apply a temporary moisture resistant seal, such as hot melt glue or adhesive lined heat-shrinkable tubing, to opposite cable end to prevent moisture absorption.

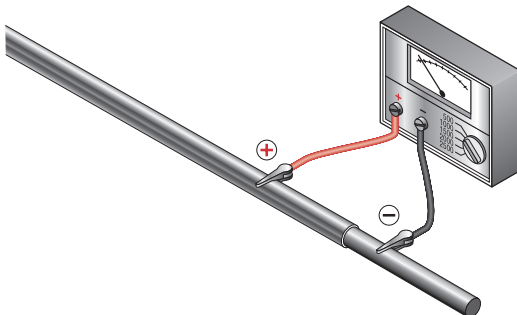

7

- While wearing protective gloves, carefully mold the mastic sealing compound around the conductor, pressing it firmly while kneading it into place. Avoid getting oil on fingers or cable to ensure the tape in Step 8 adheres properly.

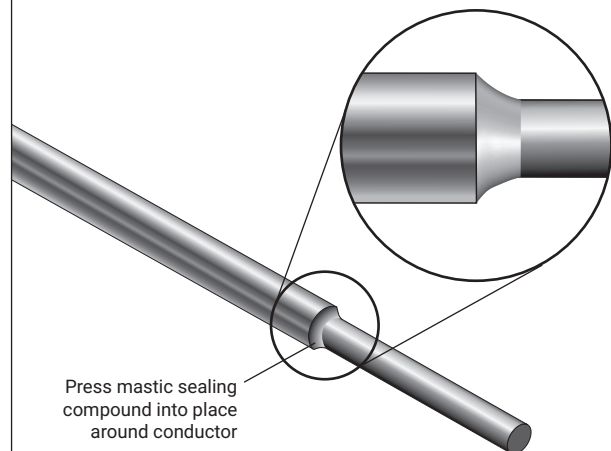

8

- Apply tape seal to MI cable and ensure that you tape along the sheath and solid conductor as shown. Stretch the sealing tape to about 3 times its length (or about half of the original width), just short of the breaking point.
- Beginning on the cable sheath and using half-laps, wind the tape under tension, taping 1-½ in to 1-¾ in (3.8 cm to 4.5 cm) along the cable sheath and 1-½ in to 1-¾ in (3.8 cm to 4.5 cm) along the solid conductor.
- Reverse the direction and wind the tape back along the conductor and 1-½ in to 1-¾ in (3.8 cm to 4.5 cm) of cable sheath (over the tape just applied).
- Finally, reverse the direction once again and wind the tape back along the sheath and 1-½ in to 1-¾ in (3.8 cm to 4.5 cm) of conductor (again, over the tape just applied). Maintain half-laps and stretch tape as described above while winding along sheath and conductor. Tear off excess tape. The tape will bond to itself in a short time.

Important: Use only the self-amalgamating tape supplied by Chemelex to seal the end of the MI cable.

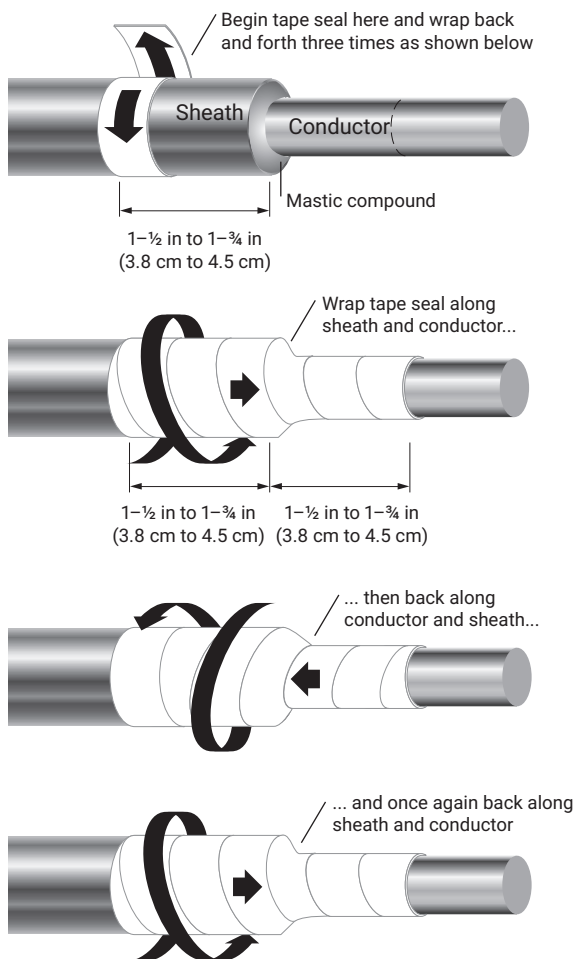

9

- Once the tape seal is completed to this point, the end of the MI cable should appear as shown.

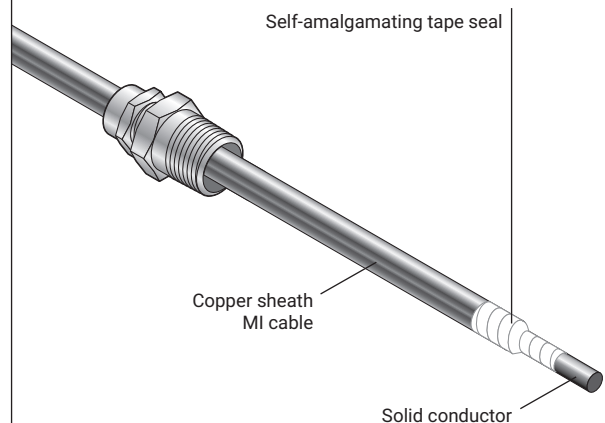

10

- Strip just enough insulation from the appropriate AWG size, 90°C, 600 V stranded conductor tail to fit to the center-stop in the compression connector (see Table on page 3 for size of stranded conductor tail required). Insert the stranded conductor tail into the larger end of the compression connector (if both ends are the same size, the stranded conductor tail may be inserted into either end).
- Crimp the connector to the stranded conductor tail using the required number of crimps and an approved crimping tool (see Table on page 3 for details). **Where multiple crimps are required, make the outside crimp first and work towards the middle of the connector.**

Important: See Table on page 3 for approved crimping tools to be used with the QuickTerm compression connectors.

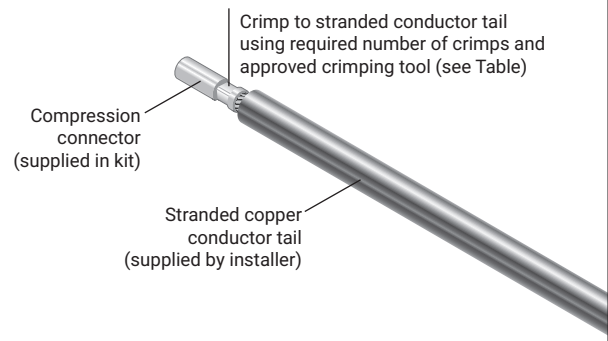

11

- Place the adhesive lined heat shrinkable tubing (supplied with termination kit) on to the MI cable.
- Insert the solid MI conductor into the smaller end of the compression connector (if both ends were the same AWG size in the previous step, insert the MI solid conductor into the other end).
- Crimp the connector to the solid conductor using the required number of crimps and an approved crimping tool (see Table on page 3 for details). **Where multiple crimps are required, make the outside crimp first and work towards the middle of the connector.** The solid conductor to stranded conductor joint should appear as shown.

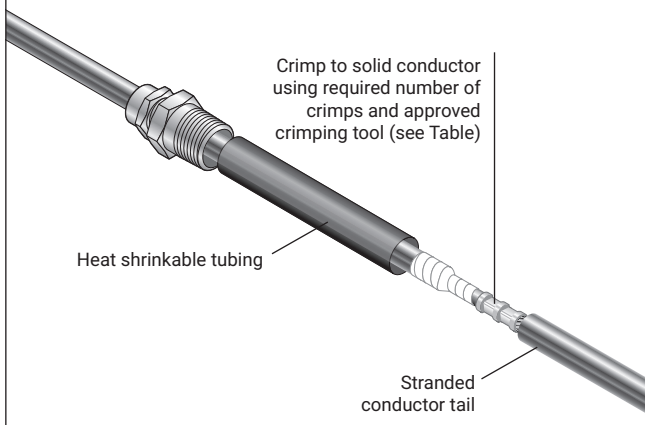

12

- Prior to sealing the entire joint with the heat-shrinkable tubing, remove all sharp edges from the compression connector with a flat file.
- Place the heat-shrinkable tubing over the joint so that it completely covers the tape seal and compression connector and overlaps the MI cable sheath and the insulation on the stranded conductor tail by at least ½ in (1.3 cm).
- Shrink in place with a heat gun or propane torch being careful not to damage the heat-shrinkable tubing. When using a propane torch, take care not to burn the heat-shrinkable tubing.

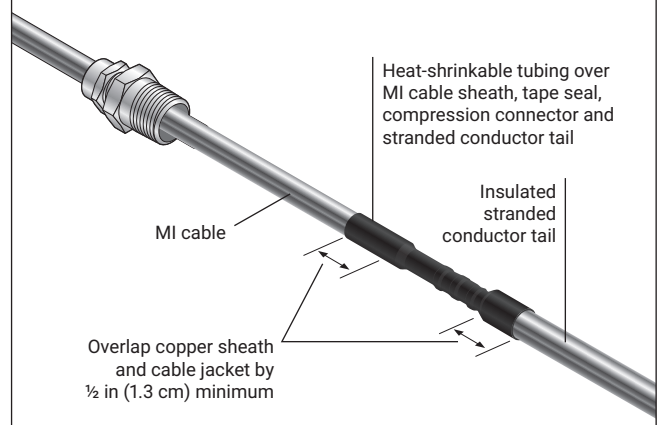

13

- Check IR once more from stranded conductor tail to MI cable sheath to ensure that the cable has been properly sealed and IR is satisfactory. If the IR does not meet the values under Test Criteria in Appendix A, the termination must be removed and remade after completing the "drying out" procedure outlined in Appendix C.

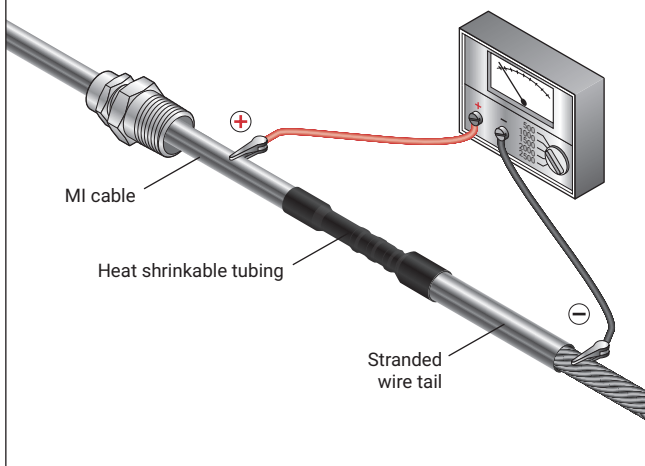

Appendix A: Insulation Resistance (IR) Test

Test Equipment

500 Vdc Megohmmeter

IR Testing

IR testing is conducted using a megohmmeter and tests the integrity of the cable between the conductor and the copper sheath.

Test Criteria

When received:

- Check cable on reel. Note that ends may need to be prepared to allow insulation resistance (IR) readings to be taken. IR readings must not be less than 200 MΩ under any conditions.

After installing termination kit:

- In a warm, dry environment, IR readings should be 200 MΩ or higher.
- In an outdoor environment or indoors in wet or humid conditions, IR readings should all be above 100 MΩ.
- Similar cables exposed to similar conditions should all have IR readings in the same general range. Where a large difference in readings is encountered, high readings can be accepted; low readings (below 100 MΩ) should be checked as described below.

Note: Under some installation conditions it may not be possible to obtain IR readings above 100 MΩ. If IR readings are between 25 MΩ and 100 MΩ, wait 24 hours and recheck the IR using the same equipment. If the IR reading has not decreased, the termination is good – a constant low IR reading can result from moisture entrained in the cable while making a good seal; this moisture will not increase. If the IR reading has decreased, the cable must be re-terminated – a low IR reading can result from a poorly made seal which will allow continuing moisture ingress, requiring that the termination be redone.

If the IR reading is less than 25 MΩ, the cable must be re-terminated following the “drying out” procedure in Appendix C.

Test Procedure

1. Set megohmmeter test voltage at 0 Vdc or off.
2. Connect the positive (+) (earth) lead to the cable sheath.
3. Connect the negative (-) (line) lead to the conductor.
4. Turn on the megohmmeter and set the voltage to 500 Vdc; apply the voltage for one minute. Meter needle should stop moving. Rapid deflection indicates a short. Note the insulation resistance value. It should correspond to the values shown under Test Criteria.
5. Turn off the megohmmeter.

WARNING: The MI cable can store a large electrical charge after the insulation resistance test is performed. To prevent personal injury from electrical shock, fully discharge the cable prior to disconnecting the megohmmeter. Many meters will discharge automatically. However, it may be necessary to short the cable leads. Contact your supervisor or the instrument manufacturer to verify the safest practice.

6. Testing is complete. If the megohmmeter does not self-discharge, discharge phase connection to ground with a suitable grounding rod. Disconnect the megohmmeter.

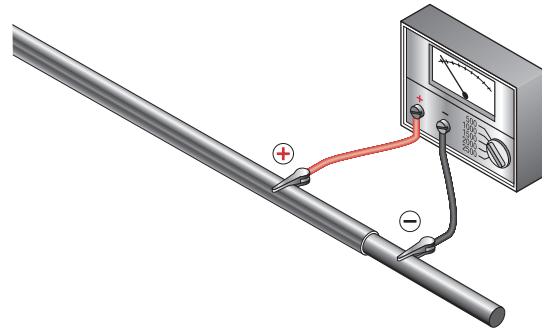

Appendix B: Stripping Copper Sheath MI Cable

Using diagonal cutters

Measure, from cable end, length of cable sheath to strip and mark sheath with marking pen. Use a tube cutter to score around the sheath at the mark. This will cause the sheath to peel away at the score providing a smooth end when the sheath is stripped. The correct depth of score is half the thickness of the sheath.

Do not cut completely through the cable sheath as this will cause the sheath to curve inwards toward the conductor(s).

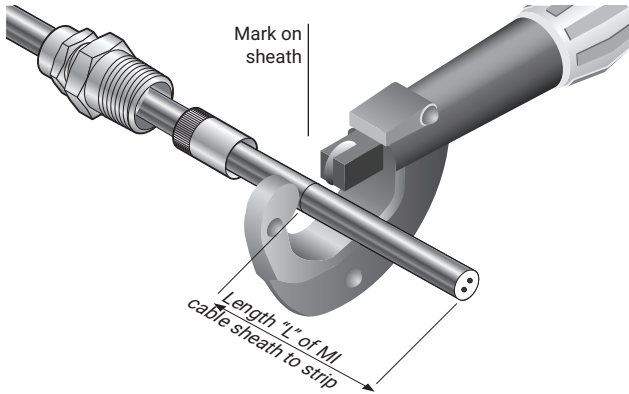

Hold the cable with the Handvise behind the score on the sheath. Grip the edge of the sheath between the jaws of the side cutters and twist clockwise (twist counter-clockwise if lefthanded), then take a new grip and rotate through a small angle.

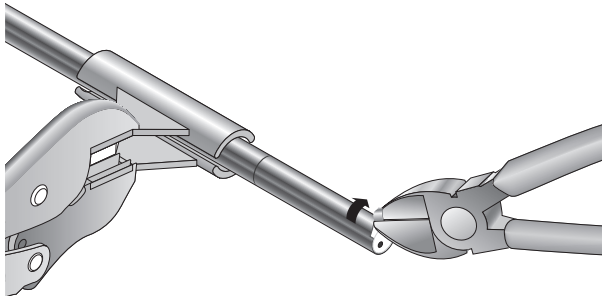

Continue this motion in a series of short "rips", keeping the side cutters at about 45° to the line of the cable, removing sheath spirally. Remove compacted powder insulation to expose conductors.

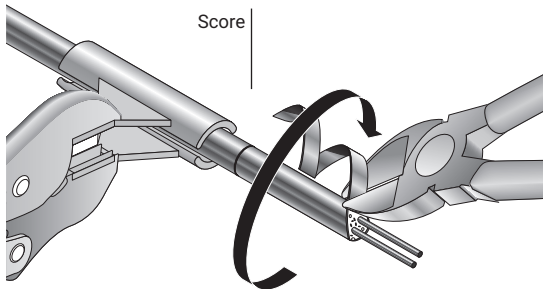

Continue removing the sheath to the score mark. When about to break into the score, bring side cutters to right angle with cable. Finish off with point of side cutters held parallel to the cable. The sheath will peel away leaving a clean cut when the score mark is reached.

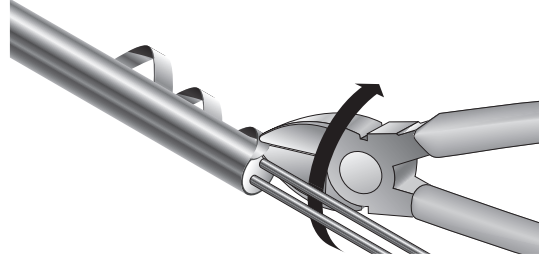

The cable sheath is correctly stripped, with the sheath flared slightly outwards, as shown in (a).

In (b) the sheath is neither flared outwards nor beveled inwards, but is acceptable.

Ensure that the sheath is not curved or beveled inward as shown in (c). This will occur if the score made with the tube cutter is too deep. In this case, remove a further ¼ in (6 mm) of sheath. Cable is now ready to be sealed.

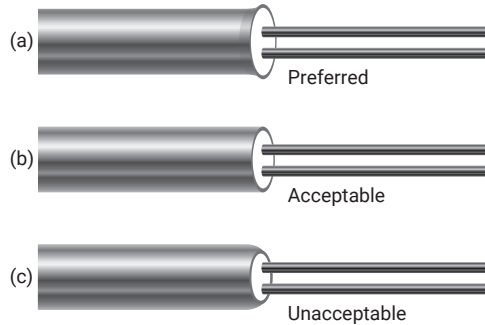

Appendix C: Improving Insulation Resistance

To maintain the high performance of MI cable, the cable must be properly stored and the ends must remain sealed.

Damaged terminations or heat-shrinkable end caps that are damaged, missing, or removed will cause the magnesium oxide insulation (white powder) to absorb moisture, resulting in low IR readings. The cable must be "heated out" to remove the moisture and bring the IR back to an acceptable level. Drying out the MI cable to remove any moisture will normally be unnecessary providing the termination seal is completed within a few minutes of removing the sheath.

If moisture is found in the cable when checking IR, it may be removed using one of the following methods:

1. If excess cable is available, 6 to 12 in (15 to 30 cm) of cable may be removed from the end before sealing the cable.
2. Apply heat to the cable following the procedure below.

 **Note:** Moisture will not normally penetrate more than 12 in (30 cm) into the cable.

If moisture is detected in the cable, use an oxy-acetylene or mapp gas torch with a large flame and "heat out" the cable beginning 12 in (30 cm) back from the end. Gradually move the flame toward and past the cable end. Copper sheathed cables should be heated to a bluish-gray color. Take care not to overheat any one area of the cable sheath as this could damage the cable.

Use a short sweeping motion of the torch and heat about 2 in (5 cm) of cable at a time, repeating 4 to 5 times.

Move the flame towards the cable end as shown. Do not sweep the flame in the opposite direction as this will drive the moisture into the cable.

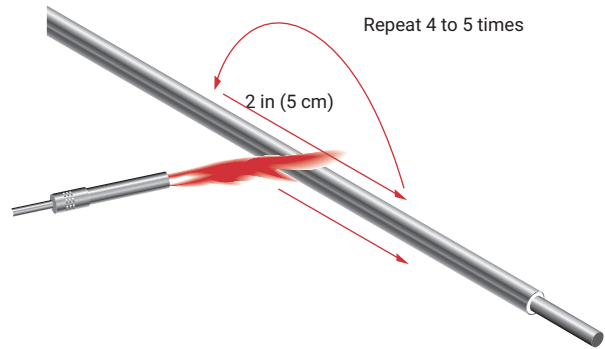

Gradually move the flame toward the end while maintaining the short sweeping motion of the torch. If you heat toward the cable end too quickly you may skip over the moisture and drive it further back into the cable.

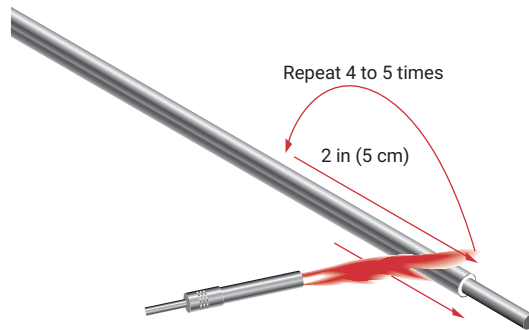

It may be necessary to repeat the above procedure several times to completely remove all moisture from the cable. Allow the cable to cool before repeating. On completion, check IR with a 500-V insulation tester (Megohmmeter).

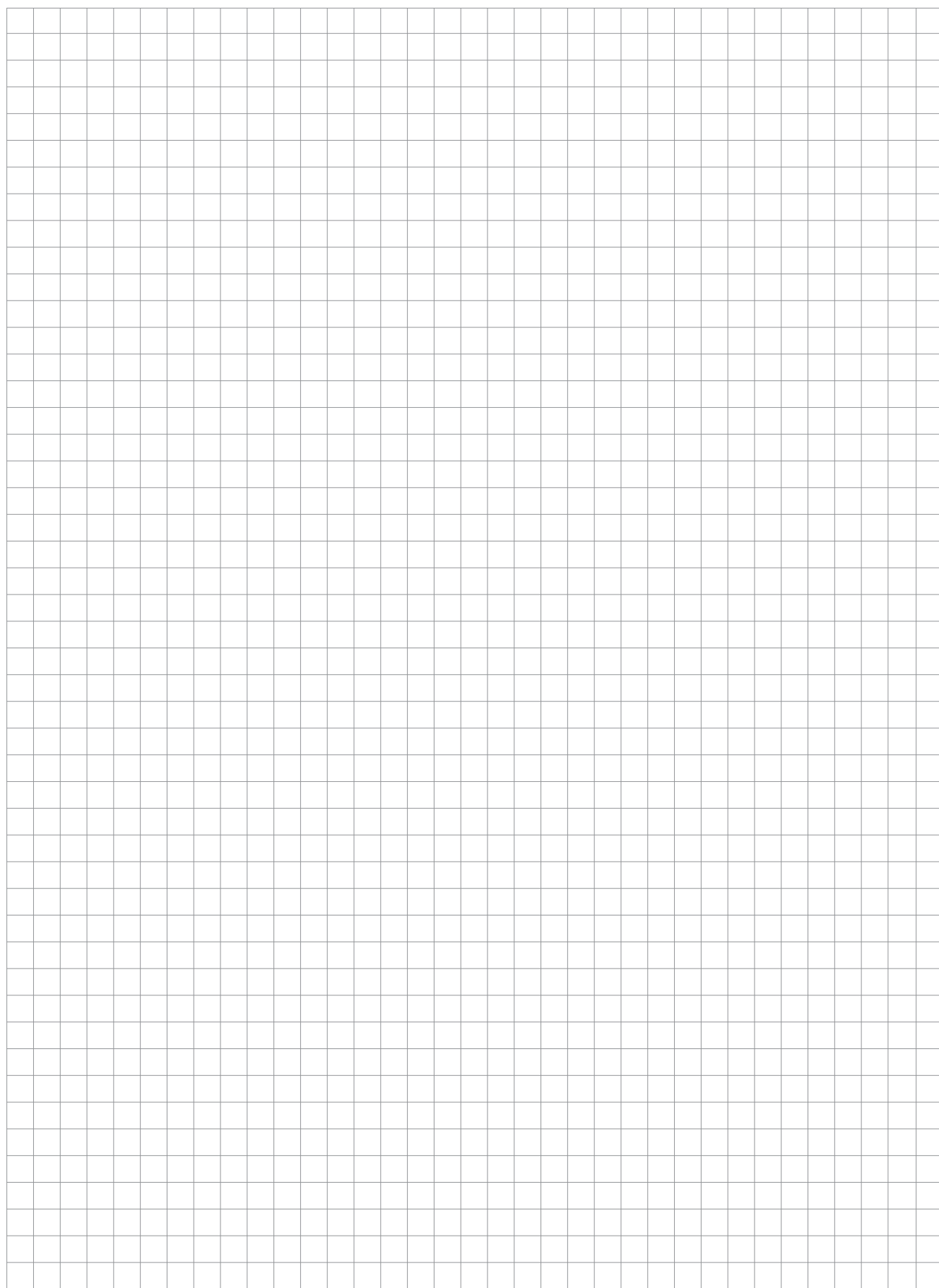

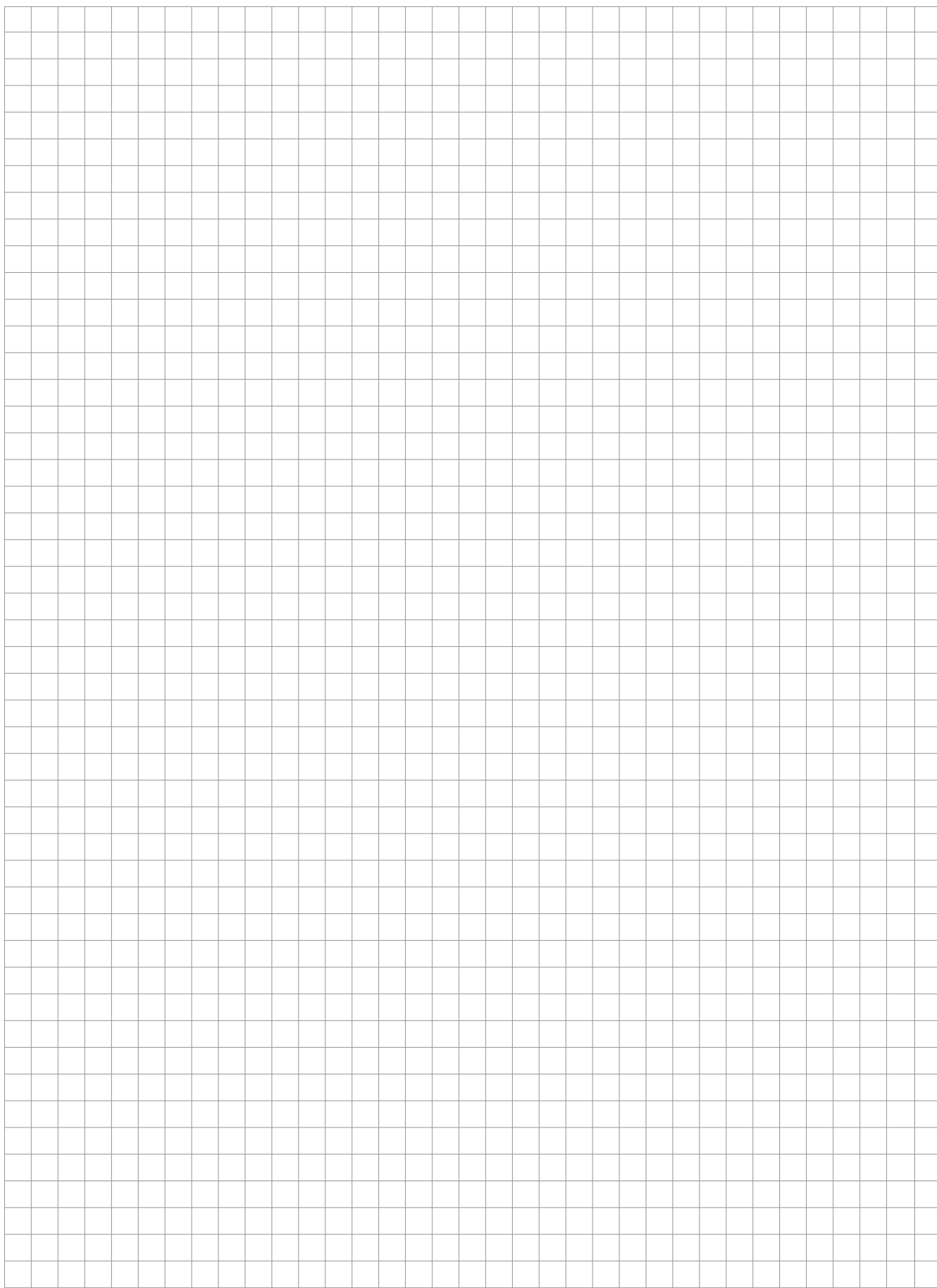

North America

Tel +1 800 545 6258
info@chemelex.com

Latin America

Tel +1 713 868 4800
info@chemelex.com

Europe, Middle East, Africa, India

Tel +32 16 213 511
Fax +32 16 213 604
info@chemelex.com

Asia Pacific

Tel +86 21 2412 1688
infoAPAC@chemelex.com

chemelex
excellence is everything

Raychem

Tracer

Pyrotenax

Nuheat