

# *Pyrotenax*

## Power Stripper Tool

User Instructions for Powered Tool Used to Strip Copper Sheathed Mineral Insulated Wiring Cables

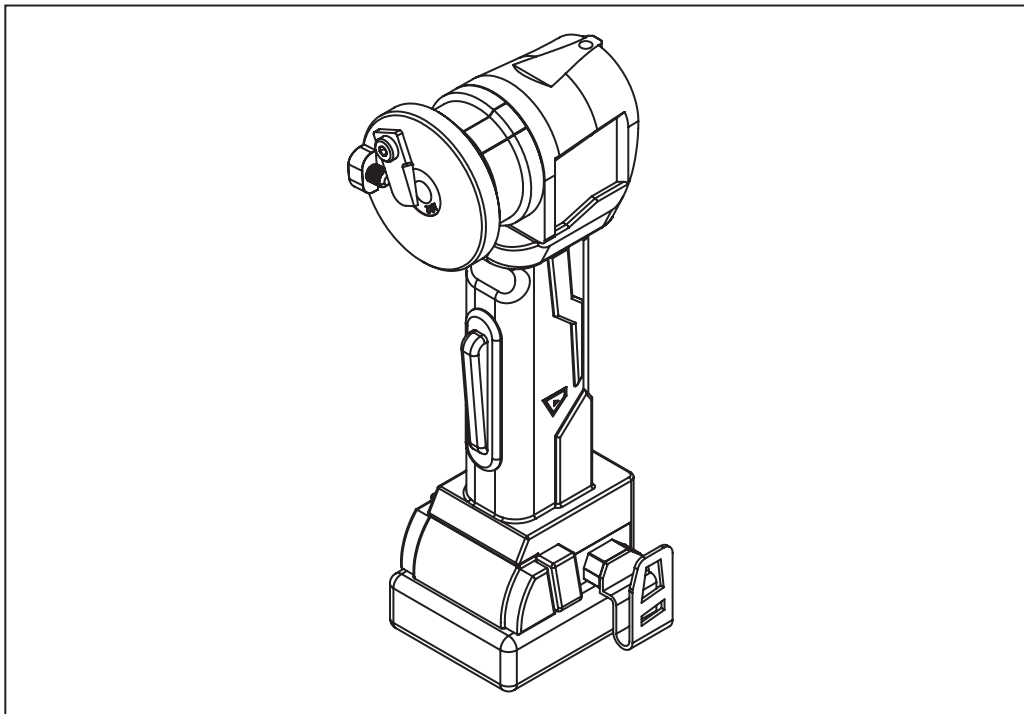

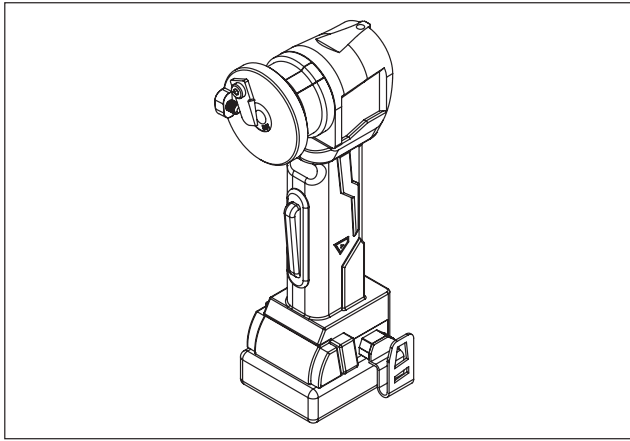

## KIT CONTENTS

Item	Qty	Description
A	1	Power Stripper Tool Adapter Head (includes 1 blade)
B	15	Head Adapter Bushing – Standard cables ranging 0.198 to 0.543 in
C	4	Head Adapter Bushing – Twisted shielded cables (incl. 2 special “shield” bushings)
D	4	Guide Bushing – For all cables ranging from 0.215 to 0.543 in
E	1	3/32 in Allen Key
F	1	5/32 in Allen Key
G	1	Spare blade for Power Stripper Tool Adapter Head

## DESCRIPTION

The Pyrotenax Power Stripper Tool kit is designed for stripping of Pyrotenax copper sheath Mineral Insulated (MI) cables with diameters of 0.543 in and smaller. The Power Stripper head must be inserted into a Milwaukee M18™ Cable stripper #2935-20 or Milwaukee M18™ Cable Stripper (base power tool) included in Milwaukee Kits #2935CU-21, #2935AL-21 or 2935X-21 (not supplied).

A power stripper tool head, head adapter bushing, and power tool guide bushing are required for cable stripping.

## TOOLS AND ACCESSORIES REQUIRED

- Power Tool: Milwaukee M18™ Cable stripper # 2935-20 or M18™ Cable Stripper Kit #2935-CU-21, #2935AL-21 or 2935X-21 (not supplied)
- Pyrotenax Hand Vise (Part No. HANDVISE) (available from Chemelex)
- Safety glasses and protective gloves

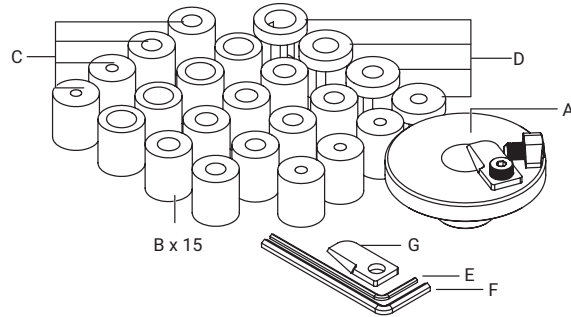

## WARNING:

- Do not use the Pyrotenax Power Stripper Tool with any non-compatible strippers. Use only Pyrotenax power stripper tool head, cable head adapter bushings, and power tool guide bushings. Use of non-approved parts presents a significant risk of personal injury and/or death.
- Do not use the Power Stripper Tool with any cable other than approved Pyrotenax MI cable with correct head, adapter

bushing. Use of the Pyrotenax stripping tool with non-approved cables presents a significant risk of personal injury and/or death.

- To avoid injury and prevent the tool from rotating when not desired, always remove battery pack or lock the power tool before working on it or setting up stripper head assembly.
- Wear safety glasses and protective gloves to avoid injury.

- Follow all warnings, instructions and recommendations associated with the use of the Milwaukee M18™ Cable stripper # 2935-20 or M18™ Cable Stripper Kit #2935CU-21, #2935AL-21, #2935X-21 and battery. Refer to Milwaukee user manuals for detailed warnings.



## IMPORTANT:

- To prevent moisture from entering the cable and to maintain the high performance of MI cable, the cable ends must be sealed as soon as the cable has been cut to length and the sheath removed as the magnesium oxide insulation will absorb moisture, lowering the insulation resistance.
- Do not use the Power Stripper Tool head to straighten the cable.

## REPLACEMENT PARTS

PWBLADE	Replacement blade for Power Stripper
PWBXS	Replacement head adapter and guide bushings for Power Stripper: 0.198 to 0.280 in cables
PWBS	Replacement head adapter and guide bushings for Power Stripper: 0.281 to 0.371 in cables
PWBM	Replacement head adapter and guide bushings for Power Stripper: 0.372 to 0.465 in cables
PWBL	Replacement head adapter and guide bushings for Power Stripper: 0.466 to 0.543 in cables
PWBTS	Replacement head adapter and guide bushings for Power Stripper: Twisted Shielded cables

## PREPARING THE POWER TOOL TO RECEIVE THE MI POWER STRIPPER HEAD

1

- Unscrew the top screw from the power tool head and remove the square nut it is screwed into.

 **Warning:** Always remove the battery pack before adding or removing parts.

 **Note:** The top screw threads into a square nut. Ensure the nut is taken out and set aside for later use.

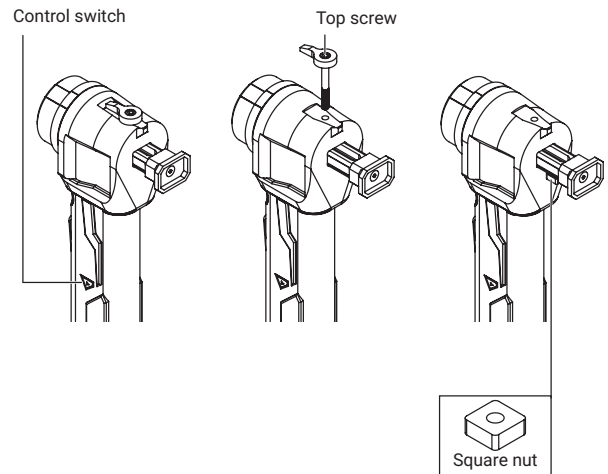

2

- Using the provided 3/32 in Allen Key, unscrew the bolt at the back of the depth gauge and remove the black handle.

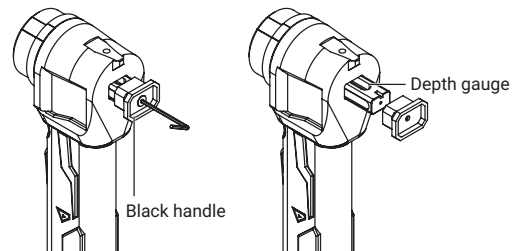

3

- Push the depth gauge out of the power tool head and set all removed parts aside. These parts will be needed to restore the power tool's original functionality.
- The power tool is now ready to accept the MI power stripper head.

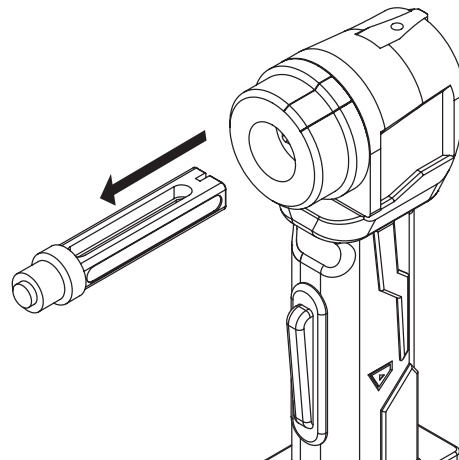

## USING THE MI POWER STRIPPER

4

- Insert the power stripper adapter head into tool, while depressing the bushing latch on the power tool.
- Release the latch and rotate head until the power tool pin clicks into place. Tug on stripper head to ensure it is secure.

 **Warning:** Always remove the battery pack before adding or removing parts or while first adjusting the blade position. If the blade needs adjustment in the middle of stripping a cable sheath, instead of removing the battery, the control switch may be pushed to its "locked" position (center position) to prevent the tool from rotating.

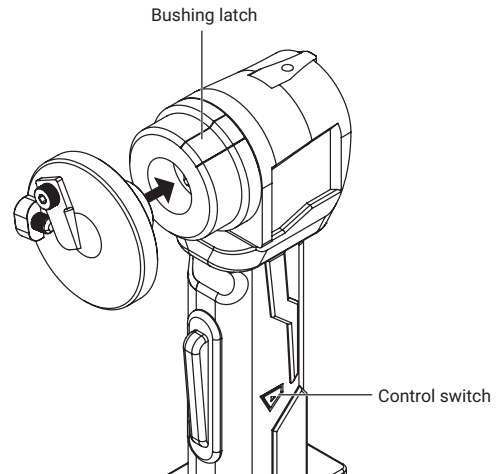

5

- Choose correct head adapter bushing and guide bushing according to the cable sheath diameter to be removed. See Table 1 for details.
- Inspect head adapter bushing before proceeding to next step. It is recommended to replace the bushing if large dents or wear (deeper than 1/8 in or 3mm) are observed as it may prevent proper stripping. See Table 1 for required part number.

 **Note:** When removing the shield from Twisted Shielded cables (TS cables), use the special bushings provided (230S and 198S). They have an extra shoulder allowing the exact length of exposed shield required for the completion of the TS cable termination to be left on the cable.

 **Note:** Failure to choose the correct head adapter bushing may prevent proper stripping and cause damage to the cable and tool.

Head adapter bushing  
(or head bushing)  
(standard):

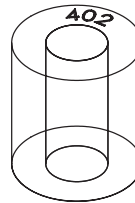

Head adapter bushing  
(or head bushing) for  
TS cables:

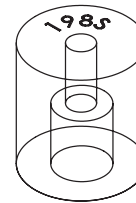

Guide bushing:

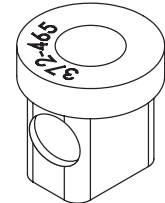

Table 1: Bushing List (all cables)

Bushing Group (Part Number)	Cable Reference	Head Bushing Size (Marking)	Guide Bushing Size (Marking)
PWBL	7/12-543	543	466-543
	1/1/0-512	512	
	2/8-512		
	1/1/-496	496	
	7/14-496		
	3/12-480	480	
PWBM	4/14-465	465	372-465
	4/12-465		
	1/3-449	449	
	1/2-449		
	2/10-449		
	7/16-449		
	1/4-402	402	
	2/12-402		
	4/16-387	387	
	3/14-387		
PWBS	2/14-371	371	281-371
	3/16-355	355	
	1/6-340	340	
	2/16-340		
	1/8-298	298	
PWBXS	1/10-277	277	198-280
	2/16-246T	246	
	2/18-215T	215	
PWBTS	2/16-364TS	364	281-371
	2/16-364TS Shield	230S*	
	2/18-324TS	324	
	2/18-324TS Shield	198S*	

\* These bushings are designed to accept and strip the shield inside the TS cables after the outer sheath has been removed. They have an extra shoulder inside and are marked with the shield outside diameter and an S (example: 230S).

6

- Insert the selected guide bushing to the back of the base tool.
- Using the blade locking screw, loosen the blade and temporarily rotate it out of way (use the provided 5/32 in Allen Key if necessary).
- Insert the selected head bushing into the tool adapter head, chamfered end first.
- Bring the blade back to its original position.

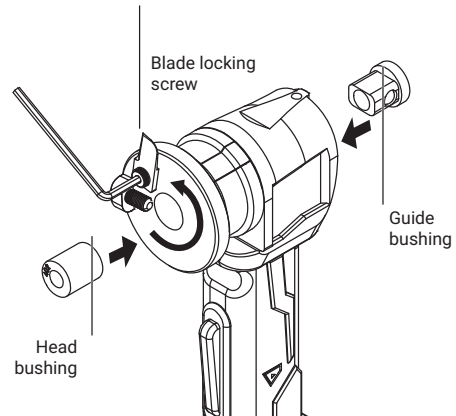

7

- Prior to stripping, the cable should be straight and end should be cut square. File the cable end lightly to remove burrs and to facilitate cable entry into nylon bushing.

 **Note:** For larger cables, sliding the tool over the approximate cable length to be stripped prior to setting up the blade will verify that the cable is sufficiently straight. Straighten the cable if necessary. This will prevent the tool from slowing down (or stopping) due to a cable bend while stripping.

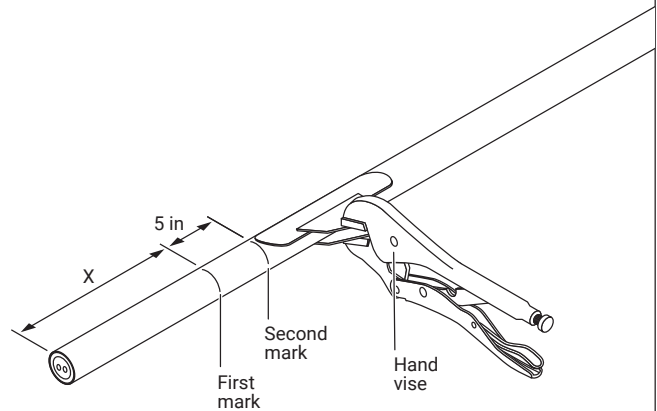

- Measure the length of sheath to be stripped (refer to installation instruction supplied with the termination kit) and mark sheath. Place a second mark 5 in (12.7 cm) from this first mark.
- Grip the cable firmly with the hand vise at the second mark so as to make the final cut against a stop which is square to the cable.

8

- Slip the power stripper assembly over the cable, guide bushing end first until the cable is flush with the blade.

 **Note:** The cable may not slide through the cable bushing at first due to the copper sharp edges. Rotating the power tool back and forth or pressing the power trigger lightly (after unlocking the power tool) to start the tool rotation will guide the cable in. Stop the rotation as soon as the cable is in. Lock the tool again by pressing the control switch.

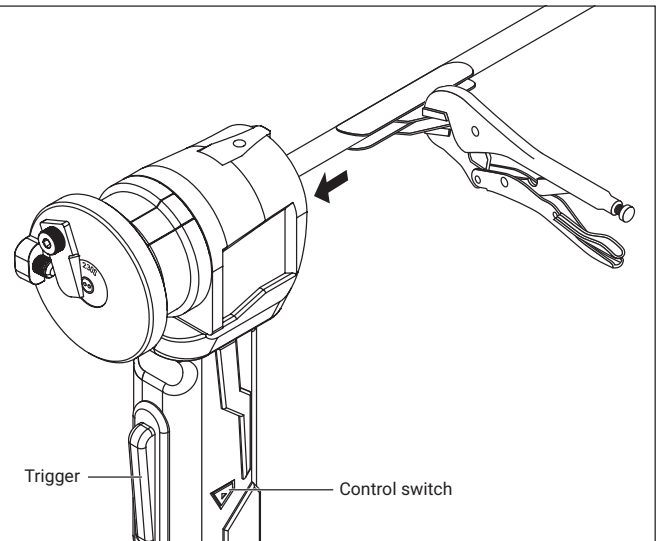

- Loosen the blade locking screw and using the provided 5/32 in Allen Key, adjust the blade position with the blade adjustment screw. Set the cutting edge near the conductor without covering it.
- Hand tighten the blade locking screw.



**Note:** Proper blade adjustment from the beginning ensures the cable stripper will cut all the way through the sheath without scoring or damaging the conductors. A blade that is seated too far from the conductors will not cut the sheath fully, while a blade that is seated too close or covers the conductors may cause damage.

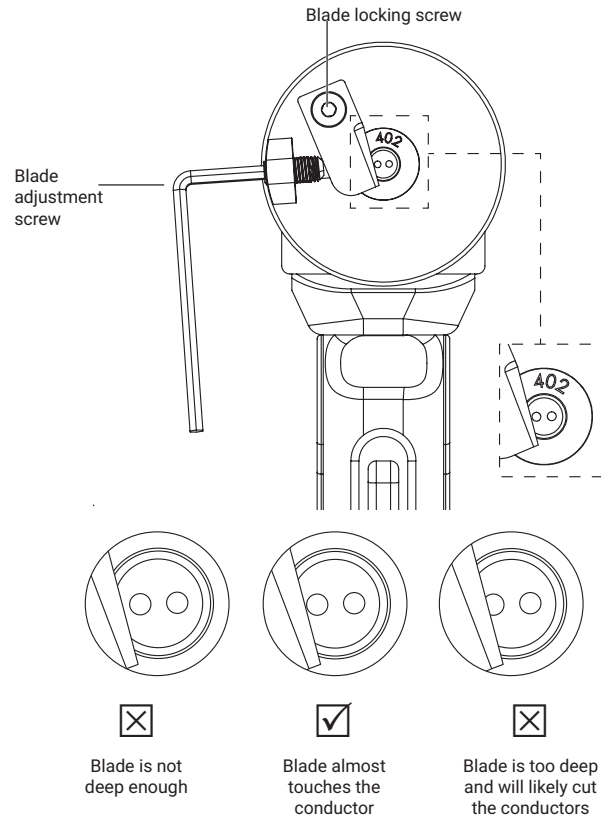

- Unlock the power tool so it can rotate.
- Gently apply pressure towards the cable being stripped while pressing lightly on the power tool trigger in order to start cutting the sheath.
- Verify the tool adapter head rotates clockwise when facing it. Press the control switch to reverse direction if required.
- After a couple of turns:
  1. Verify that the sheath is fully cut: a copper cutting (swarf) should appear.
  2. Verify also that the blade is not cutting or scoring the conductor. If the sheath is not fully cut or the conductor is scored, immediately stop the tool. See the trouble shooting guide for instructions on how to easily correct the problem.
- If stripping looks proper, fully press the trigger while still applying gentle pressure towards the cable being stripped.

**Warning:** Wear gloves when handling or touching copper cutting to avoid cuts.

**Warning:** Hold the power tool handle in place as it will want to rotate when the trigger is pressed, like a drill.

**Warning:** Blade and copper cutting may become warm when stripping continuous long lengths of cables. Always wear gloves.

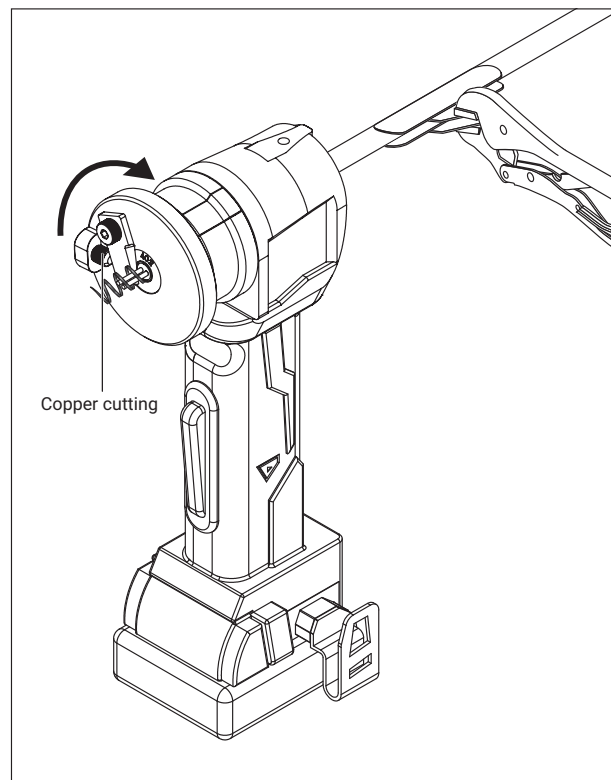

11

- When the stripping tool touches the edge of the hand vise, it will stop moving and make a clean cut on the cable sheath. Release the trigger. The copper cutting can now be removed and the stripping tool withdrawn.
- Cable is now ready for sealing. Refer to the termination kit's instruction manual for more details.

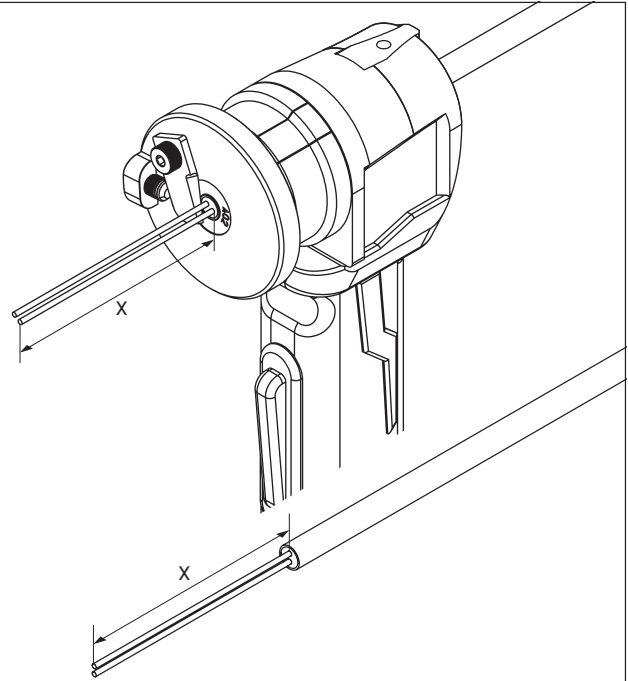

## STRIPPING CABLES 0.465 IN DIAMETER AND UNDER

12

The copper cutting produced while stripping will droop when stripping cables smaller than 0.512 in diameter and/or conductors smaller than 10 AWG.

- If using the hand vise, it is recommended to stop every 4 to 6 in (10 to 15 cm) to cut and remove the copper cutting so it does not get caught against the conductors. This will be required when stripping longer lengths of conductors (24 or 36 in; 61 or 92 cm) and/or when reaching the last inches of cable (adjacent to the hand vise).
- Alternatively, a second pair of hands can guide the cuttings away from the tool so it does not get tangled.

 **Warning:** Wear gloves when handling or touching copper cutting to avoid cuts.

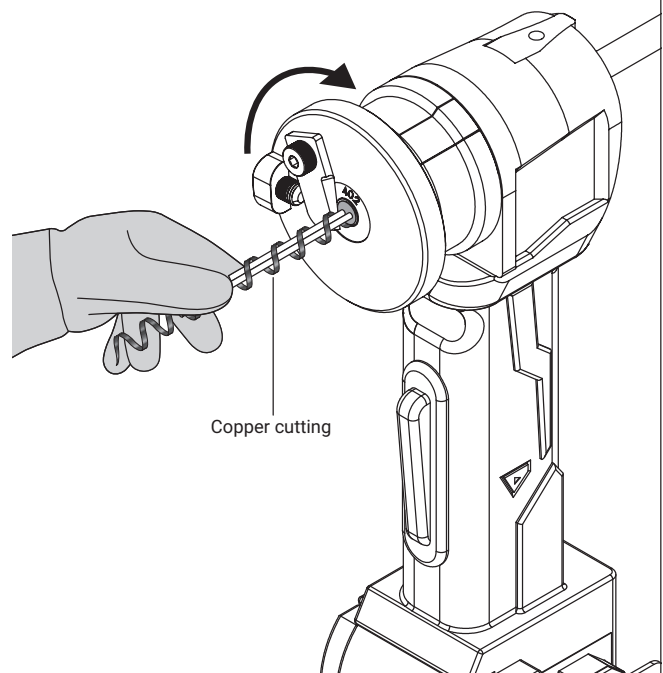

## STRIPPING CABLES 0.324 IN DIAMETER AND UNDER

13

- The copper cutting produced while stripping cables smaller than 0.324 in (8.23 mm) diameter will droop and get tangled with the exposed conductors.
- If using a hand vise, it is recommended to stop every 2 to 4 in (5 to 10 cm) (or as required) to cut and remove the copper cutting before it gets too tangled.
- Alternatively, a second pair of hands may guide the cutting so it does not get tangled: applying a gentle pull on the copper cutting will prevent it from getting tangled and help it slide along the conductors. Care should be taken not to pull too hard as the cutting will grab the conductors instead of sliding against them.

 **Warning:** Wear gloves when handling or touching copper cutting to avoid cuts.

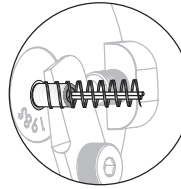

If not removing copper cutting often, it will get tangled and stripping will eventually be stopped.

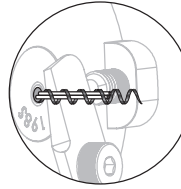

Gently pulling on the copper cutting and cutting it off regularly will ensure the cutting does not get tangled with the conductors.

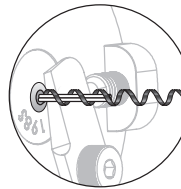

If pulling too hard on copper cutting, it will tighten on the conductors and get stuck, making it hard to remove.

## STRIPPING TWISTED SHIELDED (TS) CABLES

14

### STRIPPING THE OUTER SHEATH

- Proceed with stripping the outer sheath following the procedures as described above Steps 5 to 11. Position the blade as if the shield was the conductor.
- Once complete, remove the copper cutting and withdraw the power stripper tool from the cable. Do not remove hand vise from its final position.

 **Warning:** Wear gloves when handling or touching copper cutting to avoid cuts.

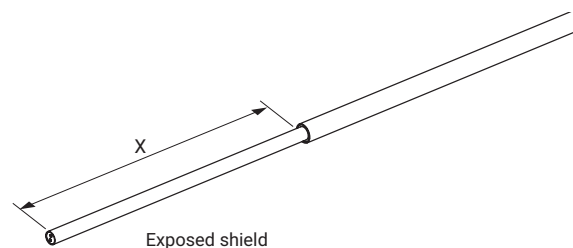
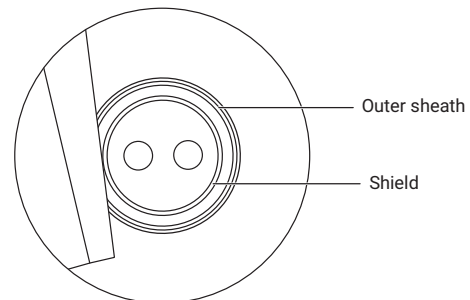

15

**STRIPPING THE INNER SHIELD**

- Remove the head bushing used for the outer sheath and insert the special shield cable bushing (230S or 198S) as required, referring to Table 2.

Table 2: TS Cable Bushings

Bushing group (Part Number)	Cable Reference	Head Bushing Size (Marking)	Guide Bushing Size (Marking)
PWBTs	2/16-364TS	364	281-371
	2/16-364TS Shield	230S*	281-371
	2/18-324TS	324	281-371
	2/18-324TS Shield	198S*	281-371

16

- Move the hand vise 11/32 in (9 mm) closer to the cable end. It should now sit 4-21/32 in (4.66 in or 11.8 cm) from the end of the cable outer sheath. Proceed with stripping the inner copper shield following the standard procedure.
- Position the blade as if the inner shield was the outer sheath, using the conductors as the reference for the blade depth adjustment.

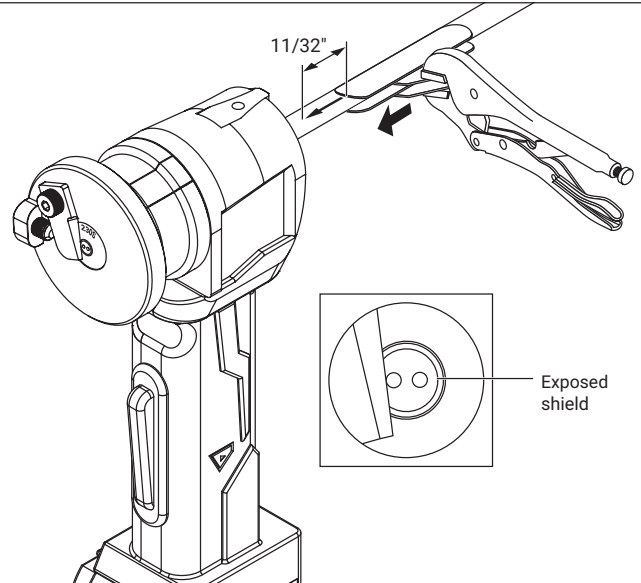

17

- Proceed with stripping the inner copper shield following the standard procedure.
- The shield will be cut clean when the TS cable outer sheath reaches the shoulder inside the bushing or the hand vise, whichever comes first (both should mostly aligned). This ensures just enough shield is exposed to complete the standard TS cable termination.
- Once complete, remove the copper cutting and withdraw the power stripper tool from the cable.

The TS cable is ready for termination. Refer to the termination kit's instruction manual for more details.

**Warning:** Wear gloves when handling or touching copper cutting to avoid cuts.

**Note:** The shield from the TS cables is very soft. Only strip short lengths at a time (2 to 4 in) (5 to 10 cm) maximum to prevent the copper cutting from being tangled. Follow the "STRIPPING CABLES .324 IN DIAMETER AND UNDER" procedure.

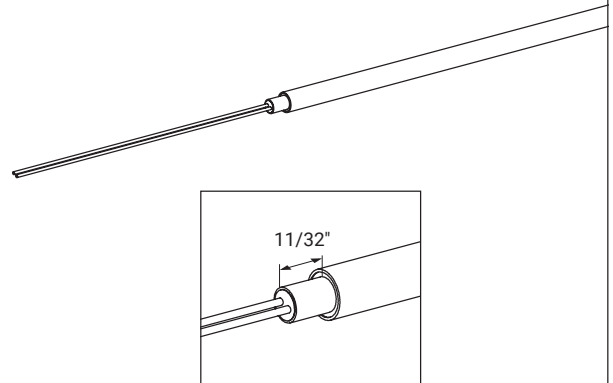

## RE-ASSEMBLING THE BASE TOOL TO RESTORE ORIGINAL TOOL FUNCTIONALITY

18

- Ensure the MI power stripper head and guide bushing have been removed from the tool. If head is on the tool, depress the Bushing Latch to release the stripper head.

 **Warning:** Always remove the battery pack before adding or removing parts.

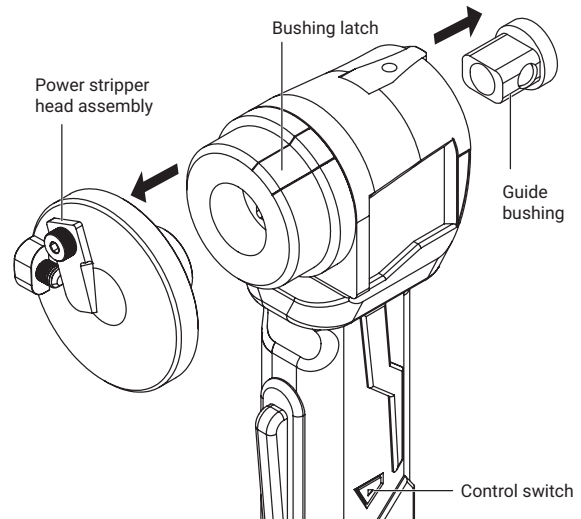

19

- Insert the depth gauge from the front of the power tool, ensuring the depth scale is right side up. Push it all the way until it comes out at the back of the tool.

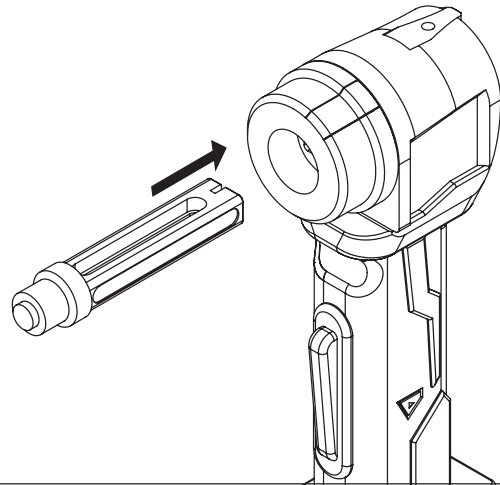

20

- Push the black handle back in from the back of the tool and using the provided 3/32 in Allen Key, secure the bolt at the back of the depth gauge.



21

- Position the square nut under the depth gauge.

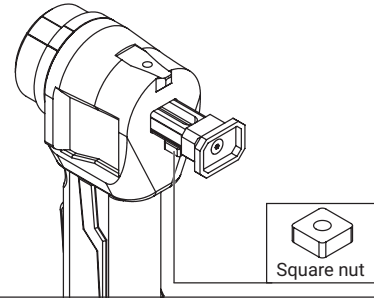

22

- Tighten the screw from the top of the power tool into the square nut.
- The power tool has now been returned to its original functionality.

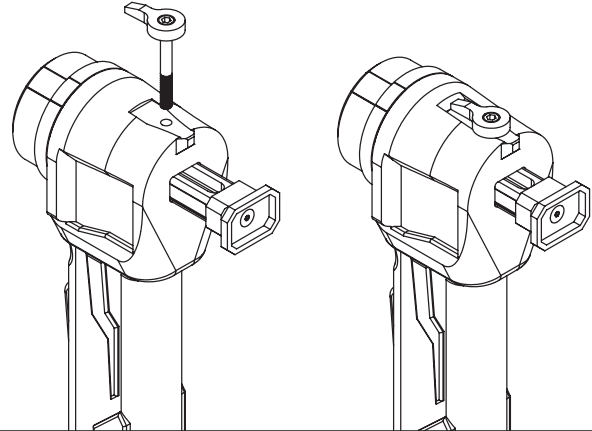

## TROUBLESHOOTING GUIDE

How to back up the power tool in the middle of a cable being stripped:

### Stop the Tool.

Method 1 (when the tool is stopped close to the cable end or close to the area when sheath has been fully removed): Reversing the power tool direction may be enough to bring the tool back to where the problem started. Blade adjustment screw may have to be backed up by half to a full turn.

Method 2 (when too far in or method 1 is not working): Using the Allen Key, loosen the blade locking screw and rotate the blade out of the way by backing up the blade adjustment screw, or, if necessary by removing the blade locking screw. Tool can now be pushed back.

Problem	Corrective Action
1-The blade does not cut fully through the sheath.	<p><b>Cause: The blade is not set deep enough.</b> Action: Stop the tool immediately. Backup the stripper tool until the face of the cable (or the area where the sheath is not fully cut starts) and re-set the blade, pushing it deeper than before but not too deep to cut through the conductors.</p> <p><b>Cause: The blade is worn.</b> Action: Stop the tool immediately. Back up the stripper tool and change blade.</p>
2-The blade scores and damages the conductors	<p><b>Cause: The blade is set too deep.</b> Action: Stop the tool immediately. Back off the blade using the blade adjustment screw until it no longer scores the conductor.</p> <p> <b>Note:</b> If conductor is damaged, cut it off and start stripping from the beginning.</p>

Problem	Corrective Action
3-Power tool slows down and/or stops	<p><b>Cause: Battery is low.</b> Action: Change (or re-charge) battery. Resume stripping (without backing off the tool).</p> <p><b>Cause: Cable is not straight enough.</b> Action: Stop the tool. Pull the stripper tool back out enough that cable can be straightened. Resume stripping after re-adjusting the blade position a needed.</p> <p><b>Cause: Copper cutting is tangled or stopped by conductor.</b> Action: Stop the tool immediately. Cut off short pieces of the "tangled" copper cutting until the conductors are free of it. <b>BE CAREFUL NOT TO CUT CONDUCTORS.</b> Resume stripping short lengths and cutting off the copper cutting regularly before it gets caught. Gently pull on the cutting when possible following the "STRIPPING CABLES .324 IN DIAMETER AND UNDER" procedure.</p>
4-Cable bushing moves out of position and gets caught by blade	<p><b>Cause: Bushing was not fully pushed in at start. Magnesium oxide (MgO) insulation may also gather under the bushing after stripping long lengths of cable.</b> Action: Stop the tool immediately. Using a sharp knife, cut off any nylon shaving that may have formed. If excess MgO is present, back up tool and clean it off. Push tool back in. Ensure the bushing is fully pushed in: face must be flush or lightly recessed inside the stripper head. Resume stripping.</p>
5-Final cut on the cable sheath is not clean or straight; cable end may have a small bend	<p><b>Cause: Incorrect head adapter bushing size was used (if the head bushing is too loose, blade may push and bend the cable ends instead of cutting the sheath cleanly).</b> Action: Refer to Table1 and replace bushing as required.</p> <p><b>Cause: Head adapter bushing is damaged: large dents, bushing face is fully worn or top is missing causing the face to be too far from the blade (if the head bushing face damage is too deep 1/8 in or 3mm, blade may push and bend the cable ends instead of cutting the sheath).</b> Action: Replace the bushing: use Table 1 to find required part number.</p> <p><b>Cause: Blade is worn or damaged.</b> Action: Replace blade.</p> <p> <b>Note:</b> If new bushing is not readily available, a <b>TEMPORARY</b> alternative may be to use the closest bushing size (larger size or next smaller if fitting, per Table 1). Observe the first 1/4 in to 1/2 in (5 to 10 mm) of stripping before proceeding any further. If the problem continues, wait until correct bushing size is available. This method must be used with caution and only as a <b>TEMPORARY</b> solution to finish work already started as it will cause extra wear on the blade, tool, bushing and cable.</p>





**North America**

Tel +1 800 545 6258  
info@chemelex.com

---

**chemelex**  
*excellence is everything*

**Raychem**

**Tracer**

**Pyrotenax**

**Nuheat**