

Raychem

Polymer Insulated (PI)
Series Constant
Wattage Heating
Cable Systems

Installation, maintenance and operation manual

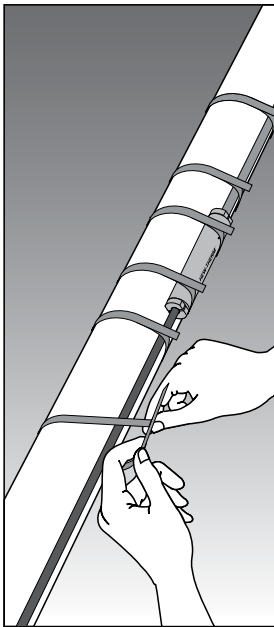

1.	General information	4
2.	Heating cable selection and storage	6
3.	Heating cable installation	8
4.	Components selection and installation	15
5.	Temperature control and limitation	16
6.	Thermal insulation and marking	18
7.	Power supply and electrical protection	19
8.	System testing and commissioning	20
9.	Documentation, operation, maintenance and repairs	21
10.	Trouble shooting	23

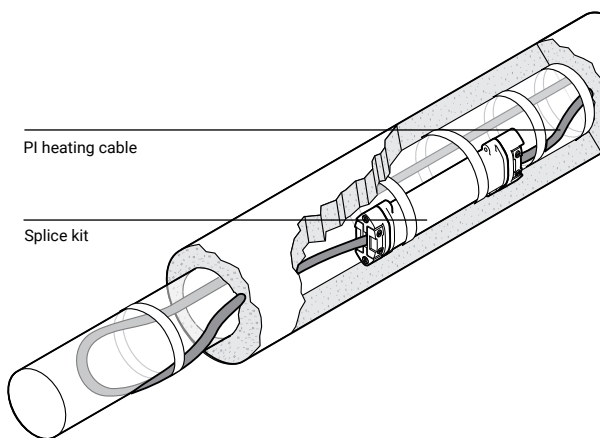

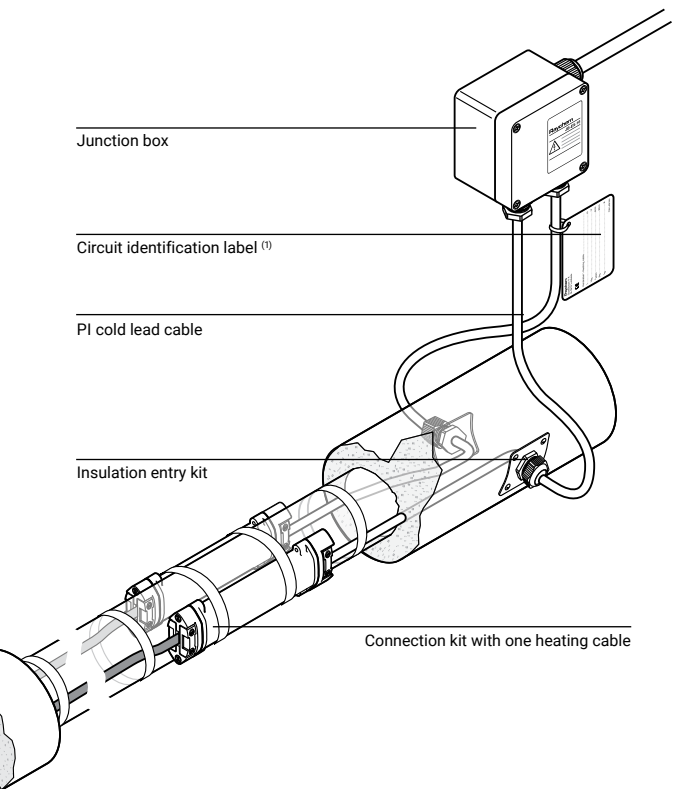

Typical Set Up Of PI-Heating Cable Circuit

(1) The use of the circuit identification label showing all circuit design details is mandatory in hazardous area. (PI-LABEL-EX)

1. GENERAL INFORMATION

Use of the manual

This Installation and Maintenance manual is for Raychem series resistance heating cable systems on thermally insulated pipes, vessels and associated equipment only. In particular it refers to polymer insulated (PI) series heating cable systems, which feature a specific power output, varying with design parameters, mostly with cable length and voltage. This manual provides general information and shows an overview of the most common installations and applications of PI.

In any case, the information provided for specific projects will take precedence over this manual.

Figure 1: Typical Cable Construction

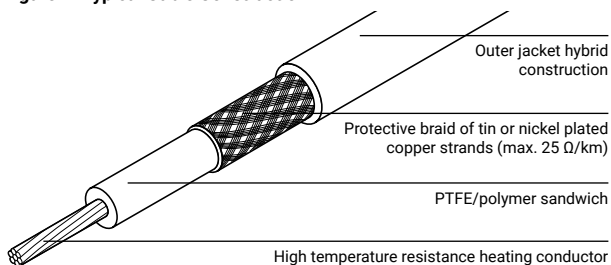

Refer to applicable product datasheet for more detailed information.

Figure 2: Typical heating element set up

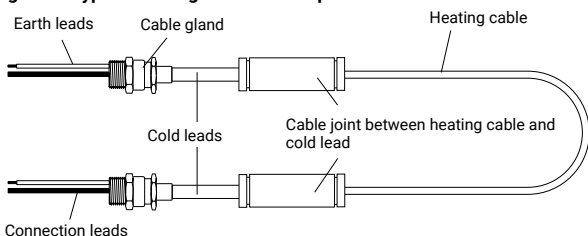

For information regarding other applications contact your Chemelex representative.

Important

For the Chemelex warranty to apply, the instructions that are included in this manual and product packages must be followed. The installation must also be in accordance with local national requirements applicable to electrical heat tracing systems, as well as the requirements of other International Standards.

Personal involved in the installation, testing and maintenance of electric heat tracing systems must be suitably trained in all special techniques required, as well as in general electrical installation work. All work should be monitored by supervisors, experienced in heat tracing applications, and all installations must be carried out using the appropriate tools as described in the Chemelex literature and installation instructions.

Area Classification – Ordinary

XPI-F, XPI and XPI-S

Area Classification - Hazardous, Zone 1 or Zone 2

Schedule of Limitations:

1. The maximum withstand temperature for the XPI- and XPI-S- cable is +260°C. for the XPI-F- cable +90°C and for the CS-150-xx-PI Cold Applied Connection & Splice Kits is +200°C
2. The maximum supply voltage for the XPI cable is shown in the component description
3. The minimum installation temperature is –70°C for the XPI- and XPI-S- cable. –60°C for the XPI-F-cable and for the CS-150-xx-PI Cold Applied Connection & Splice Kits is –50°C
4. The minimum cable spacing must not be less than 20 mm
5. For XPI and XPI-S, the minimum bend radius is 2.5x the cable diameter for cables less than or equal to 6 mm in diameter or the minimum bend radius is 6x the cable diameter for cables greater than 6 mm in diameter. For XPI-F, the minimum bending radius is 7.5 x the cable diameter
6. The XPI- or XPI-F- cable is for use in areas with low risk of mechanical damage, therefore appropriate installation consideration shall be taken. The XPI-S- cable is for use in areas with normal risk of mechanical damage
7. The CS-150-xx-PI Cold Applied Connection & Splice Kits shall be secured when installed. To avoid tensile stress, heating or cold lead cable installation shall be fixed in their position in the immediate vicinity of the connection or splice

CAUTION: XPI cables are only suitable for use in areas with low risk of mechanical damage (e.g. under insulation). In areas with a high level of mechanical impact use XPI-S or conduit system instead!

Certificate No.	Approvals coding
-----------------	------------------

XPI-F, XPI and XPI-S System Approval

PTB 08 ATEX 1102X	⊕ Ex II 2 G Ex eb 60079-30-1 IIC T2... T6 Gb
BAS21UKEX0652X	⊕ Ex II 2 D Ex tb 60079-30-1 IIIC T260... T90°C Db
IECEX PTB 08.0051X	Ex eb 60079-30-1 IIC T2... T6 Gb Ex tb 60079-30-1 IIIC T260... T90°C Db

XPI-F, XPI and XPI-S Bulk Cable Approval

Baseefa15ATEX0158U	⊕ Ex II 2G Ex 60079-30-1 IIC Gb
BAS21UKEX0522U	⊕ Ex II 2D Ex 60079-30-1 IIIC Db
IECEX BAS 15.0105U	Ex 60079-30-1 IIC Gb Ex 60079-30-1 IIIC Db

XPI and XPI-S



EA9C KZ 7100841.01.01.06747
Ex 60079-30-1 IIC T6(80°C)...T2(290°C) Gb X
Ex 60079-30-1 IIIC T80°C...290°C Db X

XPI-F



EA9C KZ 7100841.01.01.06747
Ex 60079-30-1 IIC T4 Gb X
Ex 60079-30-1 IIIC T110°C Db X



Certificate number 2020322312001118
Ex eb IIC Gb

Information on manufacturing

All cables display per meter a print string with the approval and production information, followed by meter marks. In this print string, the last 4 digits prior to the meter marks indicate respectively the week and year of manufacturing.

Example:

Raychem (R) XPI xxx Ohm/km 450/750 V < approval information >
215669875643 **22/2024** - 3587

Week of manufacturing: 22

Year of manufacturing: 2024

2. HEATING CABLE SELECTION AND STORAGE

The selection of the proper heating cable and components, best suited for the application must be checked against the relevant product literature and the product properties, of which the most important are summarized in following table:

Table 1: List of heating cable properties

Heating cable type	XPI-F	XPI	XPI-S
Maximum voltage U0/U (V AC)	300/500	450/750	450/750
Maximum Withstand Temperature (°C)	90	260	260
Short term temperature exposure (°C)	100	300	300
Temperature Classification	T4-T6	T2-T6	T2-T6
Minimum Clearance (mm)(*)	20	20	20
Impact Resistance (J)	4	4	7
Minimum Installation Temperature (°C)	-60	-70	-70
Min. Bending Radius at min installation temp	7.5 x Ø	2,5 x Ø (Ø < 6 mm) / 6 x Ø (Ø ≥ 6 mm)	2,5 x Ø (Ø < 6 mm) / 6 x Ø (Ø ≥ 6 mm)
Max. Power Output (W/m)	See table below or use Raychem Software		
Chemical resistance (*)	Moderate	High	High

(*) - please check against individual datasheet or contact Chemelex for further details.

Table 2: Typical cable limits of power output

Maintain temperature (°C)	Typ. max. cable load (W/m)			
	Good contact		Poor contact	
	XPI/XPI-S	XPI-F	XPI/XPI-S	XPI-F
≤ 10	30	25	25	20
+ 11...30	25	20	20	15
+ 31...50	21	18	18	13
+ 51...75	18	-	15	-
+ 76...100	15	-	12	-
+ 101...125	12	-	10	-
+ 126...150	10	-	8	-
+ 151...200	8	-	5	-

The typical cable power output is shown above in table 2, depending on

application. The maximum cable power output is directly dependent on the application and control method used. The actual limits of PI heating cables in a specific application are given in Engineering Software (e.g. TraceCalc Pro design software). Contact Chemelex for more details.

- Ensure that the heating cable voltage rating is suitable for the service voltage available and that the temperature rating of the heating cable defined by the design is suited for the application

Check equipment to be traced:

- Check identification, dimensions of pipework/vessel, actual temperatures and insulation properties against the design documents
- Ensure all pressure testing of pipework/vessel is complete and final paint and pipe/vessel coatings are dry to touch
- Walk the system and plan the routing of the heating cable on the pipe, including tracing of heatsinks. e.g. valves, flanges, supports, drains etc
- Inspect piping for burrs, rough surfaces, sharp edges etc. which could damage the heating cable. Smooth off or cover with layers of glass cloth tape, aluminium foil or rubber profiles (e.g. G-02)
- Ensure that the heating cable voltage rating is suitable for the service voltage available and that the temperature rating of the heating cable defined by the design is suited for the application

Changing any major design parameters like voltage or cable length will result in power output other than designed, which may require a redesign of the entire system. To prevent overload of the heating cable, fire or explosion in hazardous areas, verify that the maximum sheath temperature of the heating cable is below T-class or auto-ignition temperature of the gases and/or dusts possibly present in those areas. For further information, see design documentation (e.g. TraceCalc Pro reports).

Check the design specification to ensure the proper heating cable is installed on each pipe or vessel. Refer to Raychem product literature to select an appropriate heating cable for each thermal, chemical, electrical and mechanical environment.

Storage and transportation

- Store and transport product in a clean, dry place
- Temperature range: -70°C for XPI and XPI-S, -60°C for XPI-F to $+56^{\circ}\text{C}$ for all
- Protect the heating cable from moisture or mechanical damage
- Keep ends of heating cables and kit components dry before and during installation

3. HEATING CABLE INSTALLATION

WARNING: As with any electrical equipment or wiring installation that operates at line voltages, damage to heating cable and components, or incorrect installation that allows the penetration of moisture or contamination can lead to electrical tracking, arcing and potential fire hazard.

Any unconnected heating cable end, exposed to the environment, must be sealed appropriately.

3.1 Pre-installation checks

Check design recommendations:

- Verify that you have all required engineering documents supporting the installation
- Check for any special instructions in engineering documentation (e.g. fixation method, use of metal mesh etc...)
- Verify that the hazardous area information given in the engineering documentation is compatible with the area classification the material will be installed in

Check materials received:

- Inspect heating cable and components for in-transit damage
- Review the heating cable design and compare the list of designed materials to the catalog numbers of heating cables and electrical components received to confirm that proper materials have been received on site. The heating cable type and hazardous area marking is printed on the outer jacket. The application related hazardous area details and relevant design data for each individual heating circuit are recorded on a hazardous area label. (see 7.3)
- Measure and note down the electrical resistance and the insulation resistance of the cable. Compare these values to those in the design documents (see section 8)

Check equipment to be traced:

- Check identification, dimensions of pipework/vessel, actual temperatures and insulation properties against the design documents
- Ensure all pressure testing of pipework/vessel is complete and final paint and pipe/vessel coatings are dry to touch
- Walk the system and plan the routing of the heating cable on the pipe, including tracing of heatsinks. e.g. valves, flanges, supports, drains etc
- Inspect piping for burrs, rough surfaces, sharp edges etc. which could damage the heating cable. Smooth off or cover with layers of glass cloth tape, aluminium foil or rubber profiles (e.g. G-02)

3.2 Heating cable pulling and laying

Heating cable pulling tips:

- Use a reel holder that pays out smoothly with little tension

Figure 3: Importance of cable pulling direction

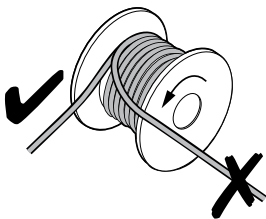

- Avoid distortion of the cable and kinking
- When pulling the heating cable, **avoid**:
 - sharp edges
 - excessive pulling force
 - kinking and crushing
 - walking on it, or running over it with equipment
- Keep heating cable strung loosely but close to the pipe being traced, to avoid interference with supports and other equipment
- Add additional heating cable to trace the fittings, supports and other accessories as required by the design specification
- Leave the appropriate amount of heating cable at all power connection, splice and tee locations. (Refer to component installation instructions)
- Pay out designed length and mark (i.e. with fixing tape) on cable while remainder of cable still on reel (XPI: use printed metermarks for orientation)

3.3 Heating cable attachment

- **Do not use metal bandings, tie wire, vinyl electrical tape or duct tape, as heating cable damage may result. Only use attachments as specified in the design documentation**

Fix in place with a minimum of two wraps of the appropriate self-adhesive glass cloth tape, metal mesh or fixing strip at 300 mm intervals and additionally where necessary. Other attachments (like aluminium tape) may be specified in the design documentation

- Cable must be installed and fixed as such, that movement of cable during its heating up cycles is permitted, but not to allow the cable to move freely under its own weight. The heating cables may be installed in straight, multiple runs as required by the design specification
- On horizontal pipes fix on lower quadrant as shown below and not on bottom of pipe

Figure 4: Cable orientation on pipe

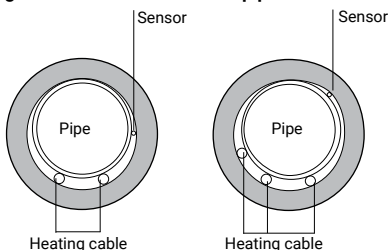

Read the design documents, in particular concerning the need for cable allowances and regard the location of junction boxes/controllers before permanently attaching the cable to the pipe.

- When installed in vertical runs, do not let heating cable hang and carry its own weight but ensure sufficient support with steel strips. (e.g. every 2 m)
- Installation on tanks might require additional fixation devices as prepunched steel strips as shown on the next page:

Figure 5: Typical cable layout on bigger surfaces as tank walls

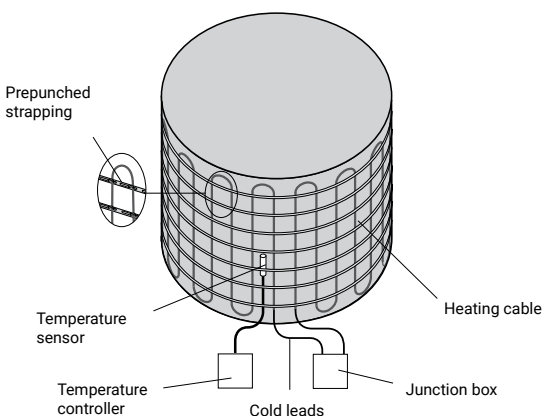
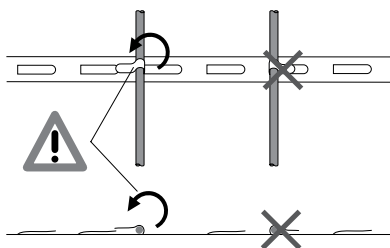

Figure 6: Fixation device: prepunched steel strap



Use insulation entry kits, where cable penetrates the metallic insulation cladding by design. In all other places, where cable passes through metal sheet like cladding front disks (e.g. on valves) protective rubber profiles G-02 should be used to mechanically protect the cable.

3.4 Cutting the heating cable

- Before cutting it, confirm the minimum required length and tracing allowances
- **Any change to designed circuit length will change power output and design must be reconfirmed**
- Cut the heating cable to length after it is attached to the pipe

3.5 Attachment tapes, mesh and strips

- GT-66 Glass cloth tape for attaching heating cable to pipe. Not for stainless-steel pipes or for installation temperatures below 5°C
- GS-54 Glass cloth tape for attaching heating cable to pipe. For stainless-steel pipes or for any installation below 5°C
- ATE-180 Aluminium tape for attaching the cable to vessels. For all surfaces and installations above 0°C
- HWA-METAL-MESH-SS-50MM-10M : Stainless-steel for attaching heating cable onto valves, pumps or other odd shaped surface.
HWA-PI-FIX-SS-xMM-10M : Stainless-steel clip band for attaching heating cables to pipes ensuring a regular spacing (e.g. triphase systems)
- At long straight lengths, expansion loops may be needed to allow for thermal expansion of the pipe without exposing cable to excess of strain. Other attachment methods could be specified. In that case, please refer to the design documentation

3.6 Typical installation details

Typical installation details for fixing heating cable to pipe fittings are shown hereafter.

Figure 7: Typical cable allowance on pipe shoe

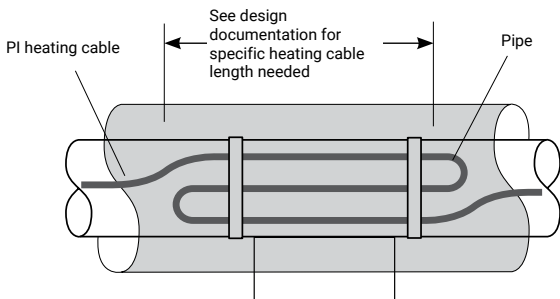

! PI heating cables must not be overlapped and the minimum clearance must be respected. Refer to the design documentation for more info or contact Chemelex for assistance.

Figure 8: Typical cable allowance on valve

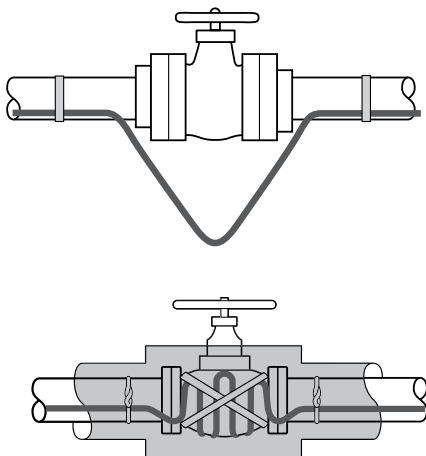

! PI heating cables must not be overlapped and the minimum clearance must be respected. Refer to the design documentation for more info or contact Chemelex for assistance.

Figure 9: Typical cable routing on pipe elbows

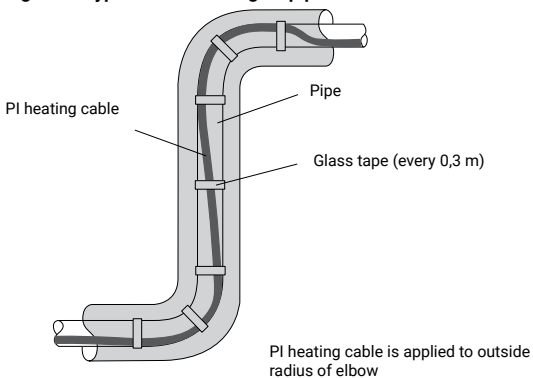
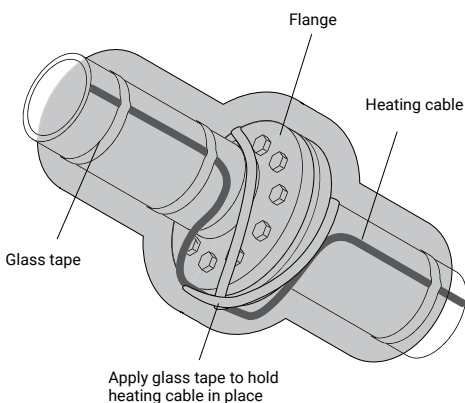

Figure 10: Typical cable routing on flanges



⚠ PI heating cables must not be overlapped and the minimum clearance must be respected. Refer to the design documentation for more info or contact Chemelex for assistance.

General note:

- Trace pipe fittings as shown to allow easy maintenance. Alternatively wire mesh cages might be used

Figure 11-12: Cable applied on wire mesh

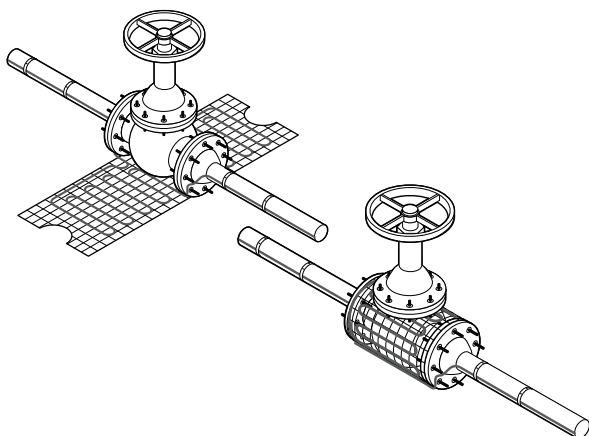

⚠ Do not use tie wire or straps to attach the heating cable to the wire mesh. Use tape.
After installing the cable onto the mesh, push the mesh firmly against the valve body to optimize contact between cable and valve body. Air gaps between cable and heated surface should be minimized as much as possible.

- Consult the design specification for the heat tracing requirements for fittings and supports
- Follow the instructions for cutting and stripping of heating cables; they are included in the individual component installation instructions
- The heating cable's minimum bend radius must be respected (refer to Table 1), together with the minimum clearance. Refer to the design documentation for more info or contact Chemelex for assistance
- Refer to the design documentation to ensure the correct attachment method is used

Figure 13: Minimal bending radius of cables

Bending the cable for XPI and XPI-S:

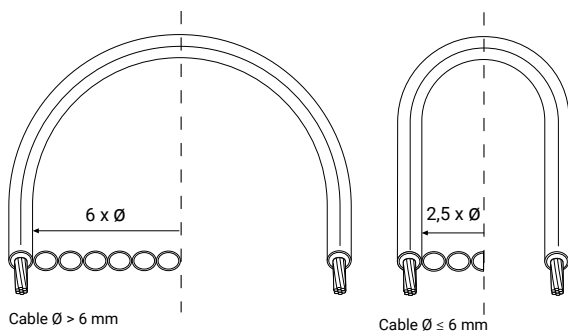

For XPI-F : 7.5 x Ø for all cables

- When installing constant wattage heating cables, ensure that they do not overlap or cross. Doing so may lead to local overheating and hazard of fire

Figure 14: Minimum clearance between heating cables must be respected

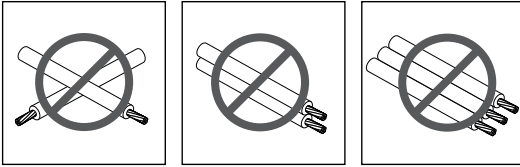

Minimum clearance: 20 mm. For hazardous area applications, please consult the Raychem design software, e.g. TraceCalc Pro.

3.7 Heating cable allowances

All parts of a heat traced system that increase the surface area of the normally insulated pipe/ vessel or metallic fins that protrude out of the insulation (e.g. supports), will increase the overall heatloss.

These areas of increased heat loss require compensation, either by using higher overall design safety factors or by the addition of extra cable length.

In such cases sufficient cable should be added in such a way to at least enable removal of instruments, valves etc (“maintenance loop”).

For pipes requiring more than one run of heating cable, apply the full allowance for each run of cable on each fitting or support as long as space allows. However, PI heating cables must not touch or overlap and the minimum spacing between the heating cables must be respected.

For some applications, it may be physically impossible to install all of the recommended allowance directly on the fitting or support. In this case, install the excess heating cable on the pipe on either side of the fitting or support, or distribute the additional heater length along the entire circuit length if a lower local temperature is acceptable. If required, contact Chemelex for assistance.

For further details on individual allowances please refer to the design documentation or the Raychem design software (e.g. TraceCalc Pro reports).

4. COMPONENTS SELECTION AND INSTALLATION

General notes:

Use the Design Specification to select required components.

Raychem component kits must be used to satisfy Standards and Approval Body requirements and the Chemelex warranty to apply. Installation instructions included in the kit must be followed, including those for preparation of the heating cable connections. Before assembly, use the guide given in the instructions, to ensure that the kit is correct for the heating cable and environment. The Components certified for use in conjunction with XPI-F, XPI and XPI-S heating cables are: Raychem CS-150-2,5-PI, CS-150-6-PI, CS-150-25-PI and CS-150-UNI-PI.

4.1 Components required

- For installation of all components refer to the relevant component installation instructions
- Required for each heating cable end: Cold lead connection and insulation entry kit
- As required: Splice kits and accessories (fixing tape, support brackets, pipe straps, labels, etc)

4.2 Component installation hints

- On horizontal pipes locate junction boxes below pipe wherever possible
- Locate junction boxes for easy access, but not exposed to mechanical abuse
- Try to position junction boxes such, that power cable and heating cable entries point downwards, to minimize water ingress in the insulation
- Confirm junction box glands and stopping plugs are correct for application and fixed firmly in place
- Route heating cable between junction box and place where it enters the insulation cladding such, that the risk of mechanical damage is minimized
 - **Do not strain heating cable as it exits/enters junction boxes and insulation entries**
- Ensure heating cable is fixed over pipe straps such as used for junction box support brackets to avoid potential mechanical damage

Figure 15: Cable layout over clamps and straps

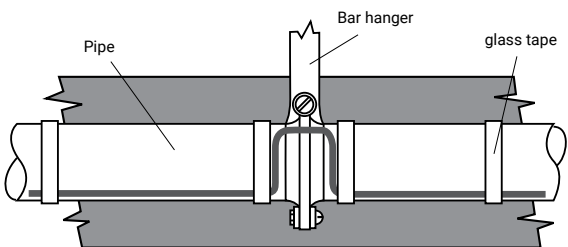

- Cable joints (splices) should be placed only in places, where cable is not bent or mechanically stressed

5. TEMPERATURE CONTROL AND LIMITATION

5.1 General rules

Raychem PI series heating cables are constant power output heaters and as such typically require temperature control, unless otherwise explicitly specified.

Good practice and local regulations may require additionally independent temperature limitation devices. The selection of such devices also depends on environmental conditions (non-haz. or haz. area)

- For applications in hazardous areas either a stabilised design or a thermostat control with temperature limiter complying with the requirements EN 60079-30 can be used to limit the surface temperature of the heating cable
- In cases where stabilised design is **not** applied, a control thermostat ensures that under normal conditions, the heating system will be switched off, as soon as maintain temperature is reached

An additional, independent temperature limiter ensures that if the control thermostat fails, the surface temperature of the heating cable will not exceed the maximum allowed temperature for hazardous area by switching off the heating cable.

General features of such a limiting device:

- A lockout function ensures that the heating cable remains switched off, until failure has been eliminated and normal conditions are restored. The lockout function is manually re-armed. Reset requires a tool (e.g. a key to open a panel or a password for software).
- Value of setpoint has to be secured against unintended change
- Limiter must permanently switch off in case of sensor malfunction
- The limiter function complies to all relevant standards (e.g. EN60730 or DIN3440 etc.)
- Follow the installation instructions supplied with the thermostat and/or the limiter
- Use a proper wiring diagram for the heating cable layout and control method desired
- The limiter must be set to ensure that the maximum temperature of the surface of the cable does not exceed neither T-class nor maximum working temperature of the heater for a given output under worse case conditions

⚠ WARNING: As with any temperature measurement equipment, possible falsification of true temperatures due to increased heatloss caused by the sensor itself might lead to inaccurate temperature readings or unsafe tripping of safety limiters. The setpoint might need to be adjusted accordingly Contact Chemelex or the supplier of the limitation device in order to obtain detailed information concerning offsetting of limitation devices.

5.2 Sensor placement: Temperature control device

The choice of the right location for the controller sensor depends on, but is not limited to following aspects:

- Flow direction of the fluid, best location: downstream
 - Impact of heatsinks such as supports etc, best: close to heatsink
 - Chimney effect on large size vertical pipes, best: on the bottom
 - Accessibility for maintenance purposes, best: at ground level
 - Impact of other heat sources, sun etc, best: at cold side
- For details please refer to the engineering documentation

5.3 Sensor placement: limitation device

Typically the sensor is being placed on a length of cable, that is separated from the pipe by means of insulating material, in order to create an "artificial hotspot".

The choice of the right location for the limiter sensor depends on, but is not limited to following aspects:

- Flow direction of the fluid, best location: upstream
- Impact of heatsinks such as supports etc, best: away from heatsinks.
- Accessibility for maintenance purposes, best: at ground level
- Chimney effect on large size vertical pipes, best: at the top
- Impact of other heat sources, sun etc, best: at hot side of pipe
- It is the responsibility of the installer to ensure that these conditions are met in the most appropriate way
- For details please refer to the engineering documentation

6. THERMAL INSULATION AND MARKING

6.1 Pre-insulation checks

- Visually inspect the heating cable and components for correct installation and possible damage. (See Section 10 if damaged.)
- Insulation resistance testing (as per Section 8) is strongly recommended prior to covering the pipe with thermal insulation

6.2 Insulation related requirements

- Correct temperature maintenance requires properly installed and dry thermal insulation
- Check that all pipework, including fittings, wall penetrations and other areas are completely insulated
- Thermally insulate and weatherproof to design specification
- Polymeric heating cables need to be protected against mechanical damage. Metallic insulation cladding is considered as sufficient mechanical protection
- Ensure that heating cable is not damaged during installation of cladding by drills, self tapping screws and sharp edges of cladding etc
 - **In all stabilised design cases, the characteristics of the installed thermal insulation (material and thickness) must comply with the design requirements and be verified and confirmed in the documentation, to ensure compliance with approvals requirements**
 - **Make sure, that under no circumstances any insulation material is being placed between heated surface and cable, thus disabling intended heat flow to the substrate, which may result in possible overheating of the cable**
- Good practise requires wrapping of the installed heating system with an appropriate metal foil prior to installation of the thermal insulation. This is especially so at places where intimate contact between trace heating cable and heated surface is not possible, such as valves or flanges where a suitable heat sink of temperature rated metal foil may be used. Details may be described in local insulation standards
- Check that all insulation entry kits are fitted correctly or that other alternative protective devices (such as rubber profiles G-02) are used, where appropriate
- Ensure that all places are sealed where thermostat capillaries, sensor cables or support brackets etc. exit the cladding

6.3 Marking

- Install "Electric Traced" signs on the insulation cladding along piping at suitable intervals (3-5 m intervals recommended) on alternate sides as a warning
- Mark on outside of insulation the location of any heating cable components like connection points, splices etc

7. POWER SUPPLY AND ELECTRICAL PROTECTION

- **Do not energize cable when it is coiled or on the reel**
- **The Metal sheath /braid of this heating cable must be connected to a suitable earthing terminal**

7.1 General

For installations in hazardous area, each circuit shall have the means of isolating all line conductors from the supply.

7.2 Electrical loading

Size overcurrent protective devices according to the design specification and/or local standard practises.

7.3 Residual current (earth fault) protection

Properly rated ground fault protection equipment is required for each circuit. Chemelex requires the use of a 30 mA residual current device to provide maximum safety and protection from fire.

Where design results in higher leakage current, the preferred trip level for adjustable devices is 30 mA above any inherent capacitive leakage characteristic of the heating element as specified by the heating cable supplier or alternatively, the next common available trip level for non adjustable devices, with a maximum of 100 mA or 300 mA (Depending on area classification).

All safety aspects need to be proven.

For any heating cables installed in a hazardous area, the use of residual current devices is mandatory by the electrical codes and standards.

7.4 Circuit marking

For all hazardous area installations make sure, that system is properly marked with a Haz area label such as PI-LABEL-EX, which needs to be completed with design data by the responsible installer. Results of design documentation (TraceCalc Pro) may be used.

8. SYSTEM TESTING AND COMMISSIONING

⚠ WARNING: Fire hazard in hazardous locations.

Megger tests can produce sparks. Be sure there are no flammable vapors in the area before performing this test (hot work permit).

⚠ CAUTION: De-energise all power circuits before installing or servicing.

8.1 Testing of insulation resistance and conductor resistance

Chemelex recommends insulation resistance test

- before installing heating cable
- before installing thermal insulation
- prior to initial start-up/ after completion of thermal insulation
- as part of the periodic maintenance. (see Section 9.2). The heating circuit electrical resistance needs to be measured and compared to the design documentation before initial startup

8.2 Test method for insulation resistance testing

After completing heating cable installation, the insulation resistance between the conductor and the braid has to be tested (see Section 6.1).

The minimal required test voltage is 500 Vdc, but the trace heating standard EN60079-30 strongly recommends to use a testing voltage of 2500 Vdc. Hence Chemelex field acceptance test should be carried out with a test voltage of 2500 Vdc and the minimum reading shall be 20 MΩ, regardless of the heating cable length.

The installer should record the values for each circuit on the installation record sheet.

Tip: Discharge heating cable before disconnecting from the Megger

8.3 Commissioning

- Verify all system documentation is complete as per "9.1 Documentation"
- Record and retain all installation & post insulation test values as per the Installation record sheet in this document

9. DOCUMENTATION, OPERATION, MAINTENANCE AND REPAIRS

⚠ WARNING: Heating cables are capable of reaching high temperatures during operation and can cause burns when touched. Avoid contact when cables are powered. Insulate the pipe before energizing the cable. All work needs to be carried out by properly trained personnel.

⚠ CAUTION: The presence of heating cables shall be made evident by the posting of caution signs or markings at appropriate locations and/or at frequent intervals along the circuit.

9.1 Documentation

The trace heating system documentation shall be retained for each trace heating circuit for as long as the system is in use. As a minimum, the trace heating system documentation shall include the following information:

- trace heating circuit identification
- heating cable type;
- operating voltage;
- trace ratio;
- length or dimensions of heating cable;
(this data is also indicated on the tag attached to the heat tracing circuit)

In case of stabilized design:

- temperature to be maintained or the maximum process / exposure temperature;
- maximum ambient temperature;
- maximum workpiece temperature;
- temperature class or maximum sheath/surface temperature as applicable;
(this design & temperature data are also indicated on the tag attached to the heat tracing circuit)
- pipe size or workpiece dimensions;
- thermal insulation type, size, and thickness;
- thermal insulation cladding specification, if applicable
(this data is usually part of the as-built documentation or the detailed calculation reports from design software such as TraceCalc Pro, TracerLynx,...)

In case of controlled design:

- location of the sensor of the temperature controller / limiter on the pipe / workpiece;
- details of the mounting of the sensor
- temperature to be maintained or the maximum process / exposure temperature;
- maximum ambient temperature;
- temperature controller / limiter set point;
- temperature class or maximum sheath/surface temperature as applicable.
(this design & temperature data are also indicated on the tag attached to the heat tracing circuit)

- location of the sensor of the temperature controller / limiter on the pipe / workpiece;
 - details of the mounting of the sensor
 - details for any failure annunciation and monitoring (alarm or lim lock out)
- (this data is usually part of the as-built documentation)

9.2 Heating cable operation

- **Temperature exposure of the cable must be within the range specified in the product literature. Exceeding the limitations will shorten the service life and may permanently damage the heating cable**
- Pipe insulation must be complete and dry to maintain the required temperature

9.3 Inspection and maintenance

- Visual inspection: exposed heating cable should be checked periodically to make sure that no mechanical damage has occurred.
 - Insulation resistance testing: The system should be tested regularly. Check in advance, whether hazardous area conditions allow insulation resistance testing. A hot work permit might be required
 - When measuring the insulation resistance from the main supply panel, the test is performed between L and PE. Optional testing could be performed between braid and pipe (disconnect heating cable ends)
 - Functionality test of electrical protection: Circuit breaker and residual current device should be tested at least once a year or according to manufacturer's instructions
 - Functionality test of temperature control systems: Depending on how essential temperature control is regarding process requirements and how critical temperature limitation is for fulfillment of hazardous area requirements, tests should be carried out at regular intervals
 - The Installation Record Sheet on the following pages should be completed during maintenance of each circuit in your system
- Freeze protection systems should be tested before the winter months each year (see section 8). Temperature maintenance systems should be tested at least twice a year.

9.4 Piping systems repair and maintenance

- Isolate heating cable circuit and protect the heating cable from mechanical or thermal damage during pipe repair work
- Check heating cable installation after pipe repairs and make sure that thermal insulation is restored according to the recommendations in Section 6. Check correct functioning of all relevant electrical protection systems

10. TROUBLE SHOOTING

⚠ WARNING: Damage to cables or components can cause sustained electrical arcing or fire. Do not energize heating cables that have been damaged. Damaged heating cable, splices or connections must be repaired or replaced. Damaged cable should be repaired by a qualified person.

- It should be carefully evaluated, whether the severity of the damage allows on-site repair or whether the entire heating cable needs to be replaced

Also refer to the Troubleshooting guide on the following pages. If the problem persists after following the guidelines, contact Chemelex.

⚠ CAUTION: consult the trace heating system documentation prior to maintenance/repair/modification

After maintenance/repair/modification, test the operation of the earth-fault device of each affected circuit.

In the event of an earth fault or over current interruption, the device shall not be reset until the cause of the trip has been investigated by qualified personnel.

Upon completion of maintenance/repair/modification, the insulation resistance of the heating cable shall be measured and recorded after installation and shall not be less than 20 Mohm.

Monophased installation record sheet

Date:

Installation company:	<input type="text"/>	Installer:	<input type="text"/>
Project / Site name:	<input type="text"/>		
Area name:	<input type="text"/>		
Average pipe temperature when measuring loop resistance:	<input type="text"/>	°C	<input type="text"/>
Heating circuit no.:	<input type="text"/>		
P & ID -no.:	<input type="text"/>		
Drawing no.:	<input type="text"/>		
Panel/Circuit breaker no.:	<input type="text"/>		
Cable type:	<input type="text"/>		
Total Cable length (m):	<input type="text"/>	m	<input type="text"/>

	Required value	Actual value	Signature
1 Visual inspection			
1a Minimal allowed spacing	mm*	mm	
1b Minimal bending radius	mm*	mm	
1c Temperature sensor properly installed on the pipe/vessel & control temperature is set			yes:
1d Sensor of temperature limiter properly installed and set according to design specification			yes:
2 Before commencing of thermal insulation works			
2a Insulation resistance test voltage (V dc)	≥ 2500 Vdc	Vdc	
2b Insulation resistance of cable	> 20 MΩ	MΩ	
2c Cable resistance:	Ω	Ω	yes:
2d Cable covered with aluminium foil at flanges & cable on valves with wire mesh cages			yes:
3 After finalization of thermal insulation works			
3a Cables entries are sealed and cable protected at entries into insulation cladding			yes:
3b Thermal insulation material meets design requirements	*		yes:
3c Thermal insulation thickness meets design requirements	mm*		yes:

	Required value	Actual value	Signature
3d	Warning labels installed on cladding	every 5 m/ at components	yes:
3e	Insulation resistance test voltage (Vdc)	≥ 2500 Vdc	Vdc
3f	Insulation resistance of cable	> 20 MΩ	MΩ
4 Prior to energizing of the cable			
4a	Circuit feeding box marked properly		yes:
4b	Control temperature set to setpoint	°C*	°C*
4c	Limiter set to trip value and protected against damages	°C*	°C*
4d	Insulation resistance test voltage (Vdc)	≥ 2500 Vdc	Vdc
4e	Insulation resistance at commissioning of cable	> 20 MΩ Ω	MΩ
4f	Circuit voltage at feeding box	Vac L-N*	Vac L-N
	Remarks:	Vac L-L*	Vac L-L
	(fill in what is applicable)		
(*) Value to be taken from design documentation.			
General note: Local / national rules and standards need to be respected where applicable.			

Triphased installation record sheet

Date:

Installation company:	<input type="text"/>	Installer:	<input type="text"/>
Project / Site name:	<input type="text"/>		
Area name:	<input type="text"/>		
Average pipe temperature when measuring loop resistance:	<input type="text"/>	°C	<input type="text"/>
Heating circuit no.:	<input type="text"/>		
P & ID -no.:	<input type="text"/>		
Drawing no.:	<input type="text"/>		
Panel/Circuit breaker no.:	<input type="text"/>		
Cable type:	<input type="text"/>		
Cable length first segment:	<input type="text"/>	m	<input type="text"/>
Cable length second segment:	<input type="text"/>	m	<input type="text"/>
Cable length third segment:	<input type="text"/>	m	<input type="text"/>
Configured in:	<input type="text"/>		DELTA / STAR (cross out what is not applicable)

	Required value	Actual value	Signature
1 Visual inspection			
1a Minimal allowed spacing	mm*	mm	
1b Minimal bending radius	mm*	mm	
Temperature sensor properly installed on the pipe/vessel & control temperature is set			yes:
Sensor of temperature limiter properly installed and set according to design specification			yes:
2 Before commencing of thermal insulation works			
2a Insulation resistance test voltage (V dc)	≥ 2500 Vdc	Vdc	
2b Insulation resistance segment 1	> 20 M Ω	M Ω	
Insulation resistance segment 1	> 20 M Ω	M Ω	yes:
Insulation resistance segment 1	> 20 M Ω	M Ω	
2c Segment 1 resistance:	Ω^*	Ω^*	
Segment 2 resistance:	Ω^*	Ω^*	
Segment 3 resistance:	Ω^*	Ω^*	
2d Cable covered with aluminium foil at flanges & cable on valves with wire mesh cages			yes:
3 After finalization of thermal insulation works			
3a Cables entries are sealed and cable protected at entries into insulation cladding			yes:
3b Thermal insulation material meets design requirements	*		yes:
3c Thermal insulation thickness meets design requirements	mm*		yes:

	Required value	Actual value	Signature
3d	Warning labels installed on cladding	every 5 m/ at components	yes:
3e	Insulation resistance test voltage (Vdc)	≥ 2500 Vdc	Vdc
3f	Insulation resistance segment 1	> 20 MΩ	MΩ
	Insulation resistance segment 1	> 20 MΩ	MΩ
	Insulation resistance segment 1	> 20 MΩ	MΩ
4	Prior to energizing of the cable		yes:
4a	Circuit feeding box marked properly		yes:
4b	Control temperature set to setpoint	°C*	°C*
4c	Limiter set to trip value and protected against damages	°C*	°C*
4d	Insulation resistance test voltage (Vdc)	≥ 2500 Vdc	Vdc
4e	Insulation resistance at commissioning segment 1	> 20 MΩ Ω	MΩ
	Insulation resistance at commissioning segment 1	> 20 MΩ Ω	MΩ
	Insulation resistance at commissioning segment 1	> 20 MΩ Ω	MΩ
4f	Circuit voltage at feeding box	3 x Vac L-N*	3 x Vac L-N
		3 x Vac L-N*	3 x Vac L-N
		Vac L-L*	Vac L-L
Remarks:	(fill in what is applicable)		
(*) Value to be taken from design documentation.			
General note: Local / national rules and standards need to be respected where applicable.			

Trouble shooting guide

A **Symptom:** Overcurrent protection trips.

Probable Causes

- 1 Electrical fault at:
 - a damaged heating cable
 - b faulty splices
 - c cold lead connections
 - 2 Circuit oversized
 - 3 Defective electrical protection
 - 4 Start-up below minimum design temperature (copper conductor only)
-

B **Symptom:** RCD trips.

Probable Causes

- 1 Earth fault at:
 - a damaged heating cable
 - b faulty splices
 - c cold lead connections
 - 2 Excessive moisture in:
 - a junction boxes
 - b splices and cold lead connections
 - 3 High leakage currents due to a combination of excessive lengths of power cable and heating cable.
 - 4 Defective RCD
 - 5 Mains borne disturbances
-

Corrective actions

- 1 Investigate and remedy

 - 2 Resize or redesign

 - 3 Replace

 - 4
 - a redesign for lower startup temperatures.
 - b preheat pipe from alternative heat source to temperatures considered in electrical design
 - c employ soft start techniques of control system to smoothly heat up system.
-

Corrective actions

- 1 Investigate and remedy

 - 2 Dry out and reseal or remake immediately and perform insulation resistance test.

 - 3 Redesign

 - 4 Replace

 - 5 Redesign distribution
-

C **Symptom:** No power output.

Probable Causes

-
- 1 Temperature limiter is tripped
-
- 2 Loss of supply voltage due to:
- a overcurrent protection or residual current protection operating
 - b loose terminals in junction box, bad splice
 - c loss of supply cable continuity (open circuited from damage)
-
- 3 Temperature controller defect
-

D **Symptom:** Low pipe temperature.

Probable Causes

-
- 1 Wet thermal insulation
-
- 2 Incorrect setting or operation of temperature controls e.g., thermostats.
-
- 3 Design error
-

Note:

Locate faults by the following steps:

- 1 Visually inspect the power connections and splices for correct installation.
- 2 Look for signs of damage at:
 - a) Valves, pumps, flanges and supports.
 - b) Areas where repairs or maintenance work has been carried out recently.
- 3 Look for crushed or damaged insulation and cladding along the pipe.

Corrective actions

- 1 Investigate causes, restore normal conditions and re-arm
 - 2 Restore supply voltage
 - a following A and B
 - b re-tighten terminals, replace splice connection
NB: If excessive heating has occurred due to high resistance, replace terminals or crimps
 - c locate damage and repair
 - 3 Investigate causes, replace equipment
-

Corrective actions

- 1 Remove and replace with dry insulation of correct specification and ensure complete weatherproofing
 - 2 Repair or reset to correct level of operation
 - 3 Check with competent authority for design conditions and modify to meet Chemelex recommendations
-
- 4 If after 1, 2 and 3 above the fault has not been located, then either:
 - a) Consult Chemelex for further assistance.
 - b) Where local practices and conditions allow (e.g., non-hazardous areas) isolate one section of heating cable from another by cutting in half and testing (e.g., insulation resistance) both halves until general area of damage is found.
Remove insulation and expose fault.

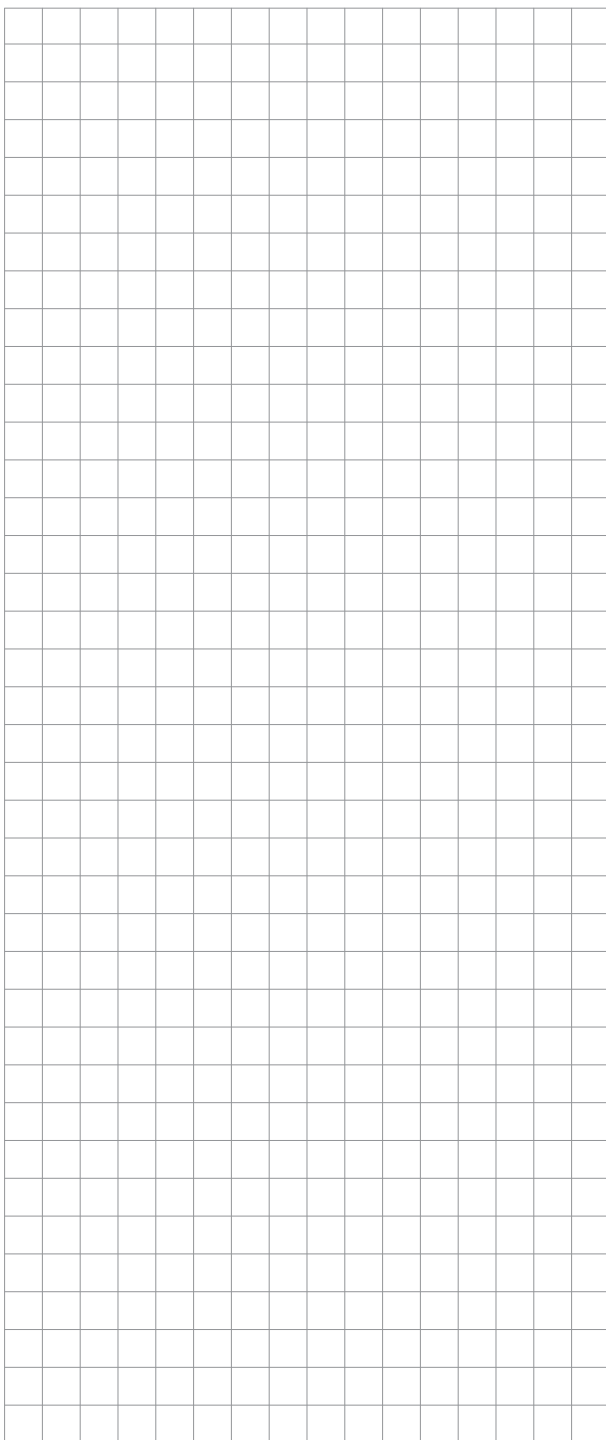

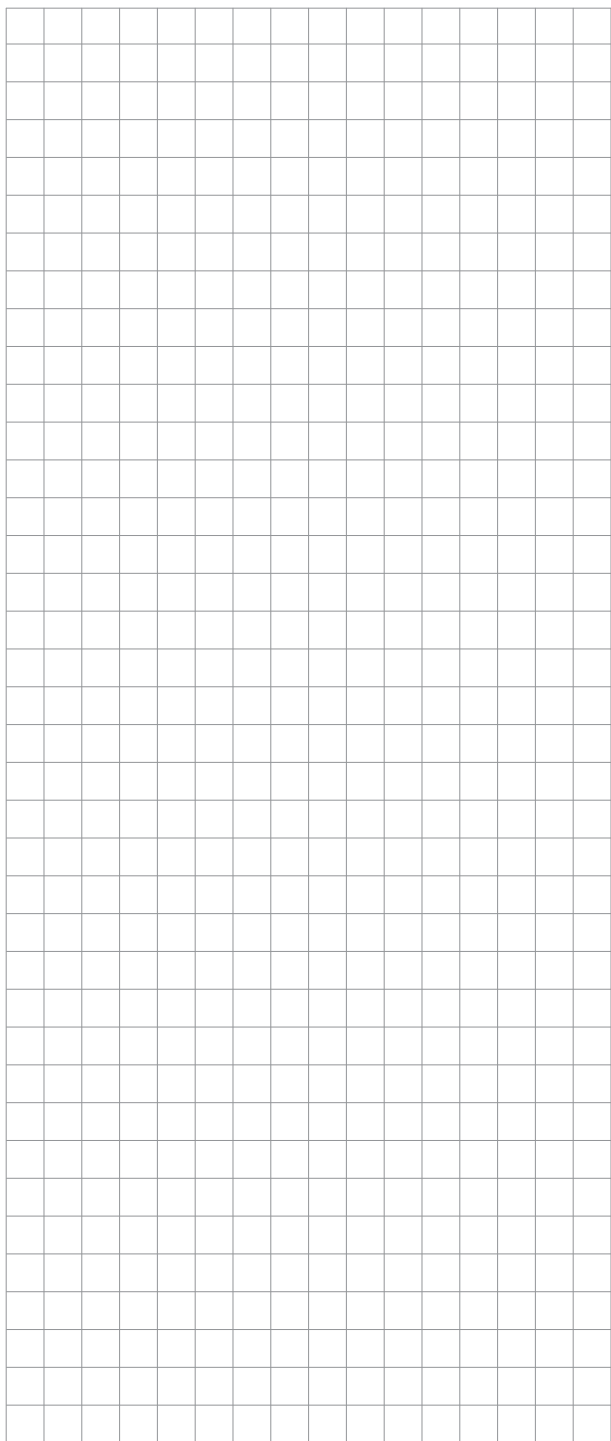

België / Belgique

Tel +32 16 21 35 02
Fax +32 16 21 36 04
SalesBELUX@chemelex.com

Bulgaria

Tel +359 2 973 33 73
SalesEE@chemelex.com

Česká Republika

Tel +420 606 069 618 (Comm)
+420 602 232 969 (Ind)
infoCZ@chemelex.com

Danmark

Tel +45 70 11 04 00
SalesDK@chemelex.com

Deutschland

Tel 0800 181 82 05
SalesDE@chemelex.com

España

Tel +34 911 59 30 60
Fax +34 900 98 32 64
SalesES@chemelex.com

France

Tél 0800 90 60 45
SalesFR@chemelex.com

Hrvatska

Tel +385 51 225 073 (Comm)
+385 1 605 01 88 (Ind)
SalesEE@chemelex.com

Italia

Tel +39 02 577 61 51
Fax +39 02 577 61 55/28
SalesIT@chemelex.com

Lietuva/Latvija/Eesti

Tel +370 698 411 56
SalesEE@chemelex.com

Magyarország

Tel +36 1 253 76 17
SalesHU@chemelex.com

Nederland

Tel 0800 022 49 78
SalesNL@chemelex.com

Norge

Tel +47 66 81 79 90
SalesNO@chemelex.com

Österreich

Tel 0800 29 74 10
SalesAT@chemelex.com

Polska

Tel +48 22 331 29 50
Fax +48 22 331 29 51
SalesPL@chemelex.com

Қазақстан

Tel +7 7112 31 67 03170
SalesKZ@chemelex.com

Serbia and Montenegro

Tel +386 41 665 634 (Comm)
+381 230 439 519 (Ind)
SalesEE@chemelex.com

Schweiz / Suisse

Tel +41 (41) 766 30 80
Fax +41 (41) 766 30 81
infoCH@chemelex.com

Suomi

Puh 0800 11 67 99
SalesFI@chemelex.com

Sverige

Tel +46 31 335 58 00
SalesSE@chemelex.com

Türkiye

Tel +90 545 284 09 05
SalesEE@chemelex.com

UK/Ireland

Tel 0800 969 013
SalesUK@chemelex.com

chemelex
excellence is everything

chemelex.com

Raychem Tracer Pyrotenax Nuheat

©2025 Chemelex. All Chemelex marks and logos are owned or licensed by Chemelex Europe GmbH or its affiliates. All other trademarks are the property of their respective owners. Chemelex reserves the right to change specifications without notice.

RAYCHEM-IM-DOCS17-PolymerInsulated-EN-2507