

Raychem

Self-regulating
and power limiting
heating cable
systems

Installation and Maintenance Manual



1. General information	9
2. Heating cable selection	9
3. Heating cable installation	10
4. Components installation	17
5. Thermostats	23
6. Thermal insulation and marking	24
7. Power supply and electrical protection	26
8. Heating cable testing	26
9. Operation, maintenance and pipe repairs	29
10. Heating cable damage	30
11. Troubleshooting guide	30



Register for your extended warranty on chemelex.com



ATEX/UKEX

	Certificate No	Code
BTV	SGS20ATEX0048X (BAS21UKEX0497X)	Ex II 2 G Ex 60079-30-1 eb IIC T6 Gb Ex II 2 D Ex 60079-30-1 tb IIIC T80°C Db or Ex II 2 G Ex 60079-30-1 eb mb IIC T6 Gb Ex II 2 D Ex 60079-30-1 mb tb IIIC T80°C Db Tmin -60°C
QTVR	SGS20ATEX0050X (BAS21UKEX0498X)	Ex II 2 G Ex 60079-30-1 eb IIC T4 Gb Ex II 2 D Ex 60079-30-1 tb IIIC T130°C Db or Ex II 2 G Ex 60079-30-1 eb mb IIC T4 Gb Ex II 2 D Ex 60079-30-1 mb tb IIIC T130°C Db Tmin -60°C
XTV(R)	SGS20ATEX0049X (BAS21UKEX0499X)	Ex II 2 G Ex 60079-30-1 eb IIC T* Gb Ex II 2 D Ex 60079-30-1 tb IIIC T**°C Db or Ex II 2 G Ex 60079-30-1 eb mb IIC T* Gb Ex II 2 D Ex 60079-30-1 mb tb IIIC T**°C Db Tmin -60°C (* ** see schedule)
KTV	SGS20ATEX0051X (BAS21UKEX0500X)	Ex II 2 G Ex 60079-30-1 eb IIC T226°C(T2) Gb Ex II 2 D Ex 60079-30-1 tb IIIC T226°C Db or Ex II 2 G Ex 60079-30-1 eb mb IIC T226°C(T2) Gb Ex II 2 D Ex 60079-30-1 mb tb IIIC T226°C Db Tmin -60°C (* ** see schedule)
HTV	PTB21ATEX1003X (BAS21UKEX0649X)	Ex II 2 G Ex 60079-30-1 eb IIC T* Gb Ex II 2 D Ex 60079-30-1 tb IIIC T**°C Db or Ex II 2 G Ex 60079-30-1 eb mb IIC T* Gb Ex II 2 D Ex 60079-30-1 mb tb IIIC T**°C Db Tmin -60°C (* ** see schedule)
VPL	SGS20ATEX0045X (BAS21UKEX0503X)	Ex II 2 G Ex 60079-30-1 eb IIC T* Gb Ex II 2 D Ex 60079-30-1 tb IIIC T**°C Db or Ex II 2 G Ex 60079-30-1 eb mb IIC T* Gb Ex II 2 D Ex 60079-30-1 mb tb IIIC T**°C Db Tmin -60°C (* ** see schedule)

IECEx

	Certificate No	Code
BTV	IECEx BAS 20.0011X	Ex 60079-30-1 eb IIC T6 Gb Ex 60079-30-1 tb IIIC T80°C Db or Ex 60079-30-1 eb mb IIC T6 Gb Ex 60079-30-1 mb tb IIIC T80°C Db Tmin -60°C
QTVR	IECEx BAS 20.0013X	Ex 60079-30-1 eb IIC T4 Gb Ex 60079-30-1 tb IIIC T130°C Db or Ex 60079-30-1 eb mb IIC T4 Gb Ex 60079-30-1 mb tb IIIC T130°C Db Tmin -60°C



Certificate No	Code
XTV(R) IECEx BAS 20.0012X	Ex 60079-30-1 eb IIC T* Gb Ex 60079-30-1 tb IIIC T***°C Db or Ex 60079-30-1 eb mb IIC T* Gb Ex 60079-30-1 mb tb IIIC T***°C Db Tmin -60°C (* ** see schedule)
KTV IECEx BAS 20.0014X	Ex 60079-30-1 eb IIC T226°C(T2) Gb Ex 60079-30-1 tb IIIC T226°C Db or Ex 60079-30-1 eb mb IIC T226°C(T2) Gb Ex 60079-30-1 mb tb IIIC T226°C Db Tmin -60°C (* ** see schedule)
HTV IECxPTB21.0007X	Ex 60079-30-1 eb IIC T* Gb Ex 60079-30-1 tb IIIC T***°C Db or Ex 60079-30-1 eb mb IIC T* Gb Ex 60079-30-1 mb tb IIIC T***°C Db Tmin -60°C (* ** see schedule)
VPL IECEx BAS 20.0008X	“Ex 60079-30-1 eb IIC T* Gb Ex 60079-30-1 tb IIIC T***°C Db or Ex 60079-30-1 eb mb IIC T* Gb Ex 60079-30-1 mb tb IIIC T***°C Db Tmin -60°C (* ** see schedule)”



Product name in SAP

Product name in SAP	Certificate No	Code
BTV CABLE	TC RU C-BE. MIO62.B.00054/18	1Ex e IIC T6 Gb X 1Ex e mb II C T6 Gb X Ex tb IIIC T80°C Db X Ex tb mb IIIC T80°C Db X Ta -60°C...+56°C IP66
QTVR CABLE	TC RU C-BE. MIO62.B.00054/18	1Ex e IIC T4 Gb X 1Ex e mb IIC T4 Gb X Ex tb IIIC T130°C Db X Ex tb mb IIIC T130°C Db X Ta -60°C...+56°C IP66
XTV CABLE	TC RU C-BE. MIO62.B.00054/18	1Ex e IIC T* Gb X 1Ex e mb IIC T* Gb X Ex tb IIIC T* Db X Ex tb mb IIIC T* Db X Ta -60°C...+56°C IP66
KTV CABLE	TC RU C-BE. MIO62.B.00054/18	1Ex e IIC 226°C (T2) Gb X 1Ex e mb IIC 226°C (T2) Gb X Ex tb IIIC T226°C Db X Ex tb mb IIIC T226°C Db X Ta -60°C...+56°C IP66
HTV CABLE	EAЭC RU C-BE. AЖ58.B.01728/21	1Ex e mb 60079-30-1 IIC 180°C (T3)...215°C (T2) Gb X Ex tb 60079-30-1 IIIC 180°C ... 215°C Db X
VPL CABLE	TC RU C-BE. MIO62.B.00054/18	1Ex e IIC T* Gb X 1Ex e mb IIC T* Gb X Ex tb IIIC T* Db X Ex tb mb IIIC T* Db X Ta -60°C...+56°C IP66

BSA cables are EAC certified to TR CU 004/2011

Warning: As with any electrical equipment or wiring installation operating at line voltages, heating cable and component damage or incorrect installation that allows the penetration of moisture or contamination can lead to electrical tracking, arcing and potential fire hazard.



Do not connect heating cable conductors together or this will result in a short circuit.

Any unconnected heating cable end must be sealed with a Chemelex approved end seal.

To prevent fire or explosion in hazardous areas, verify that the maximum sheath temperature of the heating cable is below the auto-ignition temperature of the gases in the area. For further information, see design documentation.

The purchaser should make the manufacturer aware of any external effects or aggressive substances that the equipment may be exposed to.

Specific conditions of use

The following limiting temperatures for the end seals, splices and power connections shall not be exceeded:

+110°C for the S-20 and E-20

+260°C for the E-40 and S-40

+150°C for the C-150-E, S-150 and E-150

+151°C for the E-100, E-100-L and JBS-100

+155°C for the JBM-100 and T-100

+110°C for the C25-21 and C25-100

+180°C for the C25-100-METAL/C3/4-100-METAL

The E-100, E-100-L, JBM-100, JBM-100-L, JBS-100, JBS-100-L and T-100 have limiting temperatures based on an internal component in these accessories. When located on a pipe or other work piece surface, a maximum pipe temperature of 250°C will not cause the limiting temperatures of 151°C or 155°C to be exceeded

The end seals, splices and power connections have the following associated ambient temperatures:

–60°C to +56°C for the E-20 and S-20

–60°C to +56°C for the E-40 and S-40

–55°C to +56°C for the T-100, JBM-100, JBS-100, JBU-100 and E-100

–40°C to +56°C for the JBS-100-L, JBM-100-L, and JBU-100-L

–55°C to +55°C for the C-150-E, S-150 and E-150

–40°C to +40°C for the E-100-L

–55°C to +110°C for the C25-21 and C25-100

–60°C to +180°C for the C25-100-METAL / C3/4-100-METAL / C25-100-METAL-NP / C3/4-100-METAL-NP / C25-100-METAL-SS

- The assembly of glands, splices and end terminations shall be carried out in accordance with the manufacturing instructions.
- The heating element supply circuit must include an electrical protection device in conformity with Clause 4.4 of IEC 60079-30-1. For the JBM-100-L, JBU-100-L and JBS-100-L this shall be limited to 20 A maximum when used at ambient temperatures above 40°C.
- The minimum installation temperature of the heating cables is –60°C. The minimum bending radii at specific temperatures are shown on the next pages of this document.
- The supply to the heating unit must be terminated in a suitably certified terminal enclosure.
- At ambient temperatures above 40°C temperature resistant power cable suitable for temperatures above 90°C and metal glands must be used.



- The minimum installation temperature for E-20 and S-20 is -20°C .
- The installer is to carry out a dielectric strength test on Ex equipment in which the C25-21, C25-100 and C25-100-METAL / C3/4-100-METAL / C25-100-METAL-NP / C3/4-100-METAL-NP / C25-100-METAL-SS connection kit is fitted. No dielectric breakdown shall occur. (Alternatively, an insulation resistance test may be undertaken in accordance with IEC 60079-30-2)

Rated Voltage

BTV1, QTVR1, KTV1, XTV(R)1, HTV1, VPL1: 110 V, 120 V

BTV2, QTVR2, KTV2, XTV(R)2, HTV2, VPL2: 230 V, 277 V, VPL4: 400 V, 480 V

	BSA	BTV	QTVR	XTV	XTVR	KTV	HTV	VPL
Min. Bending Radius (mm)								
$-60^{\circ}\text{C} \leq T < -20^{\circ}\text{C}$	35	35	35	51	51	26	25	19
$-20^{\circ}\text{C} \leq T < -10^{\circ}\text{C}$	30	30	30	35	35	20	20	15
$-10^{\circ}\text{C} \leq T < 0^{\circ}\text{C}$	25	25	25	25	25	15	15	15
$0^{\circ}\text{C} \leq T < +10^{\circ}\text{C}$	20	20	20	20	20	15	15	15
$T \geq +10^{\circ}\text{C}$	10	12	12	12	12	12	13	12
Minimum Installation Temperature	-60°C	-60°C	-60°C	-60°C	-60°C	-60°C	-60°C	-60°C

	BSA	BTV	QTVR	XTV	XTVR	KTV	HTV	VPL
Max. continuous operating Temp $^{\circ}\text{C}$ (energized)	65	65	110	121	150	150	205	See table below
Max. intermittent exposure Temp $^{\circ}\text{C}$ (1000 h cumulative, energized/de-energized)	85	85	110	250	***250	250	**260	-
Max. continuous exposure Temp $^{\circ}\text{C}$ (de-energized)	65	65	110	160	160	160	205	260
Self-limiting Temperature in accordance with IEC/EN 60079-30-1		T6	T4	T3 (T2: 20XTV2, 15/20XTV1)	T3* (T2: 15/20XTVR1)	T2	T3 (T2: 20HTV, 28HTV2)	T*
Power Limiting Temperature (*By design)	—	—	—	—	—	—	—	T*

** 2000 hours for HTV, for durations applicable to other exposure temperatures between 205°C and 260°C , contact Chemelex.

*** 2000 hours for XTVR

+ T3 20XTVR2 at max. 240 V



Maximum continuous operating temperature table (heating cable energized)

Cable	110 V	230 V	254 V	277 V	400 V	480 V
5VPL1-CT	235°C	—	—	—	—	—
10VPL1-CT	215°C	—	—	—	—	—
15VPL1-CT	190°C	—	—	—	—	—
20VPL1-CT	150°C	—	—	—	—	—
5VPL2-CT	—	230°C	225°C	225°C	—	—
10VPL2-CT	—	210°C	200°C	195°C	—	—
15VPL2-CT	—	180°C	145°C	105°C	—	—
20VPL2-CT	—	150°C	—	—	—	—
5VPL4-CT	—	—	—	—	230°C	230°C
10VPL4-CT	—	—	—	—	215°C	205°C
15VPL4-CT	—	—	—	—	195°C	160°C
20VPL4-CT	—	—	—	—	150°C	150°C

1. GENERAL INFORMATION

Use of the manual

The Installation and Maintenance manual is for Raychem self-regulating and power limiting heating cable systems on thermally insulated pipes and vessels only.

For information regarding other applications contact your Chemelex representative.

BSA, BTV, QTVR, XTV(R), KTV, HTV self regulating heating cables

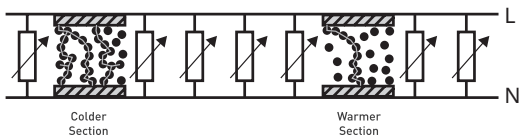

- Power output varies with temperature. As pipe temperature increases, power output decreases.
- At high temperatures, the polymer expands, reducing the number of the conductive paths, and thus reducing current flow.
- At low temperatures, there are many conductive paths, allowing current to flow between the conductors.

VPL power limiting heating cables

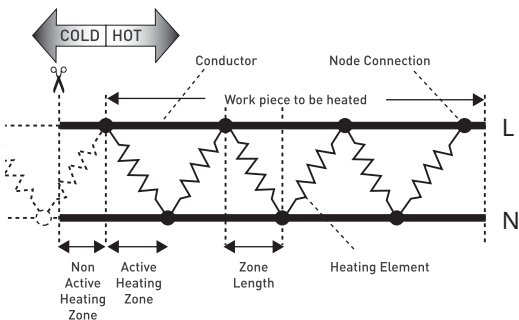

Important

For the Chemelex warranty to apply, the instructions that are included in this manual and product packages must be followed. The installation must be compatible with local requirements applicable to electric heat-tracing systems.

2. HEATING CABLE SELECTION

The design of electrical resistance heat tracing systems shall be overseen by persons knowledgeable of heat tracing following the design methodology for explosive atmospheres as specified by the manufacturer.

Check the design specification to make sure the proper heating cable is installed on each pipe or vessel. Refer to Chemelex product literature and the TraceCalc software to select the proper heating cable for each thermal, chemical, electrical and mechanical environment.

Heat tracing system design documentation

The heat tracing system documentation shall be retained for each heat tracing circuit for as long as the system is in use.



3. HEATING CABLE INSTALLATION

Persons involved in the installation and testing of electric heat tracing systems shall be suitably trained in all special techniques required. Installation shall be carried out under the supervision of a qualified person. De-energise all power circuits before installation or servicing. The insulation resistance of the heating cable shall be measured and recorded after installation and shall not be less than 100 Megaohms.

3.1 Heating cable storage

- Keep ends of heating cable and kit components dry before and during installation
- Temperature range: -40°C to $+60^{\circ}\text{C}$
- Protect the heating cable from mechanical damage

3.2 Pre-installation checks

Check materials received:

- Review the heating cable design and compare the list of materials to the catalogue numbers of heating cables and electrical components received to confirm that proper materials are on site. The heating cable type is printed on its outer jacket.
- Temperature exposure must not exceed that specified in Chemelex product literature. Exceeding these limits will impair product performance. Check that expected exposure is within these limits.
- Ensure that the heating cable voltage rating is suitable for the service voltage available.
- Do not energize cable when it is coiled or on the reel.
- Inspect heating cable and components for in-transit damage. An insulation resistance test (see section 8) on each reel is recommended.

Check piping to be traced:

- Ensure all pressure testing is complete and pipework has final paint coating.
- Walk the system and plan the routing of the heating cable on the pipe.
- Check pipework against specification drawing. If different consult design authority.
- Inspect piping for burrs, rough surfaces, sharp edges etc. which could damage the heating cable. Smooth off or cover with layers of glass cloth tape or aluminium foil.

3.3 Heating cable handling

Heating cable handling tips:

- Paint and pipe coatings must be dry to the touch before heating cable installation.
- When pulling the heating cable, avoid:
 - sharp edges
 - excessive pulling force
 - kinking and crushing
 - walking on it, or running over it with equipment

Heating cable pulling tips:

- Use a reel holder that pays out smoothly with little tension.
- Keep heating cable strung loosely but close to the pipe being traced to avoid interference with supports and equipment.
- Pay out designed length and mark (i.e. with fixing tape) on cable while still on reel.

- Leave the appropriate amount of heating cable at all power connection, splice, tee and end seal locations. (Refer to component installation instructions)
 - Add additional heating cable to trace the fittings and supports or for spiralling as required by the design specifications, or consult Chemelex product literature for design.
- Protect all heating cable ends from moisture, contamination and mechanical damage or other interference if left exposed before component installation.

3.4 Heating cable attachment recommendations

- The heating cable may be installed straight, spiralled or in multiple runs as required by the design specification, Chemelex product literature or TraceCalc software.
 - Do not use metal attachments, vinyl electrical tape or duct tape as heating cable damage may result.
 - Self-Regulating technology allows for the multiple overlapping of the heating cable on to itself.
- Power Limiting technology dictates that the heating cable can be overlapped only once on to itself. If VPL cables are installed parallel to each other, please allow for minimum 15 mm clearance.

For VPL heating cable only:

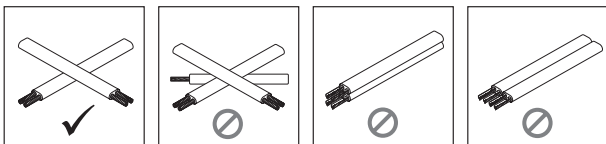

- Fix in place with a minimum of two wraps the appropriate self-adhesive glass cloth tape (see figure 1) or plastic cable ties at 300 mm intervals and additionally where necessary.
- Plastic cable ties must have a temperature rating that matches the system exposure temperature.
- The heating cable's minimum bend radius must not be exceeded (refer to p. 6)

Bend the cable only in upright position

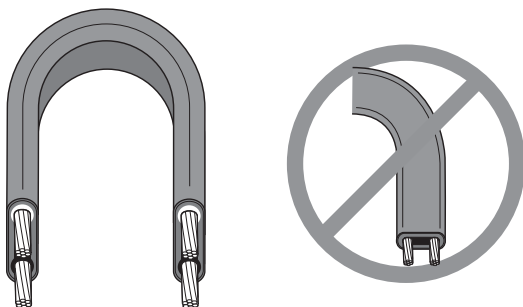

- The heating cable does not bend easily in the flat plane. Do not force such a bend, as the heating cable may be damaged.

3.4.1 Straight tracing

- Straight trace the pipe unless the design calls for spiralling (see 3.4.2).
- On horizontal pipes fix on lower quadrant as shown in Figure 1 and not on bottom of pipe.



- To prevent overheating, be sure the location of the power limiting heating cable is planned so that the active heating zone will not extend into the component. Read the kit installation instructions and plan the component location before permanently attaching the cable to the pipe. Ensure that the active heating zones are located where heat is required i.e. on the pipe.
- Thermally insulate and weatherproof to specification.

Figure 1

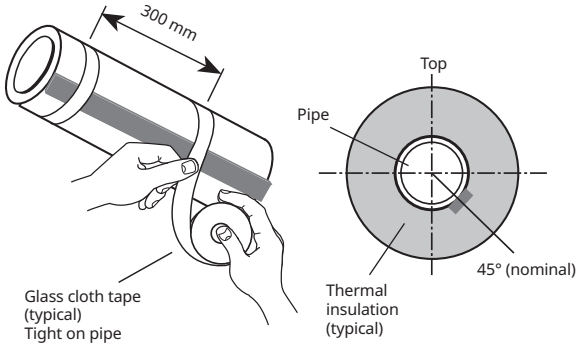

Chemelex attachment tapes:

- GT66 Self-adhesive glass cloth tape
General purpose tape. Not for stainless-steel surfaces or for installation temperatures $<4^{\circ}\text{C}$.
- GS54 Self-adhesive glass cloth tape
Recommended for use on stainless-steel and cupro-nickel surfaces or for installation temperatures $<4^{\circ}\text{C}$.

Figure 2

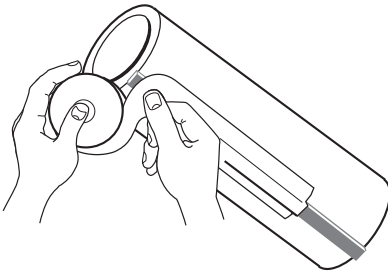

ATE-180 Aluminium tape

Use only if the design requires it.

ATE-180 improves the heat transfer and increases the power output of the heating cable.

Attach the heating cable to the pipe as shown in Figure 2.

3.4.2 Spiraling tracing

- Alternative spiralling methods are shown in Figures 2a and 2b.
- Only spiral heating cable on pipe when called for by design.
- To prevent overheating, be sure the location of the power limiting heating cable is planned so that the active heating zone will not extend into the component. Read the kit installation instructions and plan the component location before permanently attaching the cable to the pipe. Ensure that the active heating zones are located where heat is required i.e. on the pipe.

Spiral pitch table (mm).

NB (mm)	NPS (inches)	Spiral Ratio				
		1.1	1.2	1.3	1.4	1.5
25	1	250	170	140	110	100
32	1¼	310	210	170	140	130
40	1½	350	240	190	160	140
50	2	430	300	240	200	180
65	2½	520	360	290	240	210
80	3	630	430	350	290	260
90	3½	720	490	390	330	290
100	4	800	560	440	370	330
125	5	990	680	550	460	400
150	6	1180	810	650	550	480
200	8	1520	1050	840	710	620

Example:

For pipe of 80 mm NB (3" NPS) requiring 1.3 metres of heating cable per metre of pipe, pitch is 350 mm.

Figure 2a

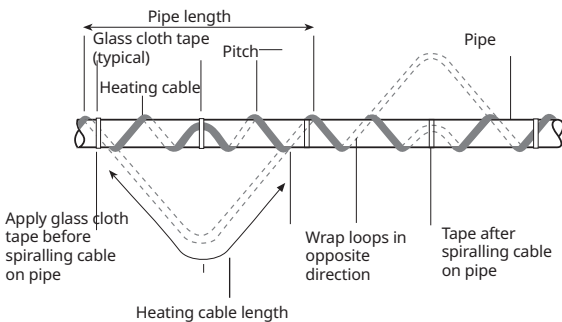

Heating cable length = pipe length x spiral ratio

Refer to design specification for spiral ratio

- Step 1 Make starting loop as shown
- Step 2 Grasp loop and wind around pipe
- Step 3 Space evenly and attach to pipe.
Thermally insulate and weatherproof to specification

Figure 2b

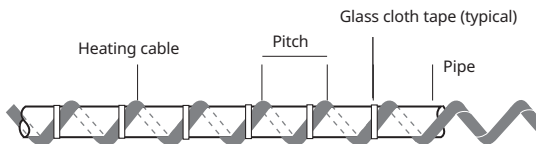

Refer to design specification for spiral pitch

Mark the pipe at the spiral pitch or use a simple length gauge

Fix the heating cable as installation progresses

Thermally insulate and weatherproof to specification



3.5 Cutting the heating cable

- Cut the heating cable to length after it is attached to the pipe. Before cutting it, confirm the tracing allowance as per Sections 3.3 and 3.6.
- Raychem heating cable can be cut to length without affecting the heat output per metre.

3.6 Typical installation details

- Typical installation details for fixing heating cable to pipe fittings are shown hereafter.

General notes:

- Trace pipe fittings as shown to allow easy maintenance.
- Consult the design specification or Chemelex product literature or TraceCalc software for the tracing requirements for fittings and supports.
- Follow the recommendations for cutting and stripping heating cables; they are included in the component installation instructions.

3.6.1 Valve

Figure 3

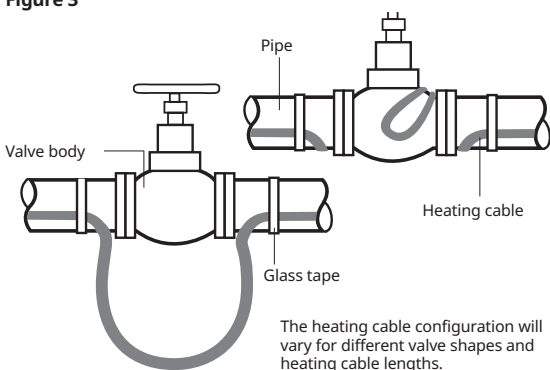

- Refer to design specification for additional heating cable length.
- Fix with self-adhesive glass cloth tape.
- Thermally insulate and weatherproof to specification (including valve stem).

3.6.2 Elbow

Figure 4

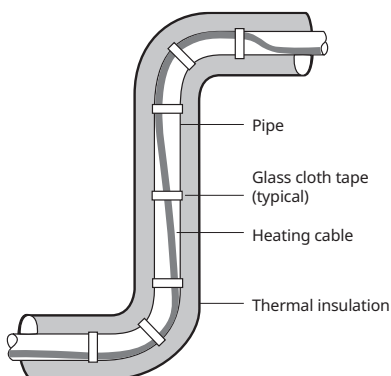

- Fix heating cable to outside (long) radius of elbow
- Fix with self-adhesive glass cloth tape
- Thermally insulate and weatherproof to specification

3.6.3 Flange

Figure 5

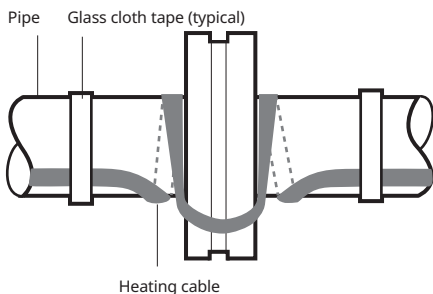

- Additional heating cable is 2-3 times diameter of pipe (typical)
- Fix with self-adhesive glass cloth pipe
- Thermally insulate and weatherproof to specification

3.6.4 Pipe bar hanger

Figure 6

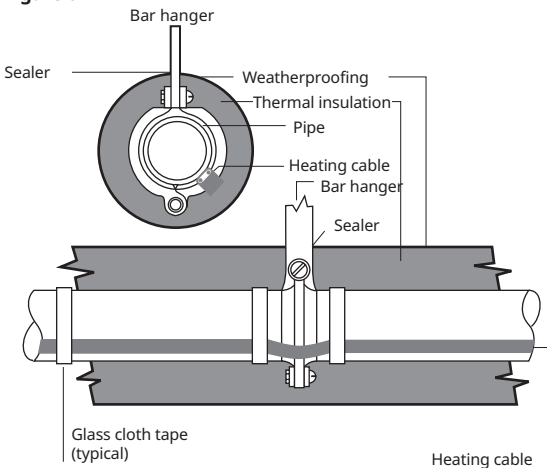

- Do not clamp heating cable with support. Heating cable must be over the support
- No additional heating cable is required for bar or rod pipe hangers unless called for in the design specification, then use loop length specified
- Fix with self-adhesive glass cloth tape
Thermally insulate and weatherproof to specification



3.6.5 Pipe support shoe

Figure 7
Side view

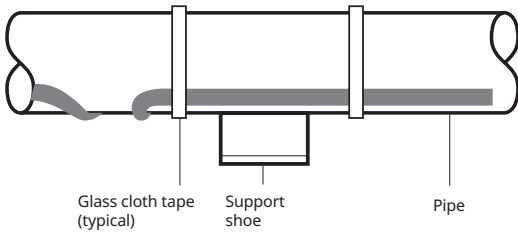

Bottom view

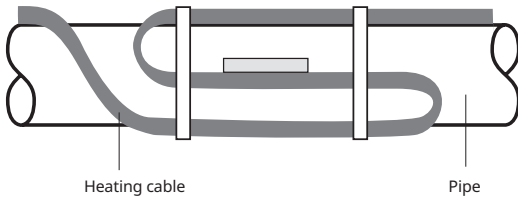

- Refer to design specification for additional heating cable length
- Fix with self-adhesive glass cloth tape
- Thermally insulate and weatherproof to specification

General notes:

Select the required components from Chemelex product literature or use the TraceCalc software.

Raychem component kits (including power connections, splices and end seals) must be used to satisfy Standards and Approval Body requirements.

Installation instructions included in the kit must be followed, including those for preparation of the heating cable conductors for connections. Before assembly, use the guide given in the instructions to ensure that the kit is correct for the heating cable and environment.

- Raychem self-regulating and power limiting heating cables are parallel circuit design. Do not twist the conductors together as this will result in a short circuit.

4.1 Components required

- For the installation of all components refer to the relevant component installation instructions.
- Required for each heating cable run:
Power connection and insulation entry kit
End seal.
- As required:
Splice. Tee-splice. Junction box. Three connection kits and three insulation entry kits. Accessories (pipe straps, fixing tape, support brackets, labels, etc.).



4.2 Typical systems installation

Below components are not suitable for BSA. You can find the solutions for BSA in DOC2210 or contact your local Chemelex representative.

Figure 8a

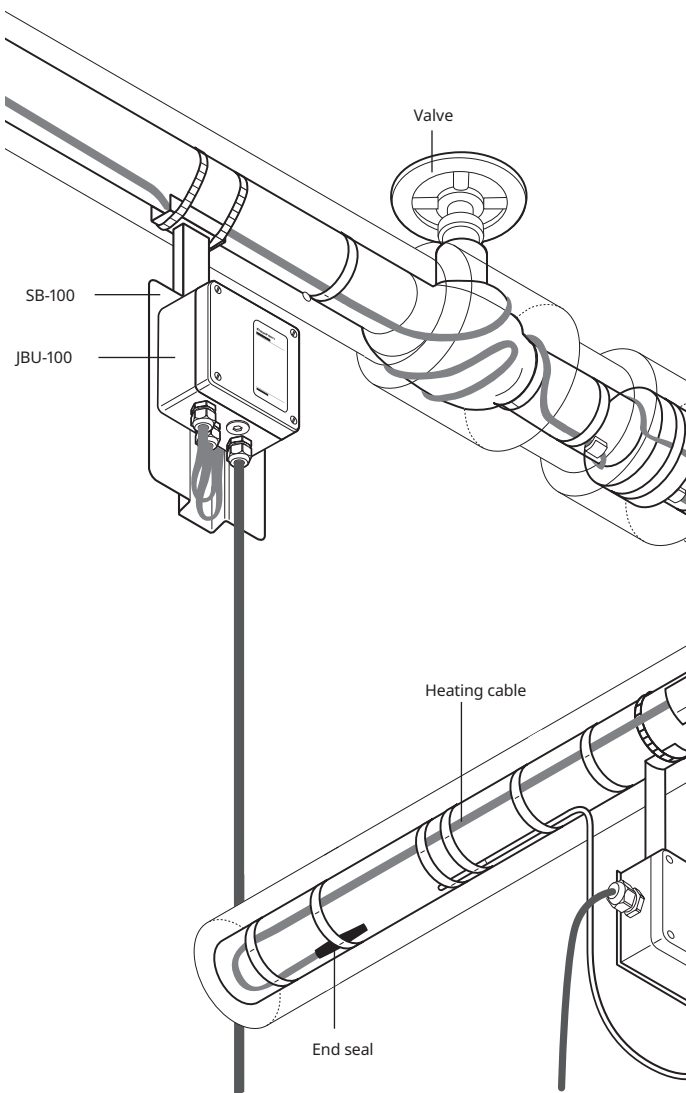

Wallmounted

IEK-25-04
Insulation entry kit

JBU-100
Junction box for
modular system

C25-100
Connection kit

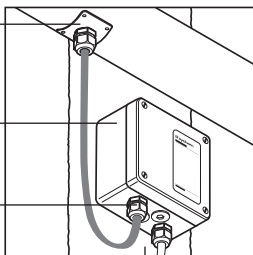

Heating
cable

Splice (as required)

Thermal insulation

Glass cloth tape
(typical)

Insulation
Entry kit

SB-101

Thermostat

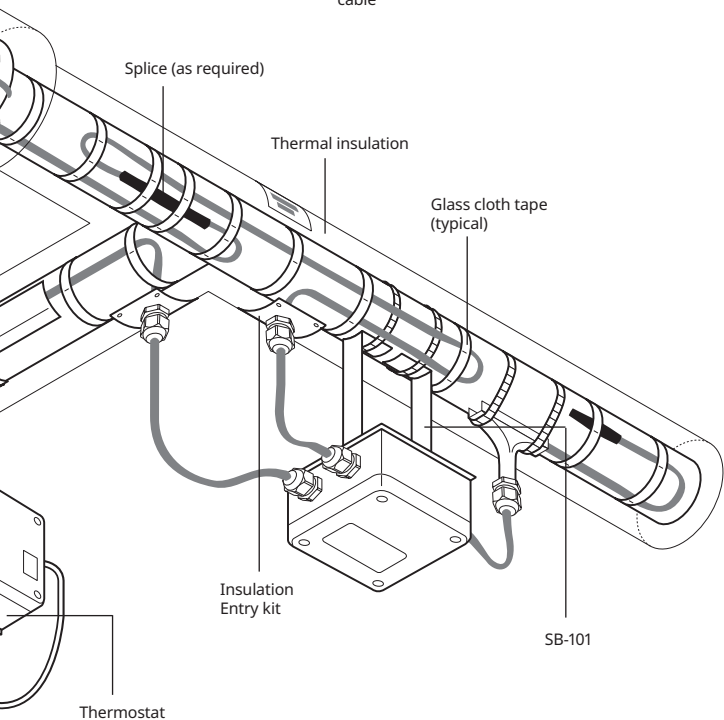
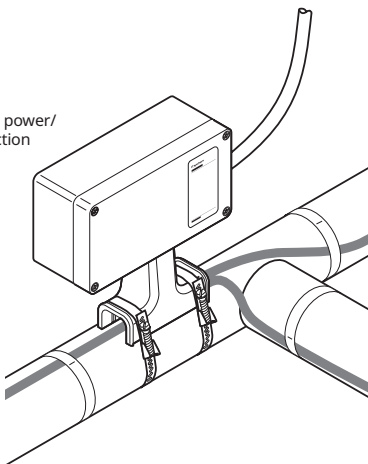



Figure 8b

JBM-100
Integrated power/
tee connection



T-100
Tee or splice
connection

JBS-100
Integrated power connection
(shown with light)

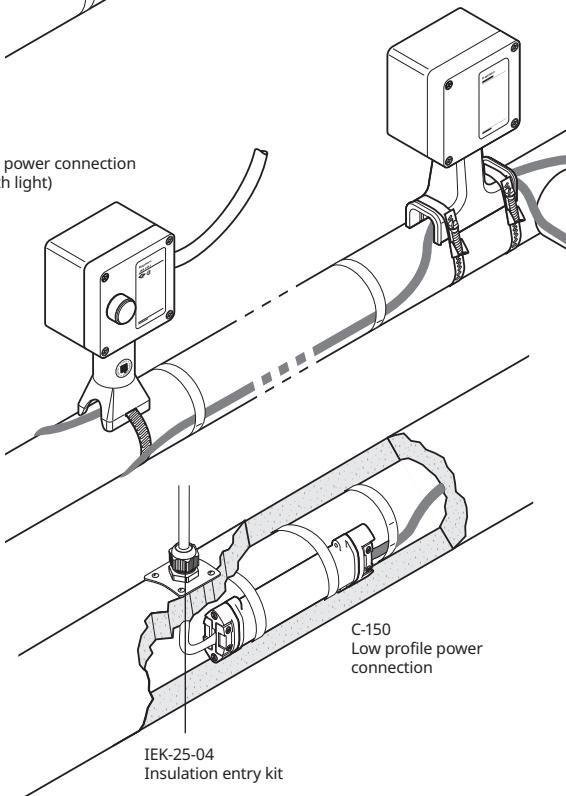

C-150
Low profile power
connection

IEK-25-04
Insulation entry kit



E-100-L
Lighted end seal

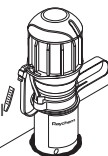

E-100
End seal

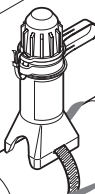

S-150
Low profile splice

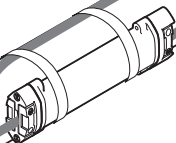

E-150
Low profile
end seal

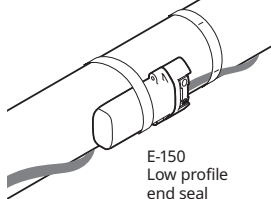



4.3 Component installation hints

- On horizontal pipes locate junction boxes below pipe wherever possible. Pinch out drainhole in the stand when installing upside down.
- Locate junction boxes for easy access but not exposed to mechanical abuse.
- Position junction boxes so that power cable and heating cable entries do not point upwards.

Figure 9a

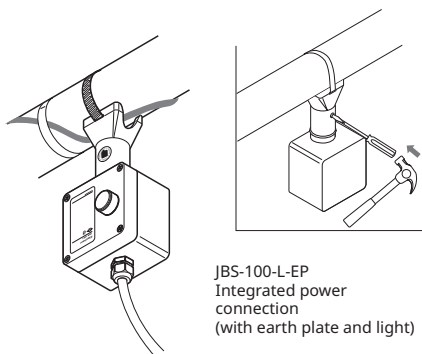

- Fix lids in place where access not required.
- Confirm junction box stopping plugs are correct for application and fixed firmly in place.
- Route heating cable from junction box to insulation entry so as to avoid possible mechanical damage.
 - Do not strain heating cable as it exits/enters junction boxes and insulation entries.
- Ensure heating cable is fixed above pipe straps such as used for junction box support brackets.
- Fix all low profile components (e.g. heatshrink end seals) in place with self-adhesive glass cloth tape.

5. THERMOSTATS

- In temperature-sensitive applications, thermostatic control may be necessary. If maximum temperature is a concern, consult your Chemelex representative for design assistance.
- Raychem control and monitoring products are designed for use with Self-Regulating and Power-Limiting heat-tracing systems. Thermostats, controllers and control and monitoring systems are available. Compare features of these products in the table below. For additional information on each product, refer to product datasheets or contact your Chemelex representative.
- Follow the installation instructions supplied with the thermostat. Use the proper wiring diagram for the heating cable layout and control method desired.

	Mechanical Thermostats	ETS-05	NGC-20	Elexant 40x0i	NGC-30	NGC-40
Control						
Ambient sensing	X	X	X	X	X	X
Line sensing	X	X	X	X	X	X
Pasc			X	X	X	X
Monitoring						
Ambient temperature		X	X	X	X	X
Pipe Temperature		X	X	X	X	X
Ground Fault			X	X	X	X
Current			X	X	X	X
Voltage			X	X	X	X
Location						
Pipe mount		X	X	X		
Field Mount		X	X	X	X	X
Substation				X	X	X

- Controllers shall meet the requirements from clause 4.5.3 in IEC/IEEE 60079-30-1.



6. THERMAL INSULATION AND MARKING

6.1 Pre-insulation checks

- Visually inspect the heating cable and components for correct installation and damage. (See Section 10 if damaged.)
- Insulation resistance (Megger) testing (as per Section 8) is recommended prior to covering the pipe with thermal insulation.

6.2 Insulation installation hints

- Correct temperature maintenance requires properly installed and dry thermal insulation.
- Thermally insulate and weatherproof to design specification.
- Check insulation type and thickness against the design specification.
- To minimize potential heating cable damage, insulate as soon as possible after tracing.
- Check that all pipework, including fittings, wall penetrations and other areas, have been completely insulated.
- Ensure that heating cable is not damaged during installation of cladding for example by drills, self tapping screws and sharp edges of cladding.
- Check that all insulation entry kits are fitted correctly and sealed.
- Ensure that all places where valve stems, support brackets, thermostat capillaries, etc exit the cladding are sealed.

6.3 Marking

- For power limiting heating cable install label: LAB-I-35 as shown (typical) in figures 10a & 10b

Figure 10a

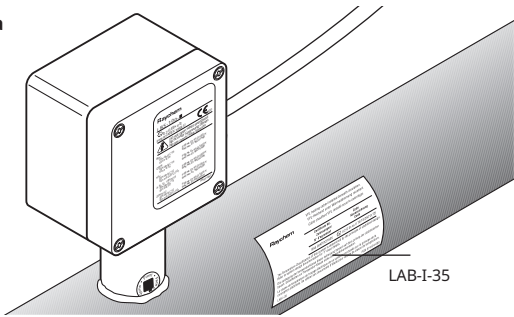
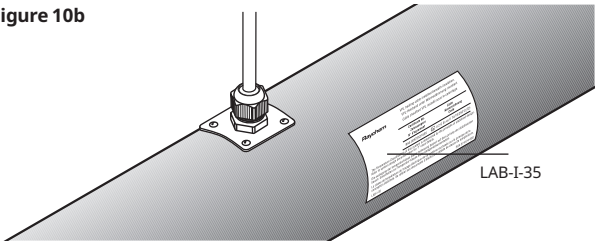
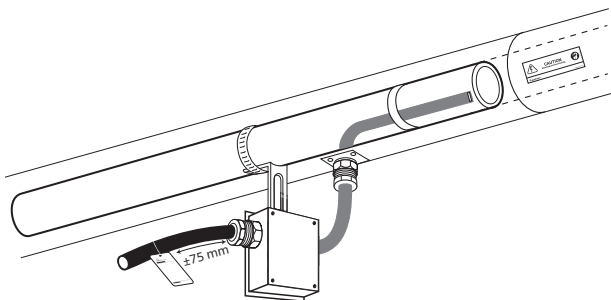

Figure 10b



- The presence of the heating cables shall be made evident by the posting of warning labels or caution labels (“Electric Traced”) on the cladding. Labels are to be applied at maximum 3 meter intervals and on alternate locations along the circuit.
- Install “Electric Traced” signs along piping at suitable intervals (3 m intervals recommended) on alternate sides as a warning.
- Mark on outside of insulation the location of heating cable components.

Figure 10c





7. POWER SUPPLY AND ELECTRICAL PROTECTION

In the event of an earth fault or over current interruption, the device shall not be reset until the cause of the trip has been investigated by qualified personnel.

7.1 Electrical loading

Size overcurrent protective devices according to the design specification or applicable Chemelex product literature. If devices other than those specifically identified are used, consult the Chemelex representative for the appropriate sizing information.

7.2 Ground fault equipment protection is required for each circuit

The metal sheath/braid of the heating cable must be connected to a suitable earthing terminal.

7.3 Residual current (earth fault) protection

Chemelex insists on the use of a 30 mA residual current device to provide maximum safety and protection. However, where there is a marked increase in nuisance tripping, a maximum 300 mA residual current device may be used.

For heating cables installed in a hazardous area, the use of residual current devices is normally a condition of their approval.

8. HEATING CABLE TESTING

8.1 Recommendations

Chemelex recommends insulation resistance test before installing heating cable; before installing thermal insulation; prior to initial start-up; and as part of the periodic maintenance. (see Section 9.2).

8.2 Test method

After completing heating cable installation, the insulation resistance between the conductors and the braid should be checked (see Figure 11) using a 2500 VDC megger. Minimum readings should be 100 MegaOhms regardless of the heating cable length. The installer should record the original values for each circuit on the installation record sheet (see page 33). If a thermostat is installed, it should be bypassed.

Figure 11

Test between heating cable and braid

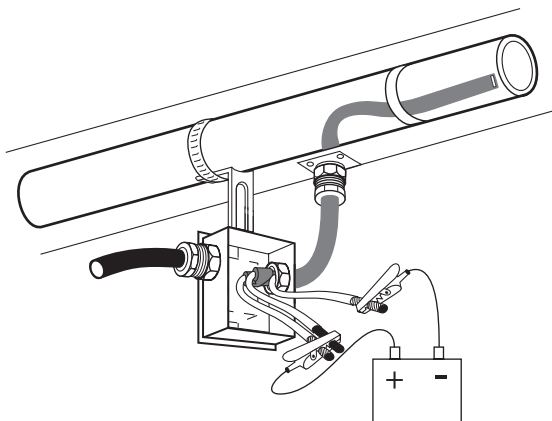

Capacitance test method

This method uses capacitance measurement (nF) to approximate the location of a fault where the heating cable has been severed. It also gives an estimate of total heating cable length in a non-severed circuit. This reading must be taken at the power connection and will only work when the heating cable has passed IR testing. This information is used to calculate the heating cable output per linear metre or to determine if the maximum length has been exceeded.

Record the capacitance reading from one end of the heating cable. The capacitance reading should be measured between both bus wires twisted together (positive lead) and the braid (negative lead).

Multiply the measured capacitance with the heating cable's capacitance factor as listed in the following table.

Example:

20HTV2-CT

Recorded capacitance = 16.9 nF

Capacitance factor = 2.96 m/nF

Fault location = 16.9 nF x 2.96 m/nF
= 50 m from reading location

As an alternative, capacitance values from both the front and back end can be used. The ratio of one capacitance value taken from one end (A) divided by the sum of both A and B (A + B) and then multiplied by 100 yields the distance from the first end, expressed as a percentage of the heating circuit length.



Heating cable capacitance factors (m/nF)

Cable catalog number	Capacitance factor	Cable catalog number	Capacitance factor
3BTV1-CR	2.29	20XTVR2-CT	2.71
3BTV2-CT	2.29	5XTVR1-CT	3.08
5BTV1-CR	2.29	10XTVR1-CT	2.68
5BTV2-CT	2.29	15XTVR1-CT	2.68
8BTV1-CR	1.68	20XTVR1-CT	2.77
8BTV2-CT	1.68	5KTV1-CT	3.29
10BTV1-CR	1.68	5KTV2-CT	3.38
10BTV2-CT	1.68	8KTV1-CT	3.14
10QTVR1-CT	1.43	8KTV2-CT	3.2
10QTVR2-CT	1.43	15KTV1-CT	2.96
15QTVR2-CT	1.01	15KTV2-CT	3.02
15QTVR1-CT	1.01	20KTV1-CT	2.83
20QTVR1-CT	1.01	20KTV2-CT	3.08
20QTVR2-CT	1.01	3HTV1-CT	3.2
4XTV2-CT-T3	3.29	3HTV2-CT	3.51
5XTV1-CT-T3	3.29	5HTV1-CT	3.2
5XTV2-CT-T3	3.38	5HTV2-CT	3.38
8XTV2-CT-T3	3.38	8HTV1-CT	2.80
10XTV1-CT-T3	3.14	8HTV2-CT	3.38
10XTV2-CT-T3	3.26	10HTV1-CT	2.8
12XTV2-CT-T3	3.26	10HTV2-CT	3.2
15XTV1-CT-T3	2.96	12HTV1-CT	2.93
15XTV2-CT-T3	3.02	12HTV2-CT	3.14
20XTV1-CT-T2	2.83	15HTV1-CT	2.83
20XTV2-CT-T2	3.08	15HTV2-CT	2.99
3XTVR2-CT	3.57	20HTV1-CT	2.65
5XTVR2-CT	3.51	20HTV2-CT	2.96
8XTVR2-CT	3.11	28HTV2-CT	2.56
10XTVR2-CT	3.20	All VPL-CT	2.86
12XTVR2-CT	2.99		
15XTVR2-CT	2.87		

9. OPERATION, MAINTENANCE AND PIPE REPAIRS

Caution: Consult the heat tracing system documentation prior to maintenance/repair/modification.

9.1 Heating cable operation

- Temperature exposure must not exceed that specified in Chemelex product literature. Exceeding those limitations will shorten the service life and may permanently damage the heating cable.
- Pipe insulation must be complete and dry to maintain the correct temperature.

9.2 Inspection and maintenance

- Visual inspection: Exposed heating cable and pipe insulation should be checked periodically to make sure that no physical damage has occurred.
- Upon completion of maintenance/repair/modification, the insulation resistance of the heating cable shall be measured and recorded and shall not be less than 100 Megaohms
- Meggering: The system should be meggered regularly. When meggering the insulation resistance from the main supply panel, it is recommended that the test is performed between L/N (together) and PE. Freeze protection systems should be meggered before the winter months each year (see section 8). Temperature maintenance systems should be tested at least twice a year. Function testing of electrical protection and temperature control systems should be carried out at regular intervals.
- The Periodic Inspection Record on the following pages should be filled out during maintenance of each circuit in your system.

9.3 Piping systems repair and maintenance

- After maintenance/repair/modification, test the operation of the earth-fault device of each affected circuit or equivalent.
- Isolate heating cable circuit.
- Protect the heating cable from mechanical or thermal damage during pipe repair work.
- Check heating cable installation after pipe repairs and restore thermal insulation following the recommendations in Section 6. Check correct functioning of electrical protection systems.



10. HEATING CABLE DAMAGE

- Do not repair damaged heating cable.
Remove entire damaged section and splice in a new length using the appropriate Raychem splice kits.
- Replace damaged heating cable at once.
Damage allowing moisture and contamination to enter the heating cable may result in arcing earth faults and potential fire hazards.
- Heating cable exposed to fire or flame may cause further fire damage if powered.
Remove from service at once and replace before re-use.

11. TROUBLESHOOTING GUIDE

- Refer to the Troubleshooting guide on pages 34–37.
If the problem persists after following the guide procedures, contact your Chemelex representative immediately.

INSPECTION AND MAINTENANCE RECORD SHEET

CIRCUIT NO.		MONTH:			YR.:		
MAINTENANCE CHECKS FOR:							
No signs of overheating, moisture, or corrosion, etc.	Initial						
	Date						
In connection systems Heating cable and cable glands tight Connection terminals tight Earth connection tight Insulation in good condition	Initial						
	Date						
Thermostats set properly and capillaries are protected	Initial						
	Date						



Troubleshooting guide

A Symptom: Overcurrent protection trips or blows
Probable Causes:

- 1 Electrical fault at
 - a damaged heating cable
 - b faulty splices or tees
 - c end seal
 - d connection
-

2 Circuit oversized

3 Start-up below design temperature

4 Defective electrical protection

B Symptom: RCD trips

Probable Causes:

- 1 Earth fault at:
 - a damaged heating cable
 - b faulty splices or tees
 - c end seal
 - d connection
-

- 2 Excessive moisture in:
 - a junction boxes
 - b splices and tees
 - c end seals
-

3 High leakage currents due to a combination of excessive lengths of power cable and heating cable.

4 Mains borne disturbances

5 Defective RCD

Corrective Actions

- 1 Investigate and remedy (see note 1):
- 2 Resize or redesign within Technical Databook Guidelines. (If larger protection is required, ensure supply cables are compatible).
- 3
 - a redesign for lower start-up temperatures
 - b preheat pipe from alternative heat source to within exposure temperatures given in Product Data Sheets
 - c Energize part of circuit followed by remainder (e.g. in sequence)
- 4 Replace

Corrective Actions

- 1 Investigate and remedy (see note 1):
 - 2 Dry out and reseal or remake immediately. Perform insulation resistance test. (10 MΩ minimum)
 - 3 Redesign
 - 4 Redesign distribution, guidance is available from Chemelex
 - 5 Replace
-



C Symptom: No power output.
Probable Causes

- 1 Loss of supply voltage due to:
 - a overcurrent or residual current protection operating
 - b loose terminals in junction box
 - c loss of supply cable continuity (e.g., open circuited from damage)
-

- 2 Control thermostat is connected in the normally open position

- 3 High resistance connection at:
 - a junction box terminals
 - b splices and tees
-

D Symptom: Low pipe temperature.
Probable Causes:

- 1 Wet thermal insulation

- 2 Design error

- 3 Incorrect setting or operation of controls e.g., thermostats.

- 4 Heating cable has been exposed to excessive temperature beyond rating.

Note:

Locate faults by the following steps:

1. Visually inspect the power connections, splices and end seals for correct installation.
2. Look for signs of damage at:
 - a) Valves, pumps, flanges and supports.
 - b) Areas where repairs or maintenance work has been carried out.
3. Look for crushed or damaged insulation and cladding along the pipe.

Corrective Actions

-
- 1 Restore supply voltage
 - a following A and B (page 29)
 - b re-tighten terminals
NB: If excessive heating has occurred due to high resistance, replace terminals or crimps
 - c locate damage and repair
 - 2 Reconnect to normally closed position
-

- 3 Locate and remedy by:
 - a re-tighten
 - b repair
NB: If excessive heating has occurred due to high resistance, replace terminals or crimps
-

Corrective Actions

-
- 1 Remove and replace with dry insulation of correct specification and ensure complete weatherproofing
 - 2
 - a check with competent authority for design conditions
 - b modify to meet Chemelex recommendations
 - 3 Repair or reset to correct level of operation
 - 4 Replace
-

4. If after 1, 2 and 3 above the fault has not been located, then either:
 - a) Consult Chemelex for further assistance.
 - b) Where local practices and conditions allow (e.g., non hazardous areas) isolate one section of heating cable from another by cutting in half and testing (e.g., Insulation Resistance) both halves until general area of damage is found. Remove insulation and expose fault.

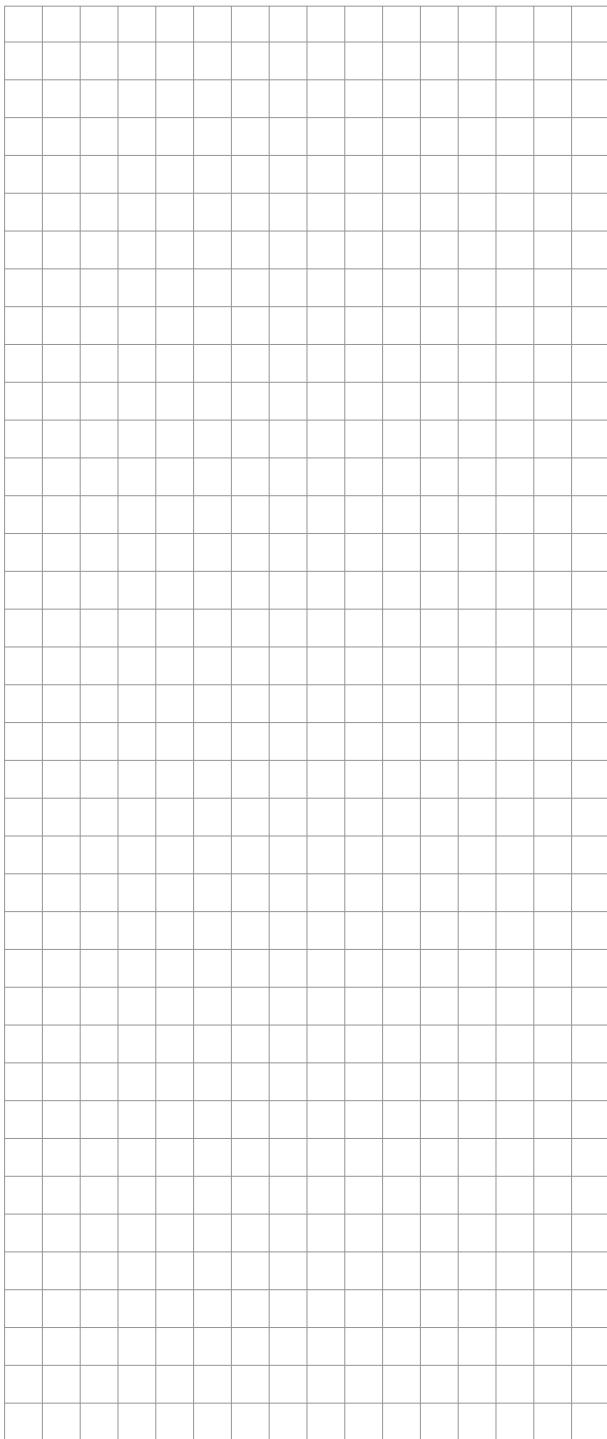

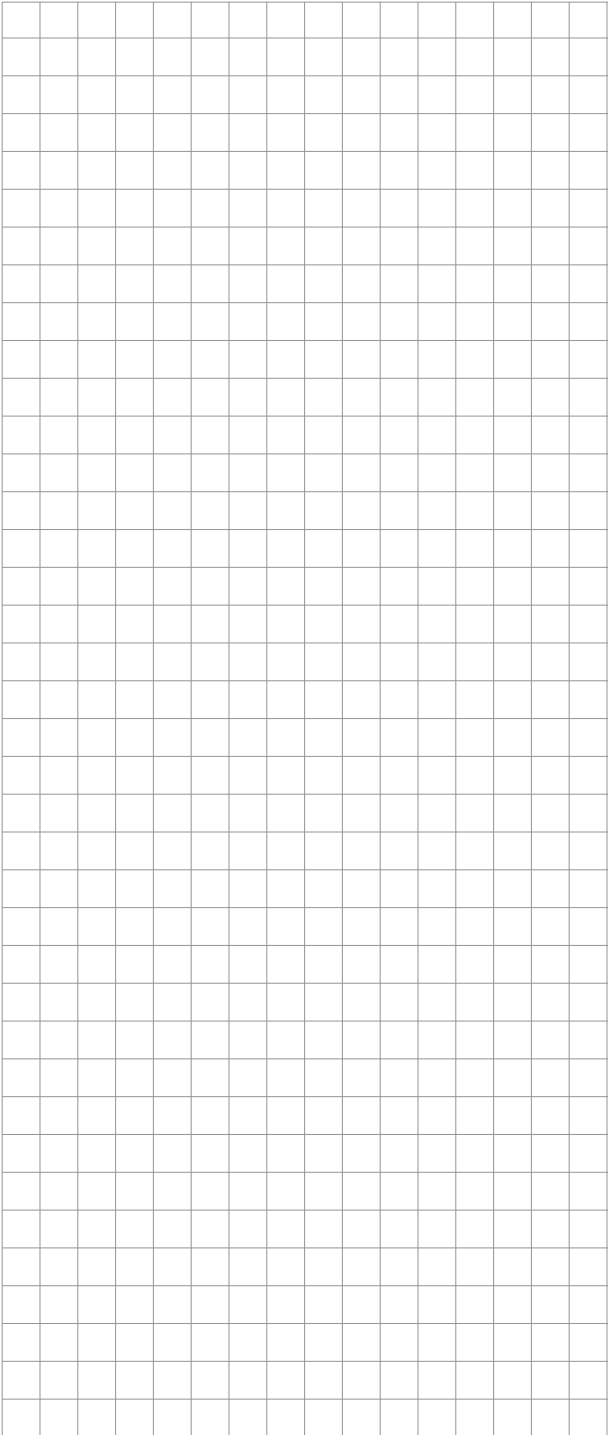

België / Belgique

Tel +32 16 21 35 02
Fax +32 16 21 36 04
SalesBELUX@chemelex.com

Bulgaria

Tel +359 2 973 33 73
SalesEE@chemelex.com

Česká Republika

Tel +420 606 069 618 (Comm)
+420 602 232 969 (Ind)
infoCZ@chemelex.com

Danmark

Tel +45 70 11 04 00
SalesDK@chemelex.com

Deutschland

Tel 0800 181 82 05
SalesDE@chemelex.com

España

Tel +34 911 59 30 60
Fax +34 900 98 32 64
SalesES@chemelex.com

France

Tél 0800 90 60 45
SalesFR@chemelex.com

Hrvatska

Tel +385 51 225 073 (Comm)
+385 1 605 01 88 (Ind)
SalesEE@chemelex.com

Italia

Tel +39 02 577 61 51
Fax +39 02 577 61 55/28
SalesIT@chemelex.com

Lietuva/Latvija/Eesti

Tel +370 698 411 56
SalesEE@chemelex.com

Magyarország

Tel +36 1 253 76 17
SalesHU@chemelex.com

Nederland

Tel 0800 022 49 78
SalesNL@chemelex.com

Norge

Tel +47 66 81 79 90
SalesNO@chemelex.com

Österreich

Tel +0800 29 74 10
SalesAT@chemelex.com

Polska

Tel +48 22 331 29 50
Fax +48 22 331 29 51
SalesPL@chemelex.com

Казакстан

Tel +7 7112 31 67 03170
SalesKZ@chemelex.com

Romania

Tel +40 344 801 140
SalesEE@chemelex.com

Serbia and Montenegro

Tel +386 41 665 634 (Comm)
+381 230 439 519 (Ind)
SalesEE@chemelex.com

Schweiz / Suisse

Tel +41 (41) 766 30 80
Fax +41 (41) 766 30 81
infoCH@chemelex.com

Slovensko

Tel +420 606 069 618 (Comm)
+420 602 232 969 (Ind)
SalesEE@chemelex.com

Slovenija

Tel +386 41 665 634
SalesEE@chemelex.com

Suomi

Puh 0800 11 67 99
SalesFI@chemelex.com

Sverige

Tel +46 31 335 58 00
SalesSE@chemelex.com

Türkiye

Tel +90 545 284 09 05
SalesEE@chemelex.com

UK/Ireland

Tel 0800 969 013
SalesUK@chemelex.com

chemelex

excellence is everything

chemelex.com

Raychem Tracer Pyrotenax Nuheat

©2025 Chemelex. All Chemelex marks and logos are owned or licensed by Chemelex Europe GmbH or its affiliates. All other trademarks are the property of their respective owners. Chemelex reserves the right to change specifications without notice.

RAYCHEM-IM-DOC71-SelfRegHeatingCable-EN-2504

PCN: 481825-000