

PMKG-LT

Low-Profile Tee Connection Kit Installation Instructions

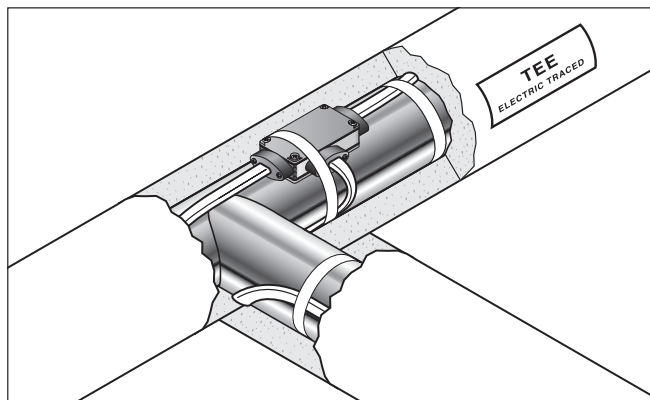

APPROVALS

Hazardous Locations



BTV-CR, BTV-CT, QTVR-CT and LBTV2-CT heating cables only

Class I, Div. 2, Groups A, B, C, D
Class II, Div. 2, Groups F, G
Class III

Nonhazardous Locations



KHP-CR heating cables only

KIT CONTENTS

| Item | Qty | Description |
|------|-----|---------------------------------------|
| A | 1 | Body |
| B | 3 | Pressure plates with captive screws |
| C | 3 | Red grommets (not for use with LBTV2) |
| D | 2 | Gaskets |
| E | 2 | Covers with captive screws |
| F | 1 | Label |

Description

The Raychem PMKG-LT is a NEMA Type 4X rated tee kit designed for use with Raychem BTV-CR, BTV-CT, QTVR-CT, LBTV2-CT, and KHP-CR parallel heating cables. It is designed to be placed on the pipe, under the insulation and cladding.

For additional information contact your Chemelex representative or call (800) 545-6258.

Tools Required

- Wire cutters
- Needle-nose pliers
- Screwdriver
- Utility knife

Additional Materials Required

- Three grommets: (1)
PMK-GK-10 P/N 222724-000 (Package of ten grommets)
 - Glass cloth tape
 - GT-66 Installation temperature above 40°F (4°C)
 - GS-54 Installation temperature above -40°F (-40°C)
- (1) Required for LBTV2 (see step 1)

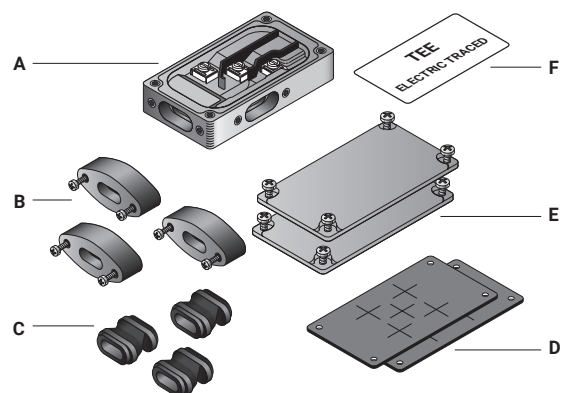

⚠ WARNING:

This component is an electrical device that must be installed correctly to ensure proper operation and to prevent shock or fire. Read these important warnings and carefully follow all of the installation instructions.

- To minimize the danger of fire from sustained electrical arcing if the heating cable is damaged or improperly installed, and to comply with the requirements of Chemelex, agency certifications, and National Electrical Codes, ground-fault equipment protection must be

used. Arcing may not be stopped by conventional circuit breakers.

- Component approvals and performance are based on the use of Chemelex-specified parts only. Do not use substitute parts or vinyl electrical tape.
- The black heating cable core is conductive and can short. It must be properly insulated and kept dry.
- Damaged bus wires can overheat or short.

Do not break bus wire strands when scoring the jacket or core.

- Keep components and heating cable ends dry before and during installation.
- Bus wires will short if they contact each other. Keep bus wires separated.
- Use only fire-resistant insulation materials, such as fiberglass wrap or flame-retardant foam.

1

- Identify heating cable type.
- Select correct grommet from table below.

| Heating Cable | Type | Grommet |
|---------------|------------|----------------------|
| BTV, QTVR | -CR or -CT | RED |
| LBTV2 | -CT | K (Order separately) |
| KHP | -CR | RED |

WARNING: Use of the wrong grommet can result in leaks, cracked components, shock or dielectric failure, and will invalidate approvals and certifications.

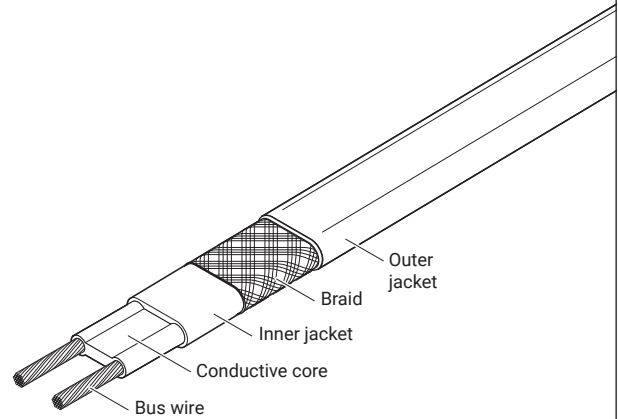

BTV-CR, BTV-CT, QTVR-CT, LBTV2-CT, KHP-CR

2

- Allow extra heating cable as shown.

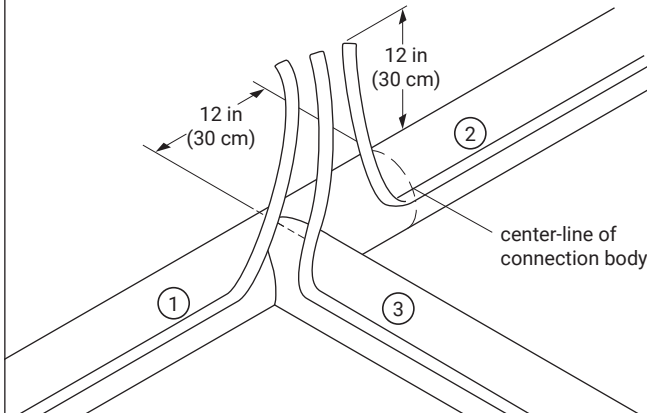

3

- Slide parts onto heating cable in order shown.

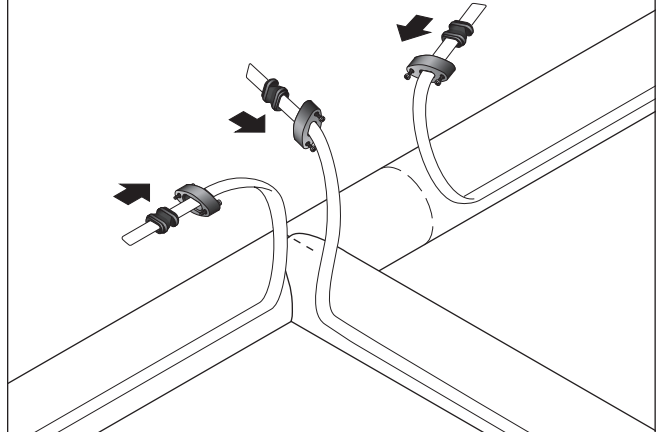

4

Do not cut braid.

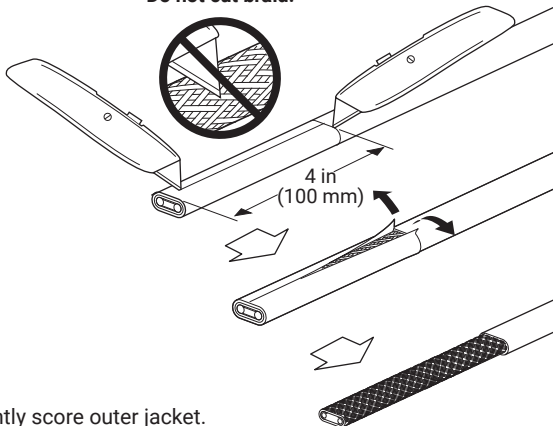

- Lightly score outer jacket.
- Bend heating cable to break jacket at score, then peel off jacket.

5

- Push braid back to create a pucker.
- At pucker use a screwdriver to open braid.
- Bend heating cable and work it through opening in braid.

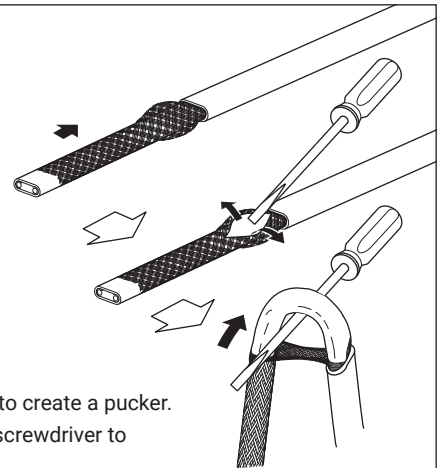

6

- Pull braid tightly to center of cable to make a pigtail.

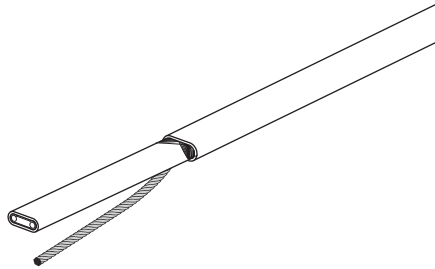

7

Do not cut bus wires

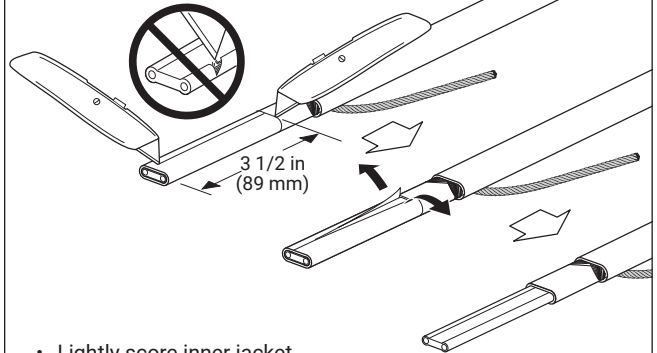

- Lightly score inner jacket.
- Peel off jacket.

8

- Notch core.
- Twist back and peel bus wire from core.

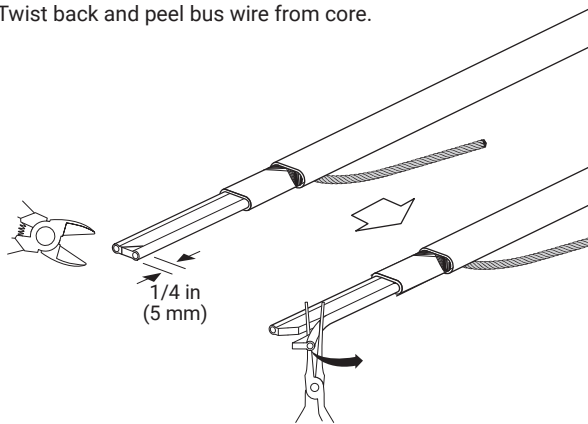

9

- Score core between bus wires and inner jacket.
- Bend and snap core.
- Peel core free from bus wire.
- Clean bus wires.

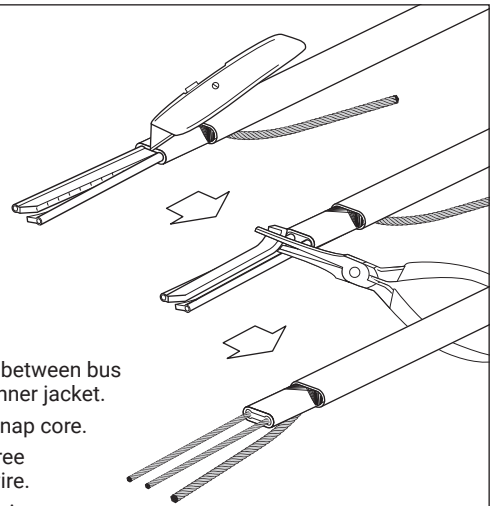

10

- Push heating cable number 3 into body. Slide grommet into cavity and seat.
- Tighten pressure plate screws to body.

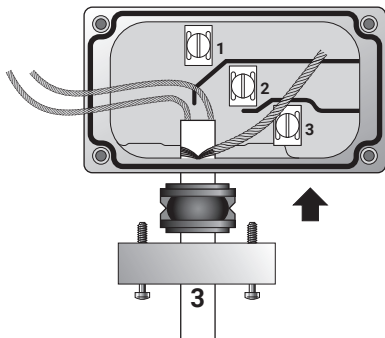

11

- Push braid wires away from bus wires.
- Remove screws, lockwashers and clamps.
- Position wires on blocks.
- Refit clamps, lockwashers, screws, and tighten.
- Trim all extra lengths of wire and remove any loose wires.

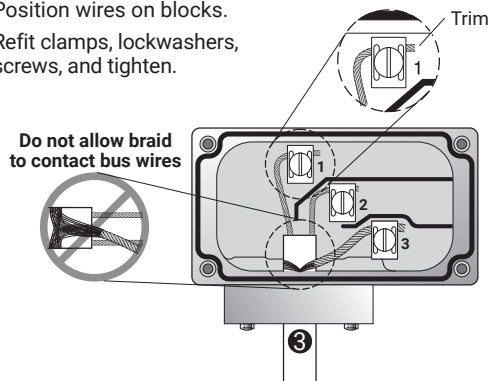

12

- Turn over tee body.
- Push heating cables 1 and 2 into body, slide grommets into cavities and seat.
- Tighten pressure plate screws to body.

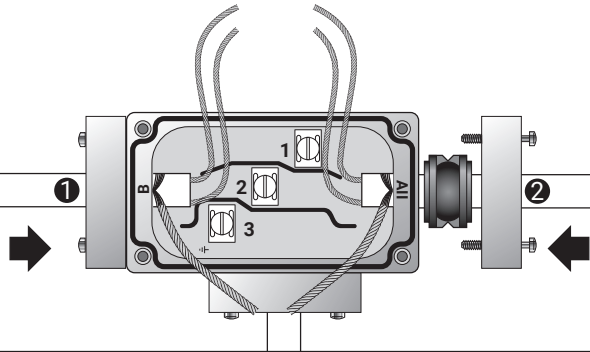

13

- Remove screws, lockwashers and clamps.
- Push braid wires away from bus wires.
- Position wires on blocks.
- Refit clamps, lockwashers, screws, and tighten.
- Trim all extra lengths of wire and remove any loose wires.

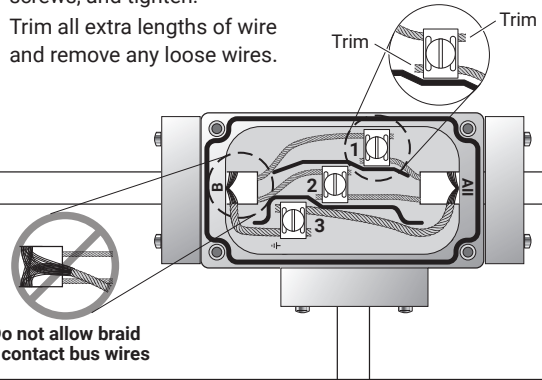

14

- Remove release lining, if present, from gasket.
- Position gaskets and covers on body.
- Tighten covers to body.

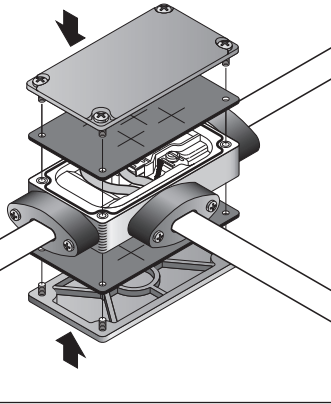

15

- Tape tee to pipe.
- Loop and tape extra heating cable to pipe.
- Install label on outside of cladding.

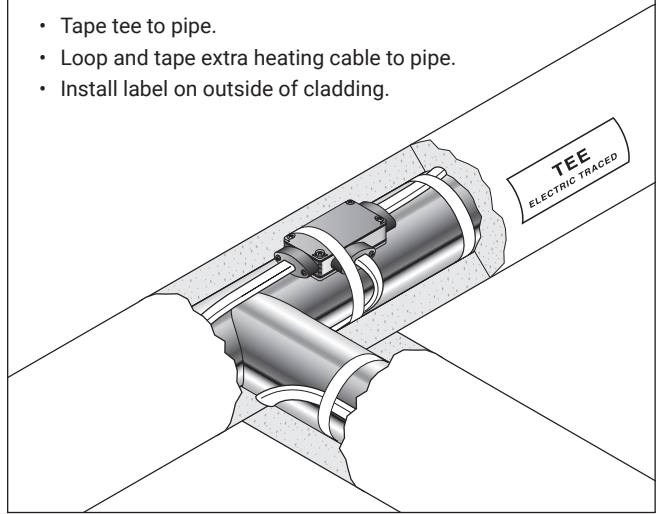

North America

Tel +1 800 545 6258
info@chemelex.com

Europe, Middle East, Africa, India

Tel +32 16 213 511
Fax +32 16 213 604
info@chemelex.com

Asia Pacific

Tel +86 21 2412 1688
infoAPAC@chemelex.com

Latin America

Tel +1 713 868 4800
info@chemelex.com

chemelex
excellence is everything

Raychem

Tracer

Pyrotenax

Nuheat