

# Raychem

## Industrial Heat Tracing

Installation and maintenance manual for mineral insulated cable systems applied to pipes and vessels

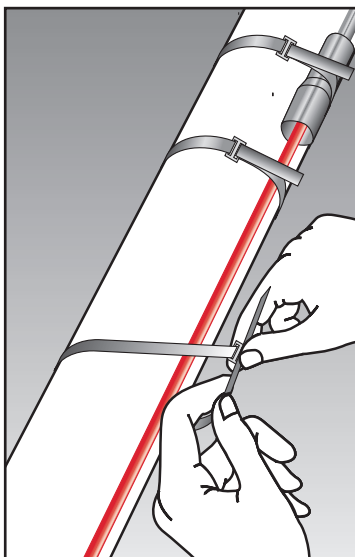

## Important Safeguards and Warnings

### **WARNING: FIRE AND SHOCK HAZARD.**

Raychem heat-tracing systems must be installed correctly to ensure proper operation and to prevent shock and fire. Read these important warnings and carefully follow all the installation instructions.

- To minimize the danger of fire from sustained electrical arcing if the heating cable is damaged or improperly installed, and to comply with Chemelex requirements, agency certifications, and national electrical codes, ground-fault equipment protection must be used on each heating cable branch circuit. Arcing may not be stopped by conventional circuit breakers.
- Approvals and performance of the heat-tracing systems are based on the use of approved components and accessories.
- Cable terminations must be kept dry before, during, and after installation.
- Damaged heating cable can cause electrical arcing or fire. Use only Raychem approved pipe straps or tie wire to secure the cable to the pipe.
- Damaged heating cable or terminations must be repaired or replaced. Contact factory for assistance.
- Use only fire resistant insulation which is compatible with the application and the maximum exposure temperature of the system to be traced.
- To prevent fire or explosion in hazardous locations, verify that the maximum sheath temperature of the heating cable is below the autoignition temperature of the gases in the area. For further information, see the design documentation.
- Heating cables are capable of reaching high temperatures during operation and can cause burns when touched. Avoid contact when cables are powered. Insulate the pipe before energizing the cable. Use only properly trained personnel.
- Material Safety Data Sheets (MSDSs) are available on our website: [Chemelex.com](http://Chemelex.com)

# Table of Contents

---

<b>1</b>	<b>General Information</b>	<b>1</b>
	1.1 Use of the Manual	1
	1.2 Safety Guidelines	2
	1.3 Typical System	2
	1.4 Electrical Codes	3
	1.5 Warranty and Approvals	3
	1.6 Heating Cable Construction	4
	1.7 Heating Cable Identification	6
	1.8 Heating Cable Temperature Information	7
	1.9 General Installation Guidelines	7
	1.10 Heating Cable Storage	9

---

<b>2</b>	<b>Pre-Installation Checks</b>	<b>10</b>
	2.1 Check Materials Received	10
	2.2 Check Piping to be Traced	10
	2.3 Check Tools	10

---

<b>3</b>	<b>Heating Cable Installation</b>	<b>11</b>
	3.1 Heating Cable Handling	11
	3.2 Heating Cable Installation on Pipes	16
	3.3 Temperature Sensor Installation for Pipes	23
	3.4 Heating Cable Installation on Tanks and Vessels	24
	3.5 Temperature Sensor Installation for Vessels	27

---

<b>4</b>	<b>Component Installation</b>	<b>28</b>
	4.1 General Component Information	28

---

<b>5</b>	<b>Control and Monitoring</b>	<b>30</b>
----------	-------------------------------	-----------

---

<b>6</b>	<b>Thermal Insulation and Marking</b>	<b>31</b>
	6.1 Pre-Insulation Checks	31
	6.2 Insulation Installation Hints	31
	6.3 Marking	32
	6.4 Post-Insulation Testing	32

---

<b>7</b>	<b>Power Supply and Electrical Protection</b>	<b>33</b>
	7.1 Voltage Rating	33
	7.2 Electrical Loading	33
	7.3 Temperature Controller Wiring	34

---

<b>8</b>	<b>Commissioning and Preventive Maintenance</b>	<b>35</b>
	8.1 Tests	35
	8.2 Preventive Maintenance	37

---

<b>9</b>	<b>Test Procedures</b>	<b>39</b>
	9.1 Visual Inspection	39
	9.2 Insulation Resistance Test – Test 1	39
	9.3 Continuity (Resistance) Test – Test 2	40
	9.4 Insulation Resistance and Continuity Test	41

---

<b>10</b>	<b>Troubleshooting Guide</b>	<b>44</b>
-----------	------------------------------	-----------

---

<b>11</b>	<b>Installation and Inspection Records</b>	<b>48</b>
	Heating Cable Installation Record	48
	Installation Record Required for Class I, Division 1, Hazardous Locations According to IEEE 515	50
	Heating Cable Commissioning Record	52
	Maintenance Log Record	54

# 1

## General Information

---

### 1.1 Use of the Manual

This installation and maintenance manual is for Raychem Mineral Insulated (MI) heat-tracing systems installed on thermally insulated metal pipes and vessels only. This includes Raychem XMI-A Alloy 825 sheathed, XMI-L low temperature sheath and copper sheathed pre-terminated, series-resistance MI heating cables and components.

This manual assumes that the heating cable designs have been completed using TraceCalc Pro software available from Chemelex or following the design steps in H56884, Mineral Insulated Heating Cables, found in the Industrial Heat-Tracing Product Selection and Design Guide. Chemelex offers complete integrated service from original design, to product specification, to installation of the complete system. We also provide future maintenance of the installation, if required.

For design assistance, technical support, or information regarding applications where the MI heating cable will be used for heat-tracing of plastic pipes, flexible or expansion joints, or in submerged environments, please contact your Chemelex representative or Chemelex directly.

#### **Chemelex**

7433 Harwin Drive  
Houston, TX 77036  
USA

Tel: +1 800 545 6258

info@chemelex.com

**chemelex.com**



**Important: For the Chemelex warranty and agency approvals to apply, the instructions that are included in this manual and with associated products must be followed.**

# 1

## General Information

### 1.2 Safety Guidelines

The safety and reliability of any heat-tracing system depends on the quality of the products selected, and on proper design, installation, and maintenance. Incorrect design, handling, installation, or maintenance of any of the system components can cause underheating or overheating of the pipe, or damage to the heating cable system, and may result in system failure, electric shock, or fire. The guidelines and instructions contained in this guide are important. Follow them carefully to minimize these risks and to ensure that the MI system performs reliably.

### 1.3 Typical System

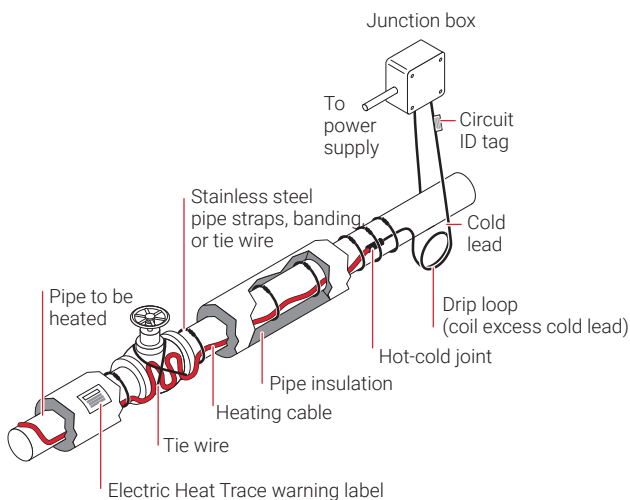

**Figure 1: Typical Design B system**

# 1

## General Information

---

### 1.4 Electrical Codes

Articles 427 and 500 of the National Electrical Code and Sections 18 and 62 of the Canadian Electrical Code, Part 1, in particular, govern the installation of electrical heat-tracing systems in hazardous and nonhazardous locations. Installation of heat-tracing systems must comply with all national and local codes. In particular, ground-fault equipment protection is required for all electric heat-tracing installations to prevent arcing, fire, and shock if the cable is improperly installed or damaged.

### 1.5 Warranty and Approvals

Raychem XMI-A Alloy 825 sheath and copper sheath MI heating cables are approved for use in nonhazardous locations and Class I, Division 1 & 2 Groups A, B, C, D, Class II, Division 1 & 2, Groups E, F, G, Class III hazardous locations. Class I Zone 1 AEx eb IIC T\* Gb – for US and Ex 60079-30-1 IIC T\* Gb – for Canada.

Raychem XMI-L low temperature sheath heating cables are approved for use in Class I, Division 2 Groups A, B, C, D, Class II, Division 2, Groups E, F, G Class III hazardous locations and Class I Zone 2 AEx nA IIC T\* Gc – for US and Ex 60079-30-1 IIC T\* Gc – for Canada. Refer to specific product data sheets for details.



**Note: T\*- refer to design documentation**



Chemelex' limited standard warranty applies to all products. You can access the complete warranty on [chemelex.com](http://chemelex.com). To qualify for an extended 10-year warranty, register online within 30 days of installation at [chemelex.com](http://chemelex.com)

# 1

## General Information

### 1.6 Heating Cable Construction

The heating cables are available as factory-terminated units in the configurations shown in Table 1.

**TABLE 1: MI HEATING CABLE CONFIGURATION**

MI cable design	Number of conductors	Configuration
<b>XMI-A Heating Cables</b>		
A	Single conductor (XMI-A61 series)	<p>Heated length Cold lead length</p>
B	Single conductor (XMI-A61 series)	<p>Cold lead length Heated length Cold lead length</p>
D	Dual conductor (XMI-A32 and XMI-A62 series)	<p>Heated length Cold lead length</p>
E	Dual conductor (XMI-A32 and XMI-A62 series)	<p>Cold lead length Heated length Cold lead length</p>
<b>XMI-L Heating Cables</b>		
D	Dual conductor (XMI-L32 and XMI-L62 series)	<p>Heated length Cold lead length</p>
E	Dual conductor (XMI-L32 and XMI-L62 series)	<p>Cold lead length Heated length Cold lead length</p>

# 1

## General Information

A sectional view of a Design D XMI-A Alloy 825 sheath MI heating cable is shown in Figure 2. All of the cables include both a heating section and a non-heating cold lead section. These sections are joined in the hot-cold joint where the heating element is spliced into larger bus wires. A final transition at the end of the cold lead section provides an environmental seal and tails for the electrical connection. At the opposite end of the cable, the conductors of Design D cables are joined and hermetically sealed within an end cap. XMI-L low temperature sheath cables have an additional corrugated sheath over the heated section as shown in Figures 3 and 4.

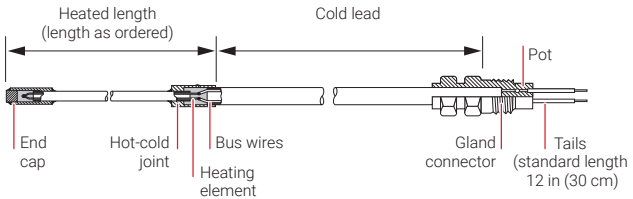

**Figure 2: Sectional view of Design D XMI-A MI cable**

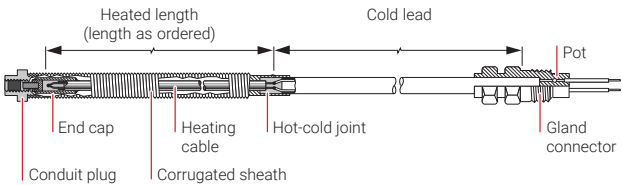

**Figure 3: Sectional view of Design D XMI-L MI cable**

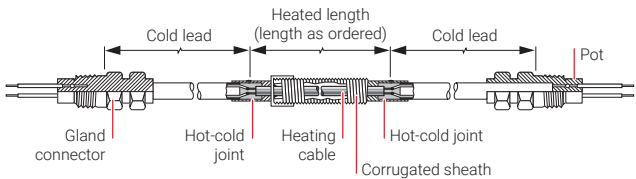

**Figure 4: Sectional view of Design E XMI-L MI cable**

# 1

## General Information

### 1.7 Heating Cable Identification

Each MI heating cable is supplied with an identification tag on which the heating cable catalog number is permanently printed. In addition to its identification purposes, the catalog number provides information regarding the heating cable length, power output, and operating voltage. Also printed on the tag are the designer's circuit identification number, serial number and the maximum temperature the cable sheath may attain along with other design information.

If the cable has been designed for a hazardous location, the area classification is printed in the 'Haz. Locations' section of the tag.



Figure 5: Typical MI identification tag (front)

The heating cable catalog number may be broken out as follows:

**D/32SA2200/35/200/120/7/LS23A/X/N12**

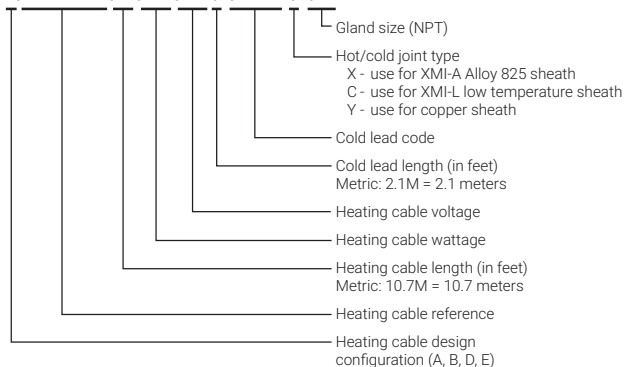

Figure 6: MI heating cable catalog number

# 1

## General Information

**⚠ WARNING: Fire or explosion hazard. Ensure that the information provided in the Haz. Locations and Temp. Code [Max. Sheath Temp.] fields comply with the area in which the heating cable will be installed.**

### 1.8 Heating Cable Temperature Information

MI heating cables are available for a variety of applications, with several sheath materials to suit different temperature requirements. The maximum maintain and exposure temperatures for these sheath materials is shown in Table 2.

**TABLE 2: MAXIMUM CABLE TEMPERATURE**

Product family	Maximum maintain temperature	Maximum continuous exposure temperature	Maximum continuous exposure temperature for hot/cold joints and end cap
XMI-A	1022°F (550°C)	1200°F (650°C)	1022°F (550°C)
XMI-L (Note 1)	752°F (400°C)	1022°F (550°C)	1022°F (550°C)
Copper	300°F (150°C)	392°F (200°C)	300°F (150°C)
LSZH jacketed copper	158°F (70°C)	194°F (90°C)	194°F (90°C)

Note 1: 842°F/450°C if corrosives are present

### 1.9 General Installation Guidelines

These guidelines are provided to assist the installer throughout the installation process and should be reviewed before the installation begins.

Avoid damage to the MI heating cable as follows:

- Do not repeatedly bend and straighten the cable.
- Do not bend within 6 inches (15 cm) of a splice, the hot-cold joint, or the end cap.
- Do not bend the cold lead within 6 in (15 cm) of the termination pot seal.
- Do not alter cable length.
- Do not energize before installation is complete.
- Do not use screw type adjustable pipe straps/banding.
- Avoid crushing and excessive bending or pulling of cold leads during installation, testing and commissioning

# 1

## General Information

---

- Do not install so that cables are crossed, overlapped, or grouped. Grouped cables can cause localized overheating with a risk of fire or cable failure.
- Keep welding torches well clear of cable and protect against slag falling on cables below.



**Important: When welding, the ground clamp must be kept as close to the welding area as possible.**

- Ensure all pipes, tanks, etc., have been released by the client for tracing prior to heating cable installation.
- Heating cables must be spaced at least 1/2 in (13 mm) from any combustible surface.
- The metal sheath of XMI-A and XMI-L heating cables shall be bonded to the circuit bonding conductor, but shall not be used as the bonding means. Metallic structures or materials used for the support of, or on which the heating cables are installed, must be bonded to ground in accordance with CSA Standard C22.1, Section 10, or the National Electrical Code as applicable.
- In case of multiple tracing or spiraling, space cable(s) at least 1 inch (2.5 cm) apart, if possible (Figure 17).
- Install cable in a manner that permits removal of serviceable equipment such as valves, pumps, filters, and so on, with minimum disruption to the surrounding heating cable.
- Use stainless steel pipe straps, stainless steel banding, or 16 AWG or larger stainless steel tie wire to fasten XMI-A and XMI-L heating cables to pipes. Use stainless steel pipe straps, stainless steel banding, or 16 AWG or larger copper tie wire to fasten copper sheathed heating cables to pipes.
- Avoid bending cable to an inside radius less than 6 times the outside diameter of the cable, when installing on valves, pumps, and other irregularly shaped surfaces. On small flanges and joints where it is impractical to bend the cables tightly, metal foil or metal bridging pieces can be used to fill gaps between the heating cable and the surface to be heated.

# 1

## General Information

---

- Ensure heating cable sheath material is suitable for the maintain and continuous exposure temperatures shown in Table 2. If the anticipated maximum continuous exposure temperature of the hot-cold joint or end cap of the cable to be installed exceeds the values in Table 2, install as shown in Figure 26.
- Apply thermal insulation as soon as possible after heat-tracing to prevent mechanical damage to the heating cables. Waterproof cladding must be installed immediately after insulation is applied to prevent the insulation from becoming wet.
- Make all connections to supply cables in above grade junction boxes and keep covers on junction boxes when not working on them.
- To maintain the integrity of the epoxy seal termination, avoid the application of excessive heat to the epoxy during installation, commissioning and operation of the heating units
- The minimum installation temperature is  $-76^{\circ}\text{F}$  ( $-60^{\circ}\text{C}$ ).
- Use a temperature controller suitable for the process temperature. Chemelex supplies a wide range of temperature controllers including the Raychem series electronic monitoring controllers.



**Important: DO NOT remove metal tags from cold lead.**



**Important: Repair or assembly of field-fabricated units shall be done by a person qualified to do so and in accordance with the Chemelex requirements.**

### 1.10 Heating Cable Storage

- Store heating cables in a clean dry location and protect them from mechanical damage.
- Temperature range  $-40^{\circ}\text{F}$  to  $140^{\circ}\text{F}$  ( $-40^{\circ}\text{C}$  to  $60^{\circ}\text{C}$ )
- Store heating cables in their shipping container until they are installed.

# 2

## Pre-Installation Checks

---

### 2.1 Check Materials Received

Review the heating cable design drawings/schedules and compare the list of materials to the catalog numbers of heating cables and components received to confirm that proper materials are on site. If in doubt, measure the conductor resistance and check against that of the schedule. The heating cable voltage, wattage, and length are printed on the metal tag attached to the cold lead.

- Ensure that the heating cable voltage rating is suitable for the source voltage available.
- Inspect the heating cable and components for in-transit damage.
- Perform continuity and insulation resistance testing (minimum 100 MΩ) on each cable as detailed in Section 9 and record the results on the Heating Cable Installation Record in Section 11.

### 2.2 Check Piping to be Traced

- Make sure all mechanical pipe testing (i.e. hydrostatic testing/purging) is complete and the system has been cleared by the client for tracing.
- Walk the system and plan the routing of the heating cable on the pipe.
- Verify that the actual pipe length, routes, and location of pipe fittings such as valves, pipe supports, hangers, and other components match the design drawings.
- Inspect the piping for burrs, rough surfaces or sharp edges that may damage the heating cable. Remove if necessary.
- Verify that any surface coatings are dry to the touch.

### 2.3 Check Tools

The following tools are recommended for installing MI heat-tracing systems:

- Lineman's pliers
- Screwdriver
- Adjustable wrench
- Deadblow mallet

# 3

## Heating Cable Installation

### 3.1 Heating Cable Handling

- Handle heating cable with care. Take care when bending the cable around pumps, valves, and flanges.
- Protect cold lead tails from damage by threading a short section of PVC pipe on to the gland connector as shown.

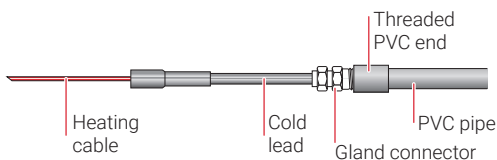

**Figure 7: Protecting cold lead tails**

- Avoid damaging heating cables by cutting or crushing.
- Uncoil heating cables along a floor or surface to avoid kinking or twisting. DO NOT pull out into a spiral.
- Handle the hot-cold joint carefully. Support the joint on both sides when moving and positioning the cold lead.
- Do not bend the cold lead using a length of pipe, placed over the tails and pot, as a fulcrum to facilitate the bend. The cold lead and/or pot will be damaged. Bend the cold lead using a bending tool designed to bend cable or conduit.
- Keep cables clean and dry.
- To prevent galling of threads when using stainless glands, a thread lubricant should be applied to the male thread mating with the female backnut.

### Heating cable allowances

All parts of a heat traced system which increase the surface area of the normally insulated pipe/ vessel (e.g. valves or flanges) or metallic fins that protrude out of the insulation (e.g. supports), will increase the overall heat loss. These areas of increased heat loss require compensation, either by using higher overall design safety factors or by the addition of extra cable length. The heating cable allowances are specified in design software and documentation.

# 3

## Heating Cable Installation

---

In such cases sufficient cable should be added in such a way to at least enable removal of instruments, valves etc (“maintenance loop”). For pipes requiring more than one run of heating cable, apply the full allowance for each run of cable on each fitting or support as long as space allows. However, MI heating cables must not touch or overlap and the minimum spacing between the heating cables must be observed. The minimum spacing between cables is 1” (2.5cm). Contact Chemelex if more than two runs are needed or if cable spacing is less than 1” (2.5 cm). For some applications, it may be physically impossible to install all of the recommended allowance directly on the fitting or support. In this case, install the excess heating cable on the pipe on either side of the fitting or support, or distribute the additional heater length along the entire circuit length if a lower local temperature is acceptable.

This constraint may be difficult for small pipes and/or multiple cable runs. If required, contact Chemelex for assistance.

For further details on individual allowances please refer to the design documentation or the Chemelex design software (e.g. TraceCalc Pro reports).

For NPS sizes 2" and smaller (in outdoor applications where wind may be significant) it is recommended that all components are fully insulated as there is a risk of a lower maintain temperature on the components due to heat losses.

# 3

## Heating Cable Installation

### Positioning heating cables

Install cables around the bottom section of pipe, avoiding bottom dead center (Figure 8).

For two cable runs, install between 30° and 45° on either side of bottom dead center (Figure 8).

For three cable runs (as in a three phase installation) install bottom cable about 10° to one side of bottom dead center (Figure 8). On a vertical pipe, space cables evenly around circumference of pipe.

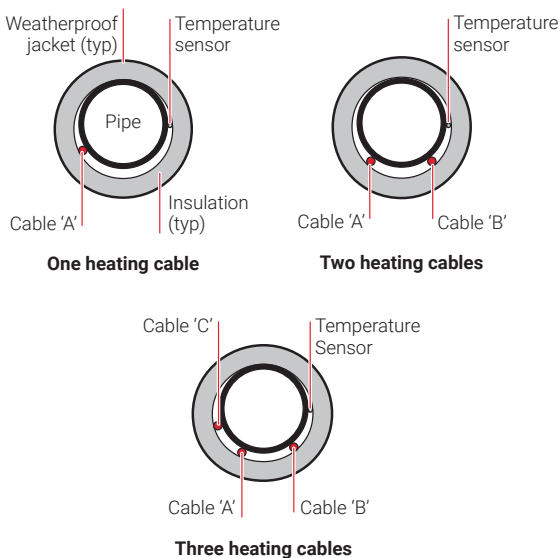

**Figure 8: Cable positioning—typical cross section**

Care must be taken at joints, flanges, valves or any obstructions on the pipe line to prevent damage to the heating cables during installation.

# 3

## Heating Cable Installation

### Attaching cold leads

Attach the hot/cold joint to the pipe or vessel ensuring that it is firmly anchored to the heated surface and check that the hot/cold joint is not damaged during installation.



**Important:** In some instances it is not permitted to have a hot-cold joint or end cap anchored to the heated surface because of the risk of exceeding the maximum recommended exposure temperature (see Table 2). In such instances, follow the installation detail shown in Figure 26.

Cold leads should always emerge from the thermal insulation in such a way that the resultant hole in the insulation cannot admit water or other contaminants. Coil excess length of cold lead as it exits the insulation (Figure 16) and ensure that cold leads can accommodate any movement of the pipe work.

### Bending the cable

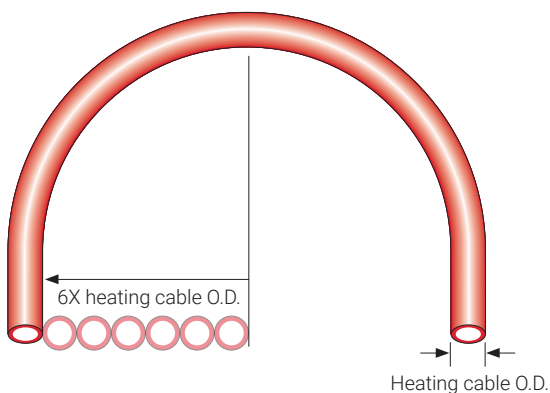

Figure 9: Minimum bend radius

# 3

## Heating Cable Installation

When positioning the heating cable on the pipe, do not bend to an inside radius less than 6 times the outside diameter of the heating cable. For XMI-L cables, note that the heating cable is contained within the corrugated outer sheath, and the heating cable outside diameter should be used for calculation of the minimum bending radius rather than the outside diameter of the corrugated sheath. Refer to the XMI-L heating cable data sheet, H59079, for information on heating cable bending radius.

### Crossing the cable

Do not cross, overlap, or group the heating cables.

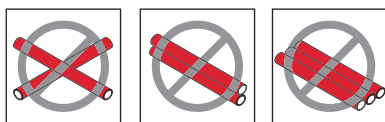

Figure 10: Crossing, overlapping, and grouping

### 3.2

#### Heating Cable Installation on Pipes

Chemelex recommends that you complete the Heating Cable Installation Record during the installation of the heating cable and thermal insulation and keep this record for future reference.



**Important: The FM Required Installation Record for Class I, Division 1, Hazardous Locations (Section 11) must be completed and submitted to Chemelex to complete the FM approval process.**

- If mounting junction boxes or other ancillary equipment onto pipe via brackets, install brackets on pipe before installing heating cables. This will avoid damage to the heating cable, as the tension required to secure the banding for the bracket is greater than the tension required to secure the cable banding.

# 3

## Heating Cable Installation

- **Where feasible, uncoil the single heating cable and lay it alongside the pipe section to be traced.** For shorter Design B single conductor cable which is to be installed in the form of a “hairpin,” it may be advantageous to unroll the heating cable, loop it, and then lay it alongside the pipe section so that both runs of cable can be installed simultaneously.

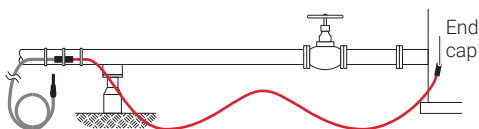

**Figure 11: Uncoiling heating cable**

- Attach hot-cold joint to end of pipe nearest the power supply point, and other end of heating cable to the other end of the pipe. Support hot-cold joint by attaching cable with pipe straps/banding at a distance of 6 inches (15 cm) on either side of joint. Secure joint itself to pipe with a pipe strap/ band as shown in Figure 16.
- Fasten middle of heating cable to the halfway point of pipe leaving equal slack on either side.

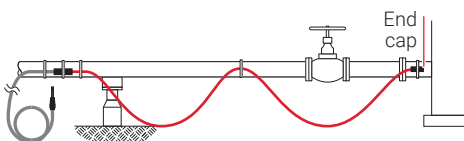
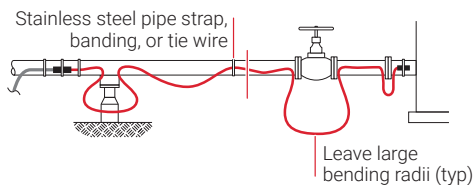

**Figure 12: Attaching hot-cold joint and end cap**

- Attach heating cables to pipe with pipe straps/ banding, or tie wire, at intervals of 18 inches (45 cm) or less. Tie wire should be snug, but should not cut or indent the sheath. **When installing copper sheathed heating cables using tie wire, use only 16 AWG or larger copper tie wire to prevent cutting into the cable sheath.**
- Allow extra cable per design specifications and drawings at all pipe fixtures.

# 3

## Heating Cable Installation



**Figure 13: Allowances for valves, flanges, and pipe supports**

- Use tie wire to hold cable to irregularly shaped components such as valves or pipe supports.
- In hazardous locations, when attaching heating cable to irregular shaped components such as flanges and valves, use pipe straps on either side of the component to secure the cable to the pipe.

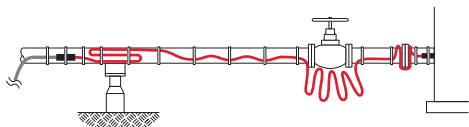

**Figure 14: Installing cable on valves and pipe supports**

- Allow cable to wave along pipe as per Figure 16 and Figure 17. This allows for expansion and contraction of the heating cable as it heats up and cools down. Use up excess cable by waving along pipe and increasing amount used at each pipe support.



**Important: Do not use up excess cable at one location. Distribute equally along pipe.**

# 3

## Heating Cable Installation

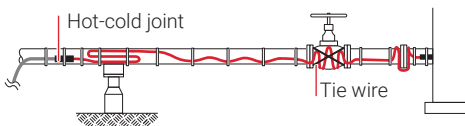





Figure 15: Completed MI heating cable installation

 **Important:** For hazardous area installations any reappportioning of cable should be verified by those responsible for the system design.

 **Important:** If tensioning tools are used, avoid over-tightening pipe straps, banding, or tie wire used to attach heating cable as this can damage the heating cable. This permits movement of heating cable during its heating cycle, as restricted movement can lead to cable failure due to fatigue.

 **WARNING:** Fire and shock hazard. Do not install damaged cable. Heating cable must be repaired or replaced before installation.

### Typical pipe installation details

The following illustrations show general installation methods. Actual installation configurations will vary depending on the number of heating cables being installed and the shape of the components being traced.

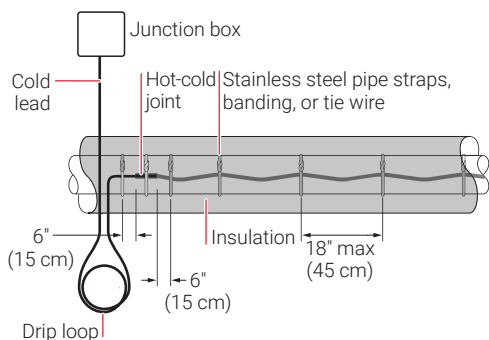
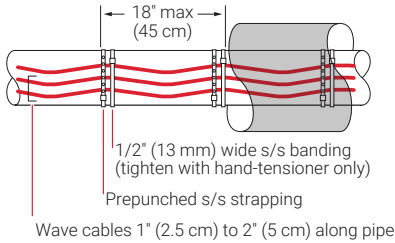

Figure 16: Pipe strap spacing

# 3

## Heating Cable Installation



**Note:** Where several runs of cable are required on one pipe, prepunched strapping may aid in the installation and spacing of cables.

**Figure 17: Fastening several runs of cable**

For valve sizes 3-1/2" (9 cm) or smaller

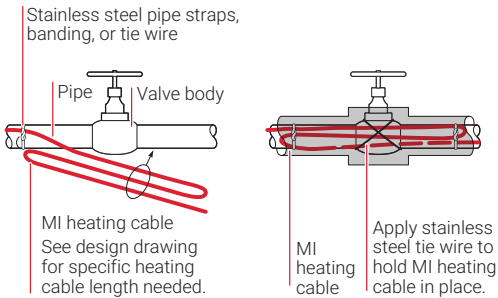

For valve sizes larger than 3-1/2" (9 cm)

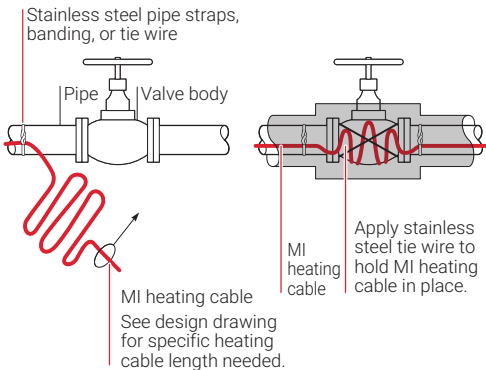

**Figure 18: Valves**

# 3

## Heating Cable Installation

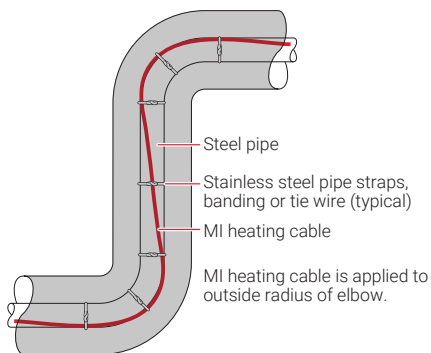

**Figure 19: Installation at 90° elbow**

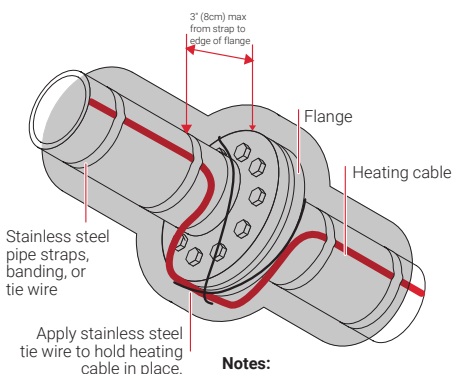

**Notes:**

1. Heating cable must maintain contact with flange when bending the cable around the pipe flanges.
2. In hazardous areas, secure the cable to the pipe on either side of the flange using pipe straps.

**Figure 20: Flanges**

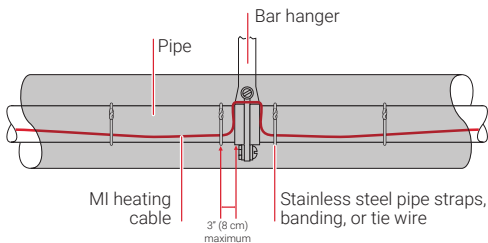

**Notes:** In hazardous areas, secure the cable to the pipe on either side of the pipe support using pipe straps

**Figure 21: Hanger type pipe support**

# 3

## Heating Cable Installation

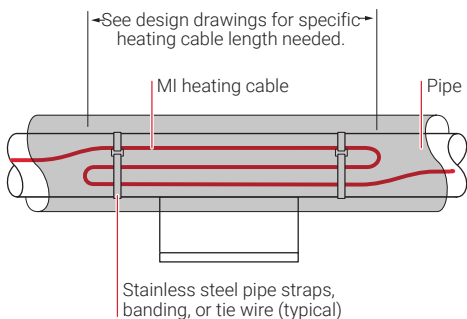

**Note:** Minimum 1" (2.5 cm) spacing, if possible.

**Figure 22: Shoe and sleeve type support**

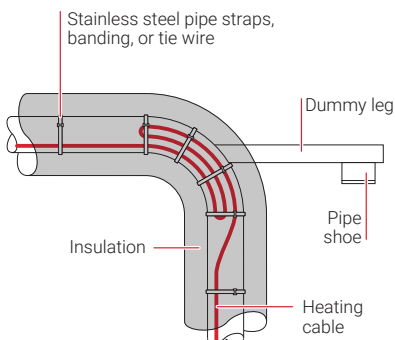

**Notes:**

1. Minimum 1" (2.5 cm) spacing.
2. Check drawings for dummy leg insulation.

**Figure 23: Dummy supports**

# 3

## Heating Cable Installation

Pumps should have their own heating cable, separate from the connecting pipe.

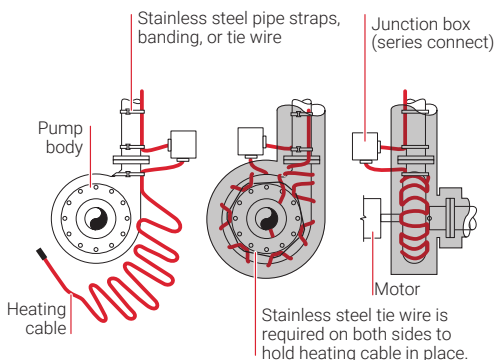

### Notes:

1. Minimum 1" (2.5 cm) spacing, if possible.
2. Cover heating cable with metal foil or equal before applying insulation to ensure the cable does not become trapped in the insulation.

**Figure 24: Pumps**

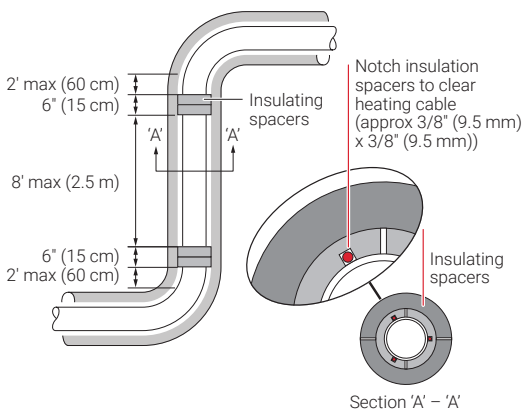

### Notes:

1. When using oversize insulation to allow space for heat tracing, use insulating spacers at intervals not exceeding 8 ft (2.5 m) to reduce chimney effect between the pipe and insulation.
2. Insulating spacers to be same material as oversize insulation.

**Figure 25: Risers**

# 3

## Heating Cable Installation

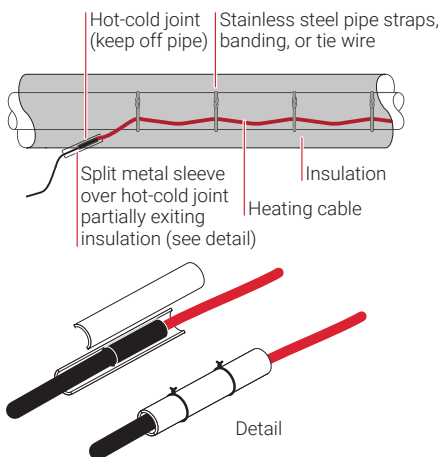

**Figure 26: When maximum pipe temperature exceeds cold lead or hot-cold joint and end cap capability**

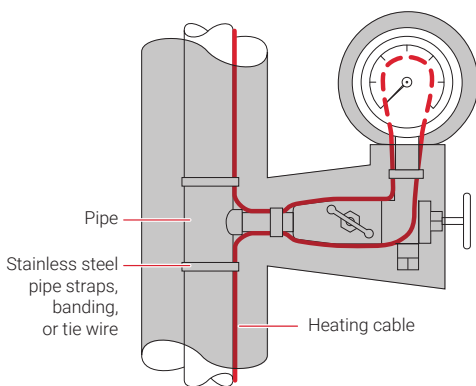

**Figure 27: Pressure gauge**

### 3.3 Temperature Sensor Installation for Pipes

Secure the temperature sensor to the pipe using pipe straps or banding. Position the sensor element parallel to the pipe and in a location where it will not be affected by the heating cable (Figure 28). In all cases it is essential that the temperature sensor

# 3

## Heating Cable Installation

be positioned in accordance with the designer's instructions.



**Important:** The temperature sensor must be installed so that it senses the temperature conditions within the heating zone. For example, where flow and static conditions occur within one heating zone, the temperature sensor should be located at a point of no flow and away from the end of the pipe or a component such as a pipe support.

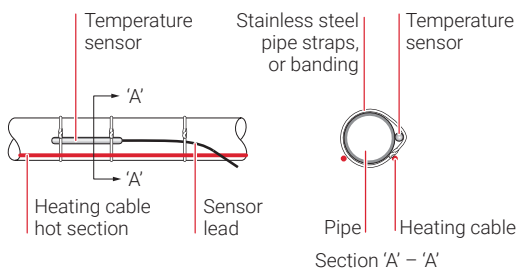

**Figure 28: Pipe-mounted temperature sensor**

The temperature sensor should be strapped in good thermal contact with the pipe and protected so that insulating materials cannot become trapped between it and the heated surface. Install temperature sensor with care as damage may cause a calibration error.

### 3.4 Heating Cable Installation on Tanks and Vessels

On vessels, tanks, or large surfaces, the heating cable is worked onto the area to form a heating mat. Prepunched strapping, where allowable, may be spot welded to the surface of the vessel to be heated and the heating cable attached to it. When using prepunched strapping, bend the tabs on the prepunched strapping backwards over the cable as shown in Figure 29. Note that prepunched strapping will not accommodate XMI-L cables due to the larger diameter of the outer corrugated sheath. In this case, wire mesh and tie wire may be used.

For irregular shaped vessels, or when installing

# 3

## Heating Cable Installation

---

XMI-L heating cables, the surface can be covered with a wire mesh and the heating cable fastened to the wire mesh using tie wire. Alternatively, the heating cable may be fastened to the wire mesh and the mesh applied to the vessel.

Consult design schedule for limits, proportions and spacing when marking out the surface area and ensure that the prepunched strapping or wire mesh is suitably located. This can be best achieved by marking out the cable run for spacing and extremities of the cable loops (Figure 29).

Use the following formula to determine cable spacing:

$$\text{Cable spacing (in)} = \frac{\text{Area to be heated (ft}^2\text{)} \times 12}{\text{Length of heating cables (ft)}}$$

Or if metric:

$$\text{Cable spacing (mm)} = \frac{\text{Area to be heated (m}^2\text{)} \times 1000}{\text{Length of heating cables (m)}}$$

Locate termination end of heating cable and attach to vessel, usually near electrical supply point. Trace over space marking and secure to vessel using previously attached prepunched strapping (Figure 29). Pay attention to minimum bending radius and heating cable spacing when forming loops.

# 3

## Heating Cable Installation

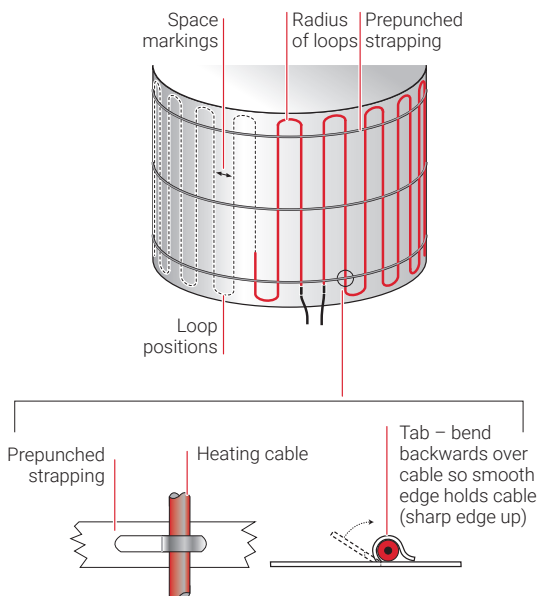
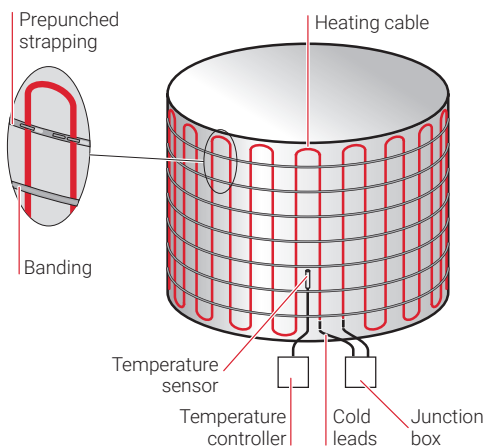

**Figure 29: Cable layout using prepunched strapping**

Install stainless steel banding over heating cable and strapping as shown in Figure 30. This prevents cable runs from becoming loose if they slip out from the “clip” on the strapping.

# 3

## Heating Cable Installation



### Notes:

1. Prepunched strapping can be cut to desired circumference and spot welded to tank to suit. Bands to be equally spaced on small vessels.
2. The heating cable can be fastened to wire mesh and then applied to the bottom and sides of the vessel.

**Figure 30: Typical vessel/tank installation**



**Important: Heating cable should be installed longitudinally on the vessel. Never spiral wrap the MI heating cable around the circumference of the vessel.**



**Important: Cover cable with metal foil if foamed-in-place insulation is used. This will prevent the cable from becoming trapped in the insulation.**

### 3.5

#### Temperature Sensor Installation for Vessels

Secure the temperature sensor to the vessel using pipe straps or banding, or where the temperature permits it, metal foil tape. Position the temperature sensor on the vessel between two runs of cable (Figure 30).

# 4

## Component Installation

---

### 4.1 General Component Information

Raychem heating cables must be terminated in a junction box suitable for the area classification.

Select appropriate components from Chemelex literature number H56884, Mineral Insulated Heating Cables, found in the Industrial Heat-Tracing Product Selection and Design Guide, or by using TraceCalc Pro software.

#### Component installation tips

- Ensure that the heating cable cold lead angles downward as it exits the insulation to prevent water ingress (Figure 16).
- Plan the location of the power connection junction box so that the excess cold lead can be coiled before entering the box, then mount the box firmly to a beam, stanchion, or pipe using appropriate mounting brackets. For series connected heating cables, junction boxes may be installed in a similar manner.
- Cable or conduit leading to junction boxes, temperature controllers, and transformers must be installed so that water does not enter the enclosure.
- Side entries are preferred to avoid condensation in bottom of junction box.
- Do not bend the cold lead within 6 in (15 cm) of the termination pot seal.
- Perform visual inspection of glands for scratches or damage, including threads
- Ensure surface of cable where gland will seal to sheath is clean
- If gland is contaminated: disassemble, clean, and visually inspect contaminated parts
- In CID1 hazardous locations glands must have a minimum of 5 threads engaged.

# 4

## Component Installation

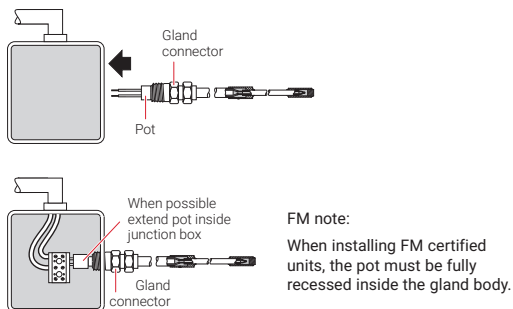

**Figure 31: Junction box connection**

- If necessary, remove the hole plug where the cold lead will enter the junction box. Screw a reducer into the junction box conduit hub if required, then insert the tails and screw the gland connector tight. Tighten the compression nut.



**Important: Make sure that the tails do not become trapped between the pot and gland connector or reducer bushing, if used.**



**Important: The compression nut must be tightened to the torque setting indicated on the tag attached to the gland connector. This ensures that the cable sheath is properly grounded and prevents moisture from entering the junction box.**

- Perform visual inspection of gland after tightening back nut and check for cracks, deformation / out-of-round.
- The torque tag on glands should not be removed (ensuring information available for future maintenance)
- Connect the cold lead tails and distribution power wires to the terminal block.
- Position the terminal block and wiring in the junction box and install the box lid. **Make sure lid is watertight.** Check to make sure that hole plugs are firmly tightened into any unused conduit hubs.

# 5

## Control and Monitoring

Raychem control and monitoring products are designed for use with Mineral Insulated heat-tracing systems. Thermostats, controllers and control and monitoring systems are available. Compare features of these products in the table below. For additional information on each product, refer to the Industrial Product Selection and Design Guide or contact your Chemelex representative.

Refer to the installation instructions supplied with control and monitoring products. Control and Monitoring systems should be installed by a certified electrician.

**TABLE 3: RAYCHEM CONTROL AND MONITORING PRODUCTS**

		Thermostats		Controllers			
		Multiple Options (visit <a href="http://www.chemelex.com">www.chemelex.com</a> )		Raychem Series			
			Elexant 4010i/ 4020i	920	NGC-30	NGC-40	
<b>Control</b>							
Ambient sensing			•	•	•	•	
Line-sensing	■		•	•	•	•	
PASC			•	•	•	•	
<b>Monitoring</b>							
Ambient temperature			•	•	•	•	
Pipe temperature			•	•	•	•	
Ground fault			•	•	•	•	
Current			•	•	•	•	
<b>Location</b>							
Local	■		•	•	•	•	
Remote			•	•	•	•	
Hazardous	E507S & ETS-05 only		•	•	•	•	
<b>Communications</b>							
Local display			•	•	•	○	
Remote display			•	•	○	○	
Network to DCS			•	•	•	•	

○ Indicates an optional component

# 6

## Thermal Insulation and Marking

---

### 6.1 Pre-Insulation Checks

Visually inspect the heating cable and components for possible damage or incorrect installation. Damaged cable must be repaired or replaced.

Perform continuity and insulation resistance tests on each cable following the procedure in Section 9. Confirm the results meet the minimum requirement stated in Test 1 and Test 2 and record them on the Heating Cable Installation Record in Section 11.

### 6.2 Insulation Installation Hints

- Make sure all of the piping is insulated according to the design specification, including valves, flanges, pipe supports, and pumps.
- Ensure thermal insulation is suitable for the temperatures involved and for the location of the pipe (i.e. outdoors or below grade).



**Important: Some types of insulation may be damaged by the high operating temperature reached by some MI cables.**

- Ensure that heating cable does not become trapped in the joint between the two half shells of insulation. In some cases, it may be necessary to cover the heating cable with metal foil to avoid this problem.
- Insulation must be properly installed and kept dry.
- Check insulation type and thickness against the design specification.
- To minimize potential heating cable damage, insulate as soon as possible after tracing.
- Check that pipe fittings, wall penetrations, and other irregular areas, have been completely insulated.
- When installing waterproof cladding, be sure drills, screws and sharp edges do not damage the heating cable. The cladding must be installed immediately after insulation is applied to prevent the insulation from becoming wet.

# 6

## Thermal Insulation and Marking

- To weatherproof the insulation, seal around all fixtures that extend through the cladding. Check around valve stems, support brackets, and thermostat capillaries and sensor leads.
- To minimize “chimney effect” on vertical lengths of piping when using oversized insulation, install baffles between the thermal insulation and the pipe at maximum 8-foot (2.5 m) intervals (Figure 25).
- To prevent localized overheating, do not allow thermal insulation or other material to become lodged between the cable and the pipe. If urethane foam insulation is applied over heating cable, special care must be taken to ensure that the urethane does not get between the MI heating cable and the pipe. This can be accomplished by banding the cable to the pipe, and applying a strip of metal foil longitudinally to the pipe over the cable.

 **WARNING: Use only fire-resistant insulation such as fiberglass, mineral wool or calcium silicate.**

### 6.3 Marking

Install “Electrically Traced,” or similar, warning labels along piping at 10-foot (3 m) intervals on alternate sides, and on equipment requiring periodic maintenance, such as valves, pumps, filters, and so on, to indicate presence of electric heating cables.

### 6.4 Post-Insulation Testing

After the insulation is complete, perform a continuity and insulation resistance test on each circuit to confirm that the cable has not been damaged (refer to Section 9).

# 7

## Power Supply and Electrical Protection

### 7.1 Voltage Rating

Verify that the source voltage corresponds to the heating cable voltage rating printed on the cable tag. For circuits where the heating cables are series connected, the sum of the voltages shown on the cable tags should equal the source voltage.

### 7.2 Electrical Loading

Size the over-current protective devices according to the design specification. If devices other than those identified are used, refer to the current rating (amps) on the heating cable tag to determine the electrical load.

#### Ground-fault protection

Use circuit breakers with 30-mA ground-fault protection on all heating cable circuits.

Chemelex, the U.S. National Electrical Code, and the Canadian Electrical Code require both ground-fault protection of equipment and a grounded metallic covering on all heating cables. All Raychem products meet the metallic covering requirement. Raychem series electronic monitoring controllers incorporate adjustable ground-fault protection, eliminating the need for separate ground-fault breakers.

 **WARNING:** To minimize the danger of fire from sustained electrical arcing if the heating cable is damaged or improperly installed, and to comply with Chemelex requirements, agency certifications, and national electrical codes, ground-fault equipment protection must be used on each heating cable branch circuit. Arcing may not be stopped by conventional circuit breakers. (See code for exceptions.)

 **WARNING:** Disconnect all power before making connections to the heating cable.



**Important:** Contact Chemelex for installation details for low voltage applications where a step-down transformer is used to provide power to the heating cable.

# 7

## Power Supply and Electrical Protection

---

### 7.3 Temperature Controller Wiring

Wiring diagrams for typical temperature controllers are supplied with the controller. A contactor may be used to switch loads greater than the maximum current or voltage rating of the controller. Contact Chemelex for details.

Contactor current ratings: Always ensure that current ratings of the switch contacts are not exceeded. Inrush current may be higher than normal operating current, particularly with copper conductor heating cables.

# 8

## Commissioning and Preventive Maintenance

---

Chemelex requires a series of tests be performed on the heat-tracing system upon commissioning. These tests are also recommended at regular intervals for preventive maintenance. Record and maintain results for the life of the system, utilizing the Heating Cable Commissioning Record (refer to Section 11).

### 8.1 Tests

A brief description of each test is found below. Detailed test procedures are found in Section 9.

#### Visual inspection

Visually inspect the pipe, insulation, and connections to the heating cable for physical damage. Check that no moisture is present in junction boxes, electrical connections are tight and grounded, insulation is dry and sealed, and control and monitoring systems are operational and properly set. Damaged heating cable must be repaired or replaced.

#### Continuity and insulation resistance

Continuity and insulation resistance testing are recommended at four stages during the installation process, and as part of regular system inspection, and after any maintenance or repair work. Continuity testing checks the integrity of the resistive heating element inside the heating cable. IR testing checks the integrity of the electrical insulating barrier between the resistive heating element and the cable sheath. IR testing is analogous to pressure testing a pipe and detects damage to the heating cable sheath or terminations. IR testing can also be used to isolate the damage to a single run of heating cable. Fault location can be used to further locate damage.

#### Power check

##### Line-sensing controlled systems

Check circuit breaker sizing and the supply voltage to make sure that it is suitable for the heating cable voltage rating and amperage printed on the heating cable identification tag.

# 8

## Commissioning and Preventive Maintenance

- Turn on the main circuit breaker.
- Turn on the branch circuit breakers.
- Set the temperature controller or thermostat to the desired control temperature, or to a setting high enough to turn the circuit on if the pipe temperature is above the control temperature.
- Allow the system to reach the control point and the current to stabilize. This may take several hours for some circuits.
- Measure the voltage and pipe temperature for each circuit and record the values in the Heating Cable Commissioning Record (refer to Section 11). This information is needed for future maintenance and troubleshooting.
- Measure the circuit current using a clamp-on or panel ammeter. The measured value should be approximately the number shown under “Amps” on the heating cable identification tag. Variations of 10% to 20% are possible due to deviations in measurement equipment, supply voltage, and cable resistance. Record the values in the Heating Cable Commissioning Record in Section 11.
- When the system is completely checked out, reset the temperature controller to the proper temperature.

The heating cable power (wattage) can be calculated by multiplying the measured voltage by the measured current using the following formula:

$$\text{Power (W)} = \text{Volts (Vac)} \times \text{Current (A)}$$

The calculated wattage can be compared to the wattage indicated on the heating cable tag at the temperature of operation. This gives a good indication of heating cable performance.

### Control and monitoring systems

Refer to the installation instructions supplied with the product for commissioning tests and records.



**Important: The current and resistance of some MI heating cables can vary with temperature. Higher maintain temperatures may result in higher cable resistances and decreased current.**

# 8

## Commissioning and Preventive Maintenance

---

### Ground-fault test

Test all ground-fault breakers per manufacturer's instructions.

### 8.2 Preventive Maintenance

Recommended maintenance for Chemelex heat-tracing systems consists of performing the commissioning tests on a regular basis, preferably at least once a year, unless a Raychem series electronic monitoring controller is used. These controllers automatically exercise and monitor the heating cable circuit for faults. Systems that use electro-mechanical thermostats for control should be checked before each winter.

If the heat-tracing system is found to be defective, refer to Section 10 for troubleshooting assistance. Make the necessary repairs and replace any part of the heat-tracing system if it has been found to be defective.

De-energize all circuits that may be affected by maintenance.

Protect the heating cable from mechanical or thermal damage during maintenance work.

The recommended cable installation methods allow for extra cable at all pipe fixtures (such as valves, pumps, and pressure gauges) so that cable does not have to be cut when performing maintenance work.

### Maintenance records

Chemelex recommends that the Maintenance Log Record (refer to Section 11) be completed during all inspections and kept for future reference.

# 8

## Commissioning and Preventive Maintenance

### Repairs

Use only Raychem MI cable and components when replacing any damaged cable. Repairs should be performed only by qualified personnel and to Chemelex requirements. Replace the thermal insulation to original condition or replace with new insulation, if damaged.

Retest the system after repairs.

 **WARNING:** Damage to cables or components can cause sustained electrical arcing or fire. Do not energize cables that have been damaged. Damaged heating cable or terminations must be repaired or replaced. Damaged cable should be repaired by a qualified person.

 **WARNING:** Heating cables are capable of reaching high temperatures during operation and can cause burns when touched. Avoid contact when cables are powered. Insulate the pipe before energizing the cable. Use only properly trained personnel.

# 9

## Test Procedures

---

Chemelex recommends that the Heating Cable Installation Record be completed during testing and kept for future reference.

### 9.1 Visual Inspection

- Visually inspect the pipe and connections to the heating cable for physical damage. Damaged heating cable must be repaired or replaced.
- Check that electrical connections are tight and grounded.
- Check that the heating cable sheath temperature is appropriate for the area classification and Temperature Class (T-code).
- Ensure that the heating cable carries the correct circuit identification and that there have been no unauthorized modifications to the heating cables.
- Verify that all junction boxes are appropriate for the area classification and correctly sealed with no moisture inside. Ensure that the cable gland connectors are tight and correctly fitted into junction boxes.
- Check for damage to cold lead and inspect glands for worn or galled threads. The use of a thread lubricant on threads between gland backnut and body is recommended with stainless steel glands.
- Check for damaged or wet thermal insulation, damaged, missing or cracked lagging and weather-proofing.
- Check control and monitoring systems for moisture, corrosion, setpoint, switch operation, sensor or capillary damage, and ensure that they are operational and properly set.
- Check circuit breaker sizing and the supply voltage to make sure that it is suitable for the heating cable voltage rating printed on the cable tag.

### 9.2 Insulation Resistance Test – Test 1

Insulation resistance is measured between the heating cable sheath and the tails. Chemelex recommends that the insulation resistance test be conducted using a test voltage of 1000 Vdc, however in the absence of equipment with this capability, a 500 Vdc test is suitable to detect most installation related concerns.

# 9

## Test Procedures

---

### Frequency

Insulation resistance testing is recommended at four stages during the installation process and as part of regularly scheduled maintenance.

- Before installing the cable – minimum 100 megohms
- Before installing the thermal insulation – minimum 20 megohms
- After installing the thermal insulation – minimum 20 megohms
- Prior to initial start-up (commissioning) – minimum 10 megohms \*including branch circuit wiring.
- As part of the regular system inspection
- After any maintenance or repair work
  - \* Under adverse weather conditions, or when the tails or connections have evidence of moisture, lower insulation resistances may be encountered. Refer to Section 10 for corrective actions.

### Test Criteria

The minimum insulation resistance for a clean, dry, properly installed circuit should reflect the values shown above, regardless of the heating cable length.

### 9.3 Continuity (Resistance) Test – Test 2

Continuity testing is conducted using a standard Digital Multimeter (DMM) and measures the resistance between the cold lead tails.

#### Test Criteria

Measure the resistance of the MI heating cable with the DMM. Most MI heating cable resistances are less than 100 ohms. The approximate resistance can be calculated using the formula: Resistance (ohms) = Volts<sup>2</sup> / Watts. Voltage and wattage can be found on the heating cable identification tag.



**Important: This measured value is the resistance at 20°C; the calculated value is the resistance at the operating temperature and may be higher than the measured value.**

# 9

## Test Procedures

---

### 9.4 Insulation Resistance and Continuity Test

1. De-energize the circuit.
2. Disconnect the temperature controller or thermostat if installed.
3. Disconnect tails from terminal block, if installed.
4. Set megohmmeter test voltage at 0 Vdc.
5. Connect the positive (+) lead to the heating cable sheath.
6. Connect the negative (-) lead to both heating cable tails simultaneously.
7. Turn on the megohmmeter and set the voltage to 1000 Vdc; apply the voltage for 1 minute. Meter needle should stop moving. Rapid deflection indicates a short. Record the insulation resistance value in the Heating Cable Installation Record (Section 11).
8. Turn off the megohmmeter.
9. If the megohmmeter does not self-discharge, discharge phase connection to ground with a suitable grounding rod. Disconnect the megohmmeter.
10. Check the continuity (resistance) of the heating cable between the two tails. Record the resistance value in the Heating Cable Installation Record.
11. Disconnect the multimeter.
12. Reconnect heating cable tails to terminal block.
13. Reconnect the temperature controller or thermostat.

If the heating cable fails the insulation resistance test, stop and follow the troubleshooting instructions in Section 10. If it fails the continuity (resistance) test, it is most likely defective and must be repaired.



**WARNING: Fire hazard in hazardous locations. Insulation resistance tests can produce sparks. Be sure there are no flammable vapors in the area before performing this test.**

# 9

## Test Procedures

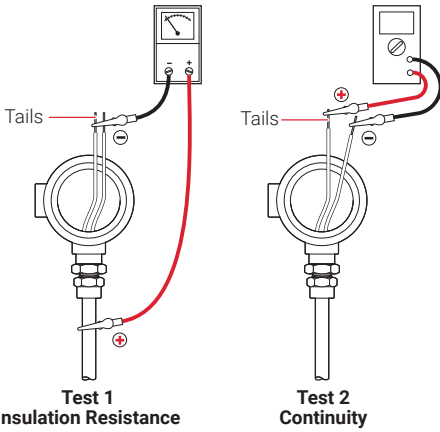

**Figure 32: Connecting the megohmmeter and multimeter**

# 9

## Test Procedures

---

# 10

## Troubleshooting Guide

---

### Symptom

### Probable Causes

---

Insulation resistance less than expected

1. Rain, high humidity or adverse weather conditions.
2. Nicks or cuts in heating cable sheath, with moisture present.
3. Kinked or crushed heating cable.
4. Arcing created by damage to the heating cable.
5. Physical damage to heating cable is causing a direct short.
6. Presence of moisture in terminations or connections.
7. Damaged termination.

---

### Symptom

### Probable Causes

---

Circuit breaker trips

1. Circuit breaker undersized.
2. Defective circuit breaker.
3. Short circuit in electrical connections.
4. Excessive moisture in connection boxes.
5. Nicks or cuts in heating cable sheath, moisture present.
6. Kinked or crushed heating cable.
7. Ground-fault protection device (GFPD) is undersized (5mA used instead of 30mA) or miswired.

**Note:** If the corrective actions above do not resolve the problem, verify that the installation is as per design.

# 10 Troubleshooting Guide

---

## Corrective Action

---

- (1) Dry tails and face of seal. Inspect power connection box for moisture or signs of tracking. Dry out connections and retest.
- (2, 3, 4) Visually inspect cable for damage, especially at elbows, flanges, and around valves. If damaged, repair or replace heating cable. Inspect power connection box for moisture or signs of tracking. Dry out connections and retest.
- (5) Check for visual indications of damage around the valves, pump, and any area where there may have been maintenance work. Look for crushed or damaged insulation along the pipe. Replace damaged sections of heating cable.
- (6) Dry out cold lead and/or connections and replace termination if necessary.
- (7) Replace termination

## Corrective Action

---

- (1) Recalculate circuit load current. Resize breaker as required.
- (2) Repair or replace breaker.
- (3, 4) Eliminate short circuit. Thoroughly dry connections. Install conduit drains as required.
- (5, 6) Repair damaged section or replace heating cable.
- (7) Replace undersized GFPD with 30mA GFPD. Check the GFPD wiring instructions.

# 10

## Troubleshooting Guide

---

### Symptom

### Probable Causes

---

Power output appears correct but pipe temperature is below design maintain temperature.

1. Wet or missing insulation.
2. Insufficient heating cable on valves, flanges, supports, pumps, and other components.
3. Temperature controller set incorrectly.
4. Improper thermal design used.
5. Temperature sensor in wrong location.
6. Low fluid temperature entering pipe.

---

### Symptom

### Probable Causes

---

Power output is zero or incorrect

1. No input voltage.
2. Temperature controller wired in the normally open (N.O) position.
3. Broken or damaged heating element, hot-cold joint, end cap, or broken tail.
4. Wrong cable used.
5. Improper voltage used.

**Note:** If the corrective actions above do not resolve the problem, verify that the installation is as per design.

# 10 Troubleshooting Guide

---

## Corrective Action

---

- (1) Remove wet insulation and replace with dry insulation and secure it with proper weather-proofing.
- (2) Confirm compliance with system design. (If valve, flange, and pipe support types and quantities have changed, additional heating cable may be required.)
- (3) Reset temperature controller.
- (4) Contact your Chemelex representative to confirm the design and modify as recommended.
- (5) Confirm that sensor is in the correct location.
- (6) Verify temperature of fluid entering pipe.

## Corrective Action

---

- (1) Repair electrical supply lines and equipment.
- (2) Confirm wiring using the normally closed (N.C.) terminals so that contacts close with falling temperature.
- (3) Repair or replace heating cable.
- (4) Verify installation as per design and replace cable if necessary.
- (5) Verify voltage and connect to proper voltage if necessary.

# 11

## Installation and Inspection Records

### Heating Cable Installation Record

Location \_\_\_\_\_ Ref. drawings(s) \_\_\_\_\_

Line number \_\_\_\_\_ Heating cable number \_\_\_\_\_

Panel number \_\_\_\_\_ Breaker number \_\_\_\_\_

Heating cable manufacturer \_\_\_\_\_ Heating cable model \_\_\_\_\_

Heating cable wattage unit length / voltage rating \_\_\_\_\_

Megohmmeter manufacturer / model \_\_\_\_\_

Megohmmeter date of last calibration \_\_\_\_\_

Multimeter manufacturer / model \_\_\_\_\_

#### TESTING:

**Note:** Minimum acceptable insulation resistance shall be 20 megohms.

Recommended test voltage is 1000 Vdc.

#### 1. Receipt of material

Continuity test

Insulation resistance test

#### 2. Before installing cable on pipe

Continuity test

Insulation resistance test

#### 3. After installation

Continuity test

Insulation resistance test

#### 4. Visual inspection before installing thermal insulation

Heating cable correctly installed on pipe, vessel or equipment

Heating cable correctly installed at valves, pipe supports, other components

Junction boxes correctly installed and cable terminated

Installation agrees with manufacturers instructions and circuit design

#### 5. Thermal insulation installation complete

Continuity test

Insulation resistance test

#### 6. Tagging and identification complete (panel, field components, pipe decal)

#### 7. Heating cable effectively grounded

#### 8. Temperature controls properly installed and setpoints verified

#### 9. Thermal insulation weather tight (all penetrations sealed)

#### 10. Covered hot-cold joints and end caps marked on insulation outer cladding

#### 11. Drawings, documentation marked as-built

Performed by \_\_\_\_\_

Witnessed by \_\_\_\_\_

Accepted by \_\_\_\_\_



# 11

## Installation and Inspection Records

### Installation Record Required for Class I, Division 1, Hazardous Locations According to IEEE 515

Location

System/Project number

#### **CIRCUIT ID #**

##### **Area:**

Auto ignition temperature

Group classification

##### **HEATING CABLE CIRCUIT:**

Heating cable type

Supply voltage

Circuit length

Design maximum pipe temperature

Heating cable temp code/sheath temp. (from tag)  
(T-rating)

##### **COMPONENTS:**

Junction boxes

##### **GROUND-FAULT PROTECTION:**

Make & model

Ground leakage

Trip level (ma)

##### **INSTALLATION INSTRUCTIONS:**

Correct components per manufacturer's specification

Ground-fault protection device tested

##### **INSULATION RESISTANCE TESTING:** Instrument used

Calibration date

Megohmmeter test voltage  
(1000 Vdc recommended)

Insulation resistance reading before thermal insulation installed  
(minimum insulation resistance shall be 20 megohms)

Insulation resistance reading after thermal insulation installed  
(minimum insulation resistance shall be 20 megohms)

##### **CIRCUIT READY TO COMMISSION:**

Prepared by

Approved by



# 11

# Installation and Inspection Records

## Heating Cable Commissioning Record

Location \_\_\_\_\_ System \_\_\_\_\_

Heating cable number \_\_\_\_\_ Line number \_\_\_\_\_

Panel number \_\_\_\_\_ Location \_\_\_\_\_

Heating cable manufacturer \_\_\_\_\_ Heating cable model \_\_\_\_\_

### DESIGN INFORMATION:

Total design length \_\_\_\_\_

Thermal insulation type \_\_\_\_\_

Normal pipe temperature \_\_\_\_\_

### HEATING CABLE TESTING:

Continuity/Resistance value (Ohms) \_\_\_\_\_

Insulation Resistance value (10 megohms minimum) \_\_\_\_\_

Test ambient temperature \_\_\_\_\_

### PERFORMANCE DATA:

	Volts AC		
	Panel	Field	
Startup			
Second test			
Third test			

Ambient temperature at time of test \_\_\_\_\_

Pipe temperature at beginning of test \_\_\_\_\_

Calculated watts per unit length (Volt x Amp / Length) \_\_\_\_\_

### TEMPERATURE CONTROL: type

Controller \_\_\_\_\_ Ambient sensing \_\_\_\_\_

High limit controller \_\_\_\_\_ Type \_\_\_\_\_

Controls calibrated \_\_\_\_\_

Controls operation verified \_\_\_\_\_

### ALARMS / MONITORING: type

Temperature \_\_\_\_\_ High setting \_\_\_\_\_

Current \_\_\_\_\_ High setting \_\_\_\_\_

Ground-fault current \_\_\_\_\_

Loss of voltage \_\_\_\_\_

Other \_\_\_\_\_

### GROUND-FAULT PROTECTION: type

Setting \_\_\_\_\_ Measured current \_\_\_\_\_

Performed by \_\_\_\_\_

Witnessed by \_\_\_\_\_

Accepted by \_\_\_\_\_

# 11

# Installation and Inspection Records

Project number \_\_\_\_\_ Reference (drawing(s)) \_\_\_\_\_

Area classification \_\_\_\_\_ Autoignition temp. \_\_\_\_\_

Circuit number \_\_\_\_\_ Circuit amp/ voltage \_\_\_\_\_

Heating cable wattage unit length / voltage rating \_\_\_\_\_

Total installed length \_\_\_\_\_

Thermal insulation thickness \_\_\_\_\_

Maintain pipe temperature \_\_\_\_\_

Current in Amperes					
1 phase	3 phase				
Line	A phase	B phase	C phase	Neutral	

After final test \_\_\_\_\_

After final test \_\_\_\_\_

Pipe sensing	Temperature setpoint
Location	Temperature setpoint

Low setting	Operation verified
Low setting	Operation verified
Setting	Operation verified
	Operation verified
	Operation verified

Tested for operation \_\_\_\_\_

Company \_\_\_\_\_ Date \_\_\_\_\_

Company \_\_\_\_\_ Date \_\_\_\_\_

Company \_\_\_\_\_ Date \_\_\_\_\_

# 11

# Installation and Inspection Records

## Maintenance Log Record

Location \_\_\_\_\_ System \_\_\_\_\_

### CIRCUIT INFORMATION

Heating cable catalog. No. \_\_\_\_\_

Breaker panel number \_\_\_\_\_ Breaker number \_\_\_\_\_

Ground-fault protection (type) \_\_\_\_\_

Controller \_\_\_\_\_

### VISUAL

Panel Number	Circuit No.
	Date
	Initial

### Thermal insulation

Damaged insulation/lagging \_\_\_\_\_

Water seal good \_\_\_\_\_

Insulation/lagging missing \_\_\_\_\_

Presence of moisture \_\_\_\_\_

### Heating system components

Enclosures, boxes sealed \_\_\_\_\_

Presence of moisture \_\_\_\_\_

Signs of corrosion \_\_\_\_\_

Heating cable lead discoloration \_\_\_\_\_

### Heating and/or high-limit controller

Operating properly \_\_\_\_\_

Controller setpoint \_\_\_\_\_

### ELECTRICAL

#### Insulation resistance testing (bypass controller if applicable)

Test voltage \_\_\_\_\_

Insulation resistance value (10 megohms minimum) \_\_\_\_\_

#### Heating cable supply voltage

Value at field connection \_\_\_\_\_

#### Heating cable circuit current reading

Amp reading at first test \_\_\_\_\_

Amp reading after second test \_\_\_\_\_

Test ground fault \_\_\_\_\_

Comments and actions: \_\_\_\_\_

Prepared by \_\_\_\_\_ Company \_\_\_\_\_

Approved by \_\_\_\_\_ Company \_\_\_\_\_

# 11

## Installation and Inspection Records

Reference drawing(s) \_\_\_\_\_

Circuit length \_\_\_\_\_

Cable voltage \_\_\_\_\_

Ground-fault trip setting \_\_\_\_\_

Date

Date

## **North America**

Tel +1 800 545 6258  
info@chemelex.com

## **Asia Pacific**

Tel +86 21 2412 1688  
infoAPAC@chemelex.com

## **Europe, Middle East, Africa, India**

Tel +32 16 213 511  
Fax +32 16 213 604  
info@chemelex.com

## **Latin America**

Tel +1 713 868 4800  
info@chemelex.com

---

**chemelex**  
*excellence is everything*

[chemelex.com](http://chemelex.com)

**Raychem Tracer Pyrotenax Nuheat**

©2025 Chemelex. All Chemelex marks and logos are owned or licensed by Chemelex Europe GmbH or its affiliates. All other trademarks are the property of their respective owners. Chemelex reserves the right to change specifications without notice.

RAYCHEM-IM-H57384-MIHeatTracing-EN-2504