

# *Raychem*

## MI Heating Cable System

Installation and Operation Manual for Surface  
Snow Melting

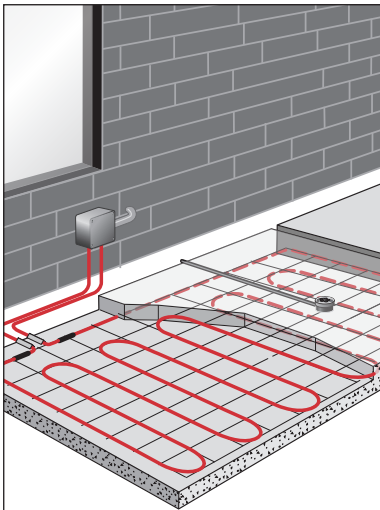

## Important Safeguards and Warnings

### **Warning: Fire and Shock Hazard.**

Raychem Surface Snow Melting Systems must be installed correctly to ensure proper operation and to prevent shock and fire. Read these important warnings and carefully follow all the installation instructions.

- To avoid damage to the heating cables, do not energize cables until they have been completely embedded and the installation has been completed.
- To minimize the danger of fire from sustained electrical arcing if the heating cable is damaged or improperly installed, and to comply with the requirements of Chemelex, agency certifications, and national electrical codes, groundfault equipment protection must be used on each heating cable branch circuit. Arcing may not be stopped by conventional circuit protection.
- Heating cables must be spaced at least ½ in (1.3 cm) from any combustible surface.
- Approvals and performance of the Surface Snow Melting Systems are based on the use of approved components and accessories.
- Cable terminations must be kept dry before, during, and after installation.
- Damaged heating cable can cause electrical arcing or fire. Damaged heating cable or terminations must be repaired or replaced. Contact factory for assistance.
- If the heating cable sheath is stainless steel, the cable must be grounded, but must not be used as the grounding means.
- Reinforcing rod, mesh or other materials used for the support of, or on which the heating cables are installed, must be grounded in accordance with CSA Standard C22.1, Section 10 or the National Electrical Code as applicable.
- Megohmmeters operate at high voltage. This voltage is hazardous and possibly lethal. Read and follow all instructions included with the instrument you are using.

---

<b>1.</b>	<b>General Information</b>	<b>5</b>
1.1	Use of the Manual	5
1.2	MI Applications	6
1.3	Safety Guidelines	6
1.4	Electrical Codes	6
1.5	Approvals	6
1.6	Warranty	7
1.7	Heating Cable Construction	7
1.8	Heating Cable Identification	8
1.9	Heating Cable Catalog Number Decoder	9

---

<b>2.</b>	<b>General Installation Guidelines</b>	<b>10</b>
2.1	Before You Start	10
2.2	Materials Specifications	11
2.3	Heating Cable Storage	11
2.4	Tools Required	11
2.5	Cable Testing Guidelines	11
2.6	Heating Cable Handling	12
2.7	Junction Boxes and Electrical Enclosures	13
2.8	Protecting the Heating Cable	13
2.9	Check Materials Received	14
2.10	Review the Design	14
2.11	Slab Temperature Sensor	18
2.12	Waterproofing Membranes	19
2.13	Drainage and Trench Drains	19
2.14	Visual Inspection	19

---

<b>3.</b>	<b>Heating Cable Installation</b>	<b>21</b>
3.1	Heating Cables Installed in Concrete	21
3.2	Heating Cables Installed in Asphalt	27
3.3	Heating Cables Installed in Mastic Asphalt	30
3.4	Heating Cables Installed Under Brick and Concrete Pavers	34
3.5	Concrete and Asphalt Wheel Tracks	36
3.6	Concrete Stairs	38

---

<b>4.</b>	<b>Accessory Installation</b>	<b>42</b>
4.1	Junction Boxes	42
4.2	Slab Thermostat Installation	49

---

<b>5.</b>	<b>Control, Monitoring and Power Distribution</b>	<b>51</b>
5.1	Manual On/Off Control	51
5.2	Slab Sensing Thermostat	51
5.3	Automatic Snow Controller	51

---

<b>6.</b>	<b>Power Supply and Electrical Protection</b>	<b>53</b>
6.1	Voltage Rating	53
6.2	Circuit Breaker Sizing	53
6.3	Ground-Fault Protection	54
6.4	Junction Box Wiring	54
6.5	Typical Wiring Diagrams	55

---

<b>7.</b>	<b>Commissioning and Preventive Maintenance</b>	<b>62</b>
7.1	System Tests	62
7.2	Preventive Maintenance	63

---

<b>8.</b>	<b>Test Procedures</b>	<b>64</b>
8.1	Visual Inspection	64
8.2	Insulation Resistance Test – Test 1	64
8.3	Continuity (Resistance) Test – Test 2	65
8.4	Insulation Resistance and Continuity Test Procedure	65
8.5	Power Check	66
8.6	Fault Location Testing	69

---

<b>9.</b>	<b>Troubleshooting Guide</b>	<b>70</b>
-----------	------------------------------	-----------

---

<b>10.</b>	<b>Installation and Inspection Records</b>	<b>74</b>
------------	--	-----------

# 1. GENERAL INFORMATION

---

## 1.1 Use of the Manual

This manual covers the installation of Raychem Mineral Insulated (MI) heating cables for surface snow melting in concrete, asphalt, and sand or limestone screenings under paving stones\*.

The manual covers general heating cable installation procedures and specific installation details and provides information on available accessories. The manual also provides information on controls, testing, and periodic maintenance.

This manual assumes that a proper snow melting or anti-icing design has been completed according to Chemelex' recommendations. Only the applications described in this manual are approved by Chemelex for Raychem MI Surface Snow Melting Systems and only when used with approved accessories. The instructions in this manual and the installation instructions included with the control systems, power distribution systems, and accessories must be followed for the Chemelex warranty to apply.

For design assistance, technical support, or information regarding other applications not shown here, please contact your Chemelex representative or Chemelex directly.

### **Chemelex**

Tel: 1.800.545.6258

Email: [Info@chemelex.com](mailto:Info@chemelex.com)

Website: [chemelex.com](http://chemelex.com)



**Important:** For the Chemelex warranty and agency approvals to apply, the instructions that are included in this manual and product packages must be followed.

\* Special permission for paver snow melting is required from the Authority Having Jurisdiction.

## 1.2 MI Applications

### Surface Snow Melting

Surface Snow Melting Systems prevent the accumulation of snow on ramps, slabs, driveways, sidewalks, platform scales, and stairs under typical snow conditions.

### Anti-Icing

Anti-icing systems keep the surface temperature above freezing to prevent ice formation.

## 1.3 Safety Guidelines

As with any electrical equipment, the safety and reliability of any system depends on the quality of the products selected and the manner in which they are installed and maintained. Incorrect design, handling, installation, or maintenance of any of the system components could damage the Surface Snow Melting System and may result in inadequate snow melting, electric shock, or fire. To minimize these risks and to ensure that the system performs reliably, read and carefully follow the information, warnings, and instructions in this guide.

Pay special attention to the following:

Important instructions are marked  **Important**

Warnings are marked  **Warning**

## 1.4 Electrical Codes

Article 426 of the National Electrical Code (NEC) and Section 62 of the Canadian Electrical Code (CEC) govern the installation of fixed outdoor surface snow melting and de-icing systems. All installations must be in compliance with these and any other applicable national and local codes.

## 1.5 Approvals

MI heating cables are approved for use in nonhazardous and hazardous locations.

For a complete list of approvals, refer to the product data sheets available on our web site at [chemelex.com](http://chemelex.com) or contact your Chemelex representative.

- H57796 – MI Heating Cable for Surface Snow Melting – MI data sheet
- H56990 – MI Heating Cable for Commercial Applications data sheet

 **Important:** Types SUA and SUB heating cables are approved for use in nonhazardous areas only.

## 1.6 Warranty

Chemelex' standard limited warranty applies to Surface Snow Melting Systems.



An extension of the limited warranty period to ten (10) years from the date of installation is available, except for the control and distribution systems, if a properly completed online warranty form is submitted within thirty (30) days from the date of installation. You can access the complete warranty on our web site at <https://raychem.chemelex.com/en-us/support/warranty-information>

## 1.7 Heating Cable Construction

The MI heating cables are comprised of one or two conductors surrounded by magnesium oxide insulation and a solid copper or Alloy 825 sheath. Raychem Copper sheath cables are covered with an extruded low-smoke zero-halogen (LSZH) jacket that protects the copper sheath from corrosive elements that can exist in surface snow melting applications. All of the cables include both a heated section (heated length) and a nonheating cold lead section. These sections are joined at the hot/cold joint where the heating element is spliced into larger bus wires. A final transition at the end of the cold lead section provides an environmental seal and tails for the electrical connection. The heating cables are available as factory-terminated configurations shown in Table 1.

**Table 1: MI Heating Cable Configurations**

MI cable design	Number of conductors	Configuration
A (SUA)	Single conductor (61 series)	
B (SUB)	Single conductor (61 series)	
D	Dual conductor (32 & 62 series)	

## 1.8 Heating Cable Identification

Each MI heating cable is supplied with an identification tag on which the heating cable catalog number is permanently printed. In addition to its identification purposes, the catalog number provides information regarding the heating cable length, power output, and operating voltage. Also printed on the tag are the serial number and temperature code. If the cable has been designed for a hazardous location, the area classification is printed in the “Haz. Locations” section of the tag (for custom engineered cables only).



**Important:** If the metal tag is removed during cold lead installation, it must be reinstalled on the cold lead within 3 in (7.5 cm) of the end of the cold lead/power connections.

Figure 1 shows a typical identification tag supplied with pre-engineered SUA/SUB heating cables (SUA1 through SUB22). These heating cables are designed to be used for several different applications depending on the supply voltage selected. In Figure 2, a typical identification tag supplied with custom engineered heating cables is shown.



Figure 1: Typical SUA/SUB MI heating cable identification tag (front)



**Important:** Several SUA and SUB series of heating cables are designed for use on either 208, 240, or 277 volts when used in surface snow melting applications. For these cables, the catalog number printed on the tag will show only the highest voltage to which the cable may be connected, and the highest wattage produced. The wattages produced at other supply voltages are shown in the area below the catalog number and across from the “SNOW MELTING / PS,C” heading (see Figure 1).



Figure 2: Typical custom engineered heating cable identification tag (front)

## 1.9 Heating Cable Catalog Number Decoder

The heating cable catalog number may be broken out as follows:

**B/61RE4300-RD/320/8000/277/15/R30A/Y/N12**

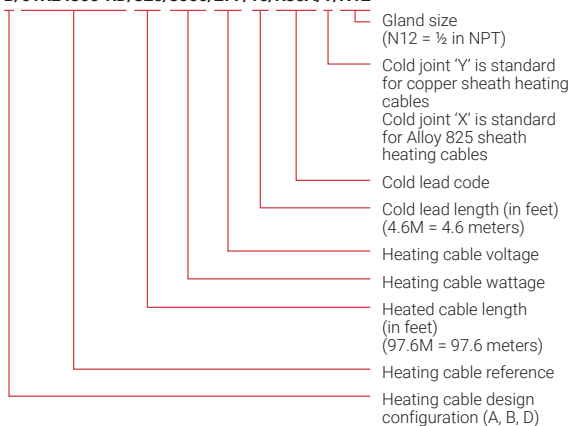

Figure 3: MI heating cable catalog number

## 2. GENERAL INSTALLATION GUIDELINES

---

The guidelines in Section 2 are provided to assist the installer throughout the installation process and should be reviewed before the installation begins.

### 2.1 Before You Start

The Surface Snow Melting System is an engineered system that has been designed for your application. To ensure a smooth, efficient installation and start-up, obtain all the relevant engineering information before commencing work. Contact the general contractor, owner, or owner's representative to obtain a statement of the project design basis, project specifications, and the heating cable layout drawings.

It is important that the heating cable depth and spacing be maintained for proper operation of the system for all concrete, asphalt and paver installations. For sloping ramps, such as a ramp to an underground parking garage, serpentine the cables across the width of the ramp to improve snow melting effectiveness.

To ensure that the installation proceeds smoothly and meets the design objectives, the following questions should be answered.

- What are the exact dimensions of the area to be heated?
- What is the supply voltage and phase?
- Are the heating cables being installed in concrete or asphalt, or if paver area, in limestone screenings or sand?
- Where are the control joints, expansion joints, and construction joints located?
- What is the heating cable spacing?
- Is a waterproof membrane being used?
- What is the depth of burial of the heating cable?
- Where are the junction boxes located?
- Is there adequate drainage for melted snow and ice?



**Important:** Fuel storage areas and aircraft hangar doors are classified as hazardous areas. Heating cables installed in these areas must be approved for the area classification.

## 2.2 Materials Specifications

Install the heating cables in concrete, asphalt, or other materials that have been designed to handle the expected load and environmental conditions, and for long term structural stability. The quality of the granular base materials, concrete, and asphalt must conform to generally accepted standards and specifications set by the American Society for Testing and Materials (ASTM) and/or Canadian Standards Association (CSA). Site preparation and material selection should be done under the direction of the Soil Consultant, Engineer, Architect, or Landscape Architect.

## 2.3 Heating Cable Storage

- Store heating cables in a clean, dry location and protect from mechanical damage. Temperature range:  $-40^{\circ}\text{F}$  to  $140^{\circ}\text{F}$  ( $-40^{\circ}\text{C}$  to  $60^{\circ}\text{C}$ ).
- Store heating cables in their shipping container until ready to install.

## 2.4 Tools Required

The following tools are recommended for installing MI heating cables:

- Pliers
- 1000 Vdc megohmmeter
- Multimeter
- Large adjustable wrench
- Torque wrench
- Pay-off reel (to uncoil long cables)

## 2.5 Cable Testing Guidelines

Insulation resistance (IR) testing is recommended at four stages during the installation process and as part of regularly scheduled maintenance. Further details on IR testing can be found in Section 8.

- When received – minimum 100 M $\Omega$
- After the cables have been installed – minimum 20 M $\Omega$
- Continuously during placement of concrete, asphalt, etc. – minimum 20 M $\Omega$
- Prior to initial start-up (commissioning) – minimum 20 M $\Omega$
- As part of the regular system inspection
- After any maintenance or repair work

## 2.6 Heating Cable Handling

Avoid damage to the MI heating cable as follows:

 **Important:** Do not energize the heating cables before they have been completely embedded and the installation has been completed.

- Use a pay-off reel to uncoil heating cable during installation; do not pull cable out into a spiral (Figure 4).

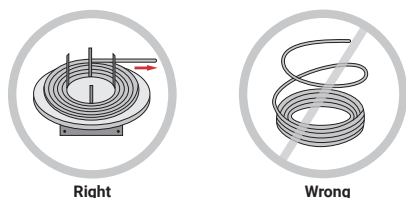

Figure 4: Unreeling/uncoiling cable

- Do not alter cable length.
- Avoid damaging heating cables by cutting or crushing (Figure 5).

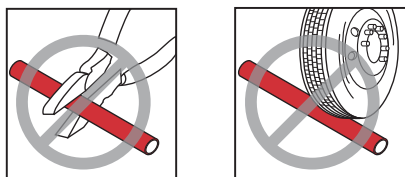

Figure 5: Avoid cutting and crushing the heating cable

- Do not install cables if the temperature is below  $-4^{\circ}\text{F}$  ( $-20^{\circ}\text{C}$ ) for UL, and  $-22^{\circ}\text{F}$  ( $-30^{\circ}\text{C}$ ) for CSA.

 **Important:** Do not install so that heating cables are crossed, overlapped, or grouped (Figure 6). Grouped heating cables can cause localized overheating with a risk of fire or cable failure.



Figure 6: Do not cross, overlap, or group heating cables

- Do not repeatedly bend and straighten the cable.
- Do not install heating cable in contact with insulating materials.
- Install heating cable at the recommended spacing to ensure correct watt density.

- Use a plank to tip wheelbarrow on.
- Handle the hot/cold joint carefully. Support the joint on both sides when moving and positioning the cold lead.
- Position hot/cold joints 6 in (15 cm) in from edge of snow melted area and spaced at least 6 in (15 cm) apart from each other (do not bunch hot/cold joints – see Figure 7).

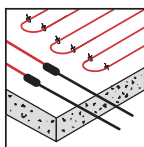

### Right

hot/cold joints  
6 in (15 cm) apart  
and 6 in (15 cm)  
from slab edge

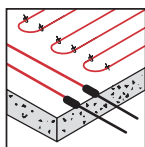

### Wrong

hot/cold joints  
installed on  
slab edge

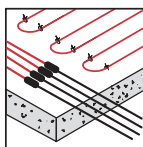

### Wrong

hot/cold joints  
bunched

Figure 7: Positioning hot/cold joints

- During installation, protect tails from breaking where they emerge from brass pot by taping over tails and pot with electrical tape.
- Do not bend the heating cable or cold lead within 6 in (15 cm) of a splice, the hot/cold joint, or the end cap.
- Do not bend cable to an inside radius less than 6 times the outside diameter of the cable.
- Do not space runs of heating cable closer than 3 in (7.5 cm) together.
- Do not use sharp objects such as shovels, rakes, etc. when installing the cable (Figure 8).



Figure 8: Avoid damage by not using shovels or rakes

## 2.7 Junction Boxes and Electrical Enclosures

- Junction boxes and enclosures used for electrical connections to the heating cables must be listed and approved for the environment in which they are installed.
- Junction boxes should be mounted indoors or above grade when possible. For electrical connections made outdoors at grade level, use a handhole type grade mounted enclosure.
- Keep covers on junction boxes to prevent moisture from entering them.

## 2.8 Protecting the Heating Cable

On many projects, there is a delay between installation of the heating cables and placement of the topping course (concrete, asphalt, limestone screenings/sand). If there is any delay at all,

take the following precautions to protect the installation until the heating cables can be completely covered.

- Do not energize the heating cables
- Mechanically protect the heating cables so that they cannot be damaged by being walked on, run over, painted, sandblasted, burned, welded, or cut.

## 2.9 Check Materials Received

Review the project specifications, drawings, and schedules and compare the list of materials to the catalog numbers of heating cables and components received to confirm that proper materials are on site. The heating cable catalog number, voltage, wattage, and length are printed on the metal tag attached to the cold lead.

- Ensure that the heating cable voltage rating is suitable for the power supply voltage available.
- Inspect the heating cable and components for in-transit damage.

## 2.10 Review the Design

Hold a project coordination meeting. Review the design at this meeting and ensure that the cables supplied meet the design requirements and conform to the watt density (watts per square foot/watts per square meter) requirements for the project at the specified cable spacing. This can be verified in conjunction with the MI Surface Snow Melting Design Guide (H57045).

Review the installation steps in Section 3 for the particular application as several trades may be involved in the system installation. Review Section 4 on accessory installation including the location of all junction boxes. During the meeting, discuss the role of each trade and the contractor.

Spacing and watt density may be confirmed as follows:

### English

$$\text{Cable Spacing (in)} = \frac{\text{Heated Area (ft}^2\text{)} \times 12}{\text{Heating Cable Length (ft)}}$$

$$\text{Watt Density (W/ft}^2\text{)} = \frac{\text{Heating Cable Wattage (W)}}{\text{Heated Area (ft}^2\text{)}}$$

### Metric

$$\text{Cable Spacing (cm)} = \frac{\text{Heated Area (m}^2\text{)} \times 100}{\text{Heating Cable Length (m)}}$$

$$\text{Watt Density (W/m}^2\text{)} = \frac{\text{Heating Cable Wattage (W)}}{\text{Heated Area (m}^2\text{)}}$$

For three-phase supply voltages, the total area is generally divided into multiples of three equal subsections, allowing for installation of a single cable in each subsection. Heating cables of the same length and wattage, installed in each subsection, will provide a balanced electrical load. It may not be possible to use a balanced electrical load for small areas, therefore one or two heating cables, single-phase connected, must be used.

Ensure that the cold lead length is sufficient to reach the junction box. The standard cold lead length for pre-engineered (SUB) cables is 15 ft (4.6 m), but heating cables may have been custom designed using longer cold leads. Plan the location of all junction boxes and supply points so that they are located within reach of the heating cable cold leads. Typical junction box installation details are shown in Section 4.

The location of all joints in the ramp or slab should be recorded on the layout drawing. Plan the general layout of the heating cables to avoid crossing control and expansion joints. In some cases, the placement of these joints may have to be relocated in order to divide the area equally since the quantity of heating cables supplied may have been based on equal subsection areas. If necessary, control joints can be crossed using one of the two methods shown in Figure 9. Crossing expansion joints should be avoided, but if this is not possible, use the method shown in Figure 10.

## Types of Joints

**Control joints** are intended to control where the slab will crack. Their exact location is determined by the concrete installers before the concrete is poured. Because of the reinforcement in the base slab, there is rarely a shearing action caused by differential vertical movement between the concrete on either side of the crack. As a precautionary measure, however, either of the two methods of crossing control joints shown in Figure 9 should be used. Minimize the number of times the joint is crossed as shown in Figure 9. When installing cables using the two-pour method, control joints must be placed in both the base slab and the surface slab.



**Warning:** Use caution when saw cutting the control joints to avoid damaging the heating cables. Consult with the electrical contractor or cable installer before cutting or drilling to find out cable depth.

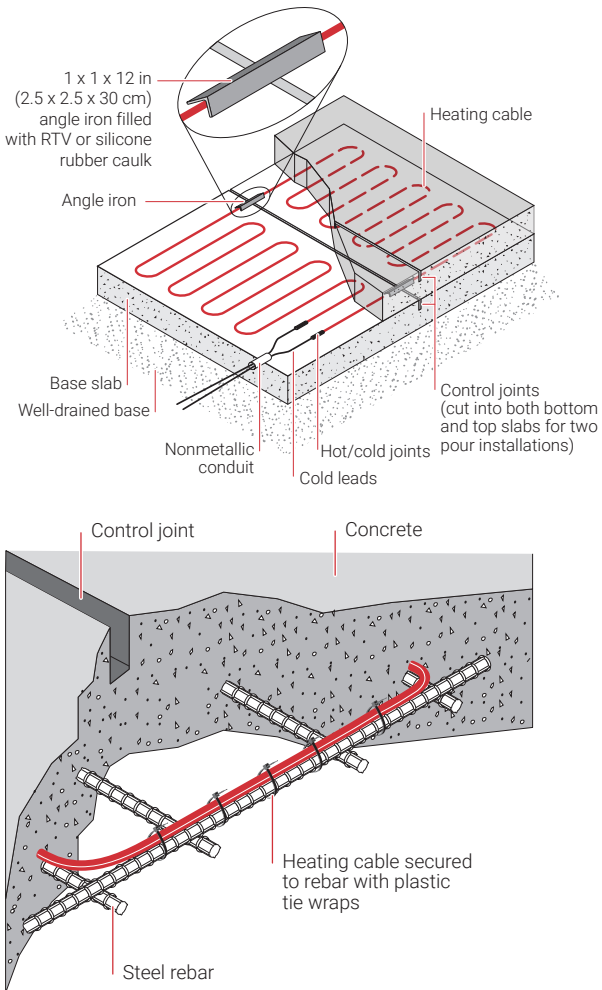

Figure 9: Crossing control joints

Construction joints are joints that occur when the concrete pour is going to stop but will resume at a later date. Therefore, their location may not be known beforehand. However, the reinforcement is left protruding out of the first pour so that it enters the next pour and therefore shearing action rarely occurs due to differential vertical movement between the concrete on either side of the joint. As a precautionary measure, either of the two methods of crossing control joints shown in Figure 9 should be used.

**Expansion joints** are placed where a concrete slab abuts some structure, such as a building, a slab, or a foundation, etc. Because the reinforcement does not cross expansion joints, differential movement will occur between the slab and the

adjoining structure. **Avoid crossing expansion joints with the heating cable.** If this is not possible, expansion joints can be crossed using a sand filled metal box as shown in Figure 10.

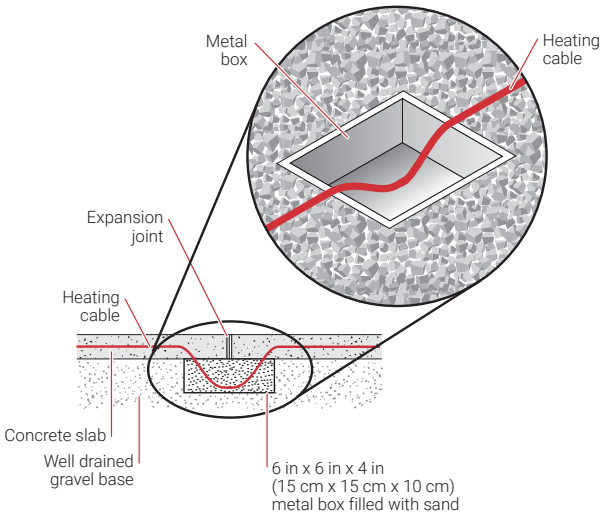

Figure 10: Crossing expansion joints

Refer to the installation instructions in Section 3 for your specific application. This section gives details on the minimum and maximum concrete or asphalt cover required over the heating cables and maximum paver thickness, cable testing requirements during installation, and other specific installation details.

The heating cable should be securely fastened in place every 3 to 4 ft (90 to 122 cm) to maintain the proper spacing and depth below the finished surface. Where the rebar is 2 to 3 in (5 to 7.5 cm) below the finished surface and the rebar spacing does not exceed 12 in (30 cm), the cable can be fastened directly to the rebar using plastic tie wraps. When the rebar spacing exceeds 12 in (30 cm), the heating cables should be fastened to, and supported, on square wire mesh as shown in Figure 11.

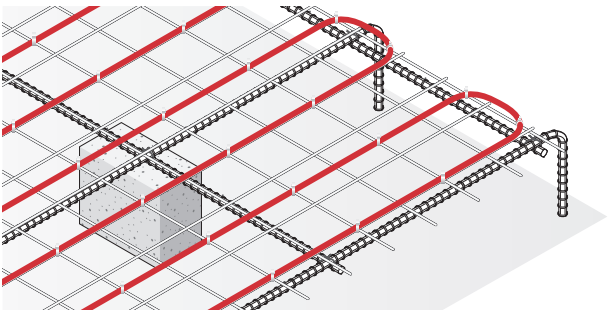

Figure 11: Supporting heating cable when rebar spacing exceeds 12 in (30 cm)

When the heating cables are fastened to a solid base, such as a two-pour concrete or asphalt installation, use prepunched strapping spaced 3 to 4 ft (90 to 122 cm) apart to maintain the cable spacing. The tabs on the strapping should be bent backwards over the cable as shown in Figure 12.

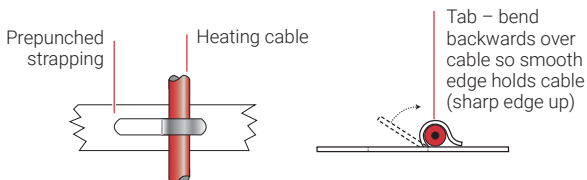

Figure 12: Method of bending tabs on prepunched strapping

## 2.11 Slab Temperature Sensor

To prevent the heating cable from being energized during warm weather and for improved energy efficiency, use a separate slab sensing thermostat or the integral temperature sensor supplied with the automatic snow melting control panel. The temperature sensor should be installed in metal conduit secured between two runs of heating cable. Do not allow the conduit to touch the heating cable. Cap the buried end of the conduit so that it is watertight. Ensure that the sensor can fit past all bends in the conduit prior to installation of the conduit. The conduit should be long enough to extend out to approximately the middle of the area being heated.

If the slab temperature sensor is integral to the snow melting controller or control panel, the sensor should be installed in minimum  $\frac{1}{2}$  in (1.3 cm) conduit secured between two runs of heating cable (see Section 3), but as an alternative, a short piece of flexible conduit may be connected to the pavement mounted sensor, installed midway between two runs of cable as shown in Figure 13.

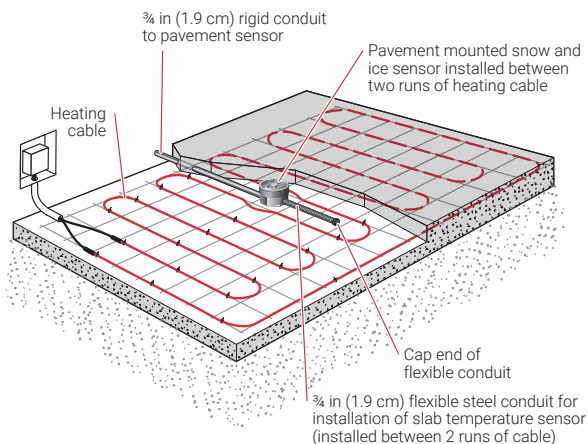

Figure 13: Alternative slab temperature sensor installation

## 2.12 Waterproofing Membranes

Certain precautions must be observed when installing heating cables on slabs that use waterproofing membranes.

- If it is necessary to penetrate the membrane, follow the membrane manufacturer's recommendations.
- Do not install the heating cables directly on top of the membrane. Cables must be attached to a mesh and elevated at least ½ in (1.3 cm) above the membrane surface while maintaining the recommended thickness of covering over the cables. Attach the cables to the mesh using plastic tie wraps (do not use wire).
- The structural engineer should be consulted to ensure that the top placement of concrete is designed to handle the stresses imposed by vehicular traffic (additional reinforcing may be required).

## 2.13 Drainage and Trench Drains

Concrete trench drains are typically heated using a separate heating cable embedded in the concrete base of the trench drain. The heating cable is usually connected to a separate electrical circuit and terminated in a separate junction box.

The cable installation generally consists of two or more runs of cable run back and forth along the length of the trench drain. Follow the installation instructions in Section 3.1 for installing the heating cables in concrete.



**Important:** For trench drains made of composite materials, contact Chemelex technical support.

## 2.14 Visual Inspection

A visual inspection of the Surface Snow Melting System should be made before placement of the concrete, asphalt, or limestone screenings/sand to ensure proper installation of the system.

- Verify that there is no mechanical damage to the heating cables (cuts, breaks, burns, scrapes, etc.).
- Verify proper heating cable spacing and depth for the application.
- Verify proper heating cable fastening method (no wire).
- If crossing control or expansion joints could not be avoided, ensure that control joints are crossed as shown in Figure 9 and expansion joints crossed as shown in Figure 10.
- Verify that the cold leads are protected with nonmetallic conduit where they emerge from the heated slab.
- Verify that the hot/cold joints are 6 in (15 cm) in from the edge of snow melted area, are not bunched together, and spaced at least 6 in (15 cm) apart from each other (see Figure 7).
- Verify that the junction boxes are properly installed per manufacturer's instructions and the details in Section 4.

 **Warning:** Damaged heating cable can cause arcing or fire. Do not energize damaged heating cable; repair or replace it.

For installation assistance or technical support, please contact your Chemelex representative or Chemelex directly at (800) 545-6258.

### 3. HEATING CABLE INSTALLATION

---

This section provides instructions for installing the heating cables in concrete, asphalt, mastic asphalt, and for brick and concrete paver applications. The system being installed should have already been designed using the MI Surface Snow Melting Design Guide (H57045). Read and follow these instructions to ensure that the system performs reliably and as intended.

- Section 3.1 covers heating cable installation in concrete
- Section 3.2 covers heating cable installation in asphalt
- Section 3.3 covers heating cable installation in mastic asphalt
- Section 3.4 covers heating cable installation for brick and concrete paver areas
- Section 3.5 covers heating cable installation in concrete and asphalt wheel tracks
- Section 3.6 covers heating cable installation in concrete stairs

#### 3.1 Heating Cables Installed in Concrete

These instructions show how to install MI snow melting heating cables for single-pour or two-pour concrete installations.

In single-pour installations, the cables are attached to the reinforcing mesh or rebar and covered with a single concrete pour. In a two-pour installation, the heating cables are attached to a reinforced concrete base pour that has been allowed to set and then covered with a second concrete pour.

Review and understand the technical requirements in Section 2 prior to installing the heating cables. Follow the appropriate instructions in each step, where shown, for a single-pour or two-pour installation. Where a step does not differentiate between a single-pour or two-pour installation, the instructions are common to both.



**Important:** Reinforcement is necessary to ensure that the concrete is structurally sound. Concrete that cracks, crumbles, or settles can damage the heating cable. The reinforcement must be adequately supported so that it is not disturbed by the installation. It is important that the heating cable depth in the concrete be maintained for proper operation of the system.

1. **Single-pour:** Mark the location of control and/or expansion joints on the edge forms and on the heating cable layout drawings. Refer to Section 2.1 for details and recommendations on placing and crossing control and expansion joints.

**Two-pour:** Cut control joints into the base slab at the required intervals, usually 20 ft (6.1 m) intervals or less in any direction (this will usually depend on the number of heating cables being installed). Mark the location of control and/or expansion joints on the edge forms and on the heating cable layout drawings so that the upper control joints can be cut into the second concrete pour at the correct locations. Cross control joints as shown in Section 2.10. Do not cross expansion joints.



**Important:** In two-pour installations it is desirable to make the base slab and topping course truly monolithic since the majority of recorded cable damage is a result of slabs becoming delaminated and shifting. The surface of the base slab must be properly cleaned and prepared to allow the topping pour to bond to the base slab. Use an appropriate method for proper bonding or consult with the structural engineer.

2. Install the junction boxes. For single conductor cables, the cable layout should begin and end at or close to the junction box to allow the cold leads to be fed back to the junction box. Section 4 shows several typical installation methods for junction boxes.
3. **Single-pour:** If supporting cable on the reinforcement, ensure that the concrete thickness over the heating cable will be 2 in (5 cm) minimum to 3 in (7.5 cm) maximum; otherwise, the cable must be supported on mesh elevated above the reinforcement. If using fiber reinforced concrete, the heating cable must be supported on a mesh such that the concrete thickness over the cable will be 2 in (5 cm) minimum to 3 in (7.5 cm) maximum. Refer to Section 2.1 and Figure 14 for further details.



**Important:** If a herringbone pattern is to be cut into the concrete surface (Figure 16), adjust the depths of the cable supports (see Step 10 for details).



**Important:** The NEC allows 1-½ in (3.8 cm) minimum covering over cables, however 2 in (5 cm) minimum is recommended to help prevent damage to the heating cable by ensuring that it will be fully embedded in the concrete in case the concrete spalls. In Canada, the CEC requires 2 in (5 cm) minimum concrete cover over the cables.

**Two-pour:** Install prepunched strapping at 3 to 4 ft (0.9 to 1.2 m) intervals with additional runs, where required, to hold cable loops securely. Fasten the strapping in place using an appropriate fastening method (see Figure 15).



**Important:** If a herringbone pattern is to be cut into the concrete surface (Figure 16), ensure that the minimum concrete cover over the heating cables is maintained (see Step 10 for details).



**Important:** If a waterproofing membrane has been placed over the base slab, the heating cables must be installed on a reinforcing mesh elevated not less than ½ in (1.3 cm) above the membrane surface. Use plastic tie wraps to secure the cable to the mesh (do not use wire).

4. **Single-pour:** Lay out the heating cable in a serpentine pattern on top of the reinforcement/mesh and fasten in place with plastic tie wraps (do not use wire), at the predetermined spacing, ensuring that the watt density is as specified in the design requirements (see Section 2.1). Typical cable spacing ranges between 3 in (7.5 cm) minimum to 10 in (25 cm) maximum on centers. For sloping ramps, such as a ramp to an underground parking garage, serpentine the cables across the width of the ramp to improve snow melting effectiveness. Stay at least 6 in (15 cm) from edges and outer walls (see Figure 14). Refer to Section 2.1 if crossing control and expansion joints.



**Important:** If a herringbone pattern is to be cut into the concrete surface (Figure 16), follow the guidelines in Step 10 when laying out the heating cable.



**Important:** The heating cable spacing may have to be adjusted to ensure uniform coverage over the area to be heated.

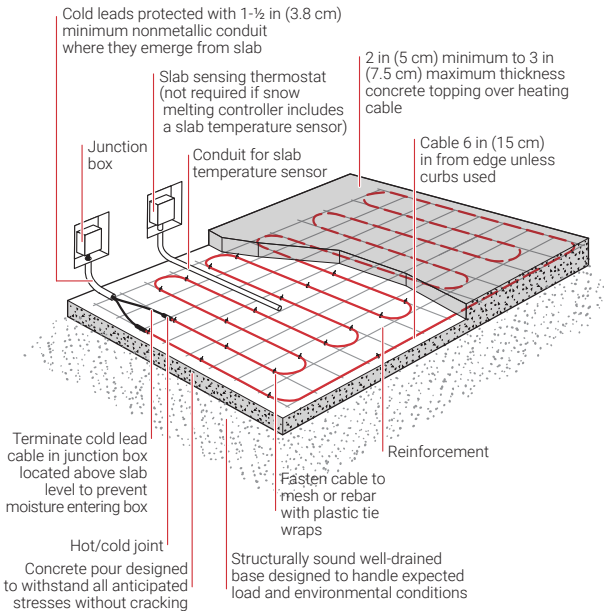

Figure 14: Single-pour concrete

**Two-pour:** Lay out the heating cable in a serpentine pattern and fasten the cable to the prepunched strapping (or mesh if a waterproofing membrane was installed), at the predetermined spacing, ensuring the watt density is as specified in the design requirements (see Section 2.10). It is recommended that the tabs on the prepunched strapping be bent backwards over the cable as shown in Figure 12. Typical cable spacing ranges between 3 in (7.5 cm) minimum to 10 in (25 cm) maximum on

centers. For sloping ramps, such as a ramp to an underground parking garage, serpentine the cables across the width of the ramp to improve snow melting effectiveness. Stay at least 6 in (15 cm) from edges and outer walls (see Figure 15 for details). Refer to Section 2.10 if crossing control joints.

**Important:** If a herringbone pattern is to be cut into the concrete surface (Figure 16), follow the guidelines in Step 10 when laying out the heating cable.

**Important:** The heating cable spacing may have to be adjusted to ensure uniform coverage over the area to be heated.

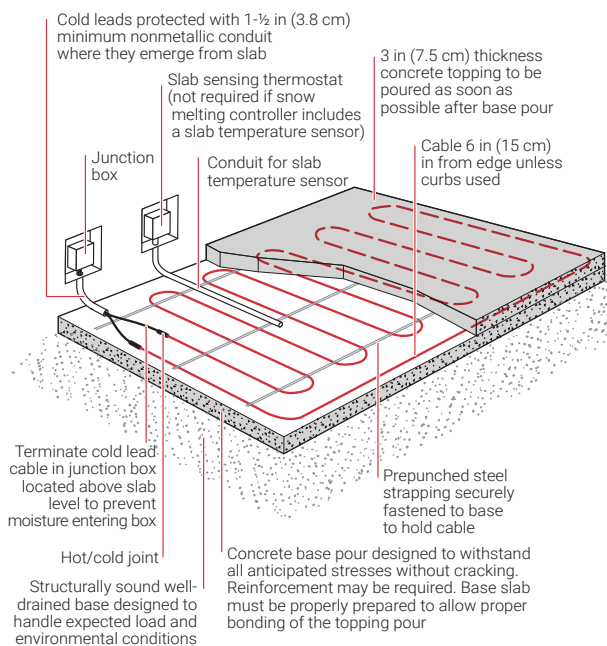

Figure 15: Two-pour concrete

5. Install the hot/cold joints so that they are at least 6 in (15 cm) in from the edge of the slab, ensuring that they will be completely embedded in the concrete (see Section 2.6). Protect the cold leads with nonmetallic conduit where they emerge from the slab (see Figure 14 and Figure 15 and Section 4 for details).
6. Install the conduit for the slab temperature sensor (see Section 2.11 for details).

**Important:** Do not install the temperature sensor at this time.

7. Visually inspect the heating cables, cold leads, and junction boxes (see Section 2.14) and record the results in the Surface Snow Melting Installation Record in Section 10.
8. Before the concrete is poured, check the insulation resistance of all heating cables to verify that the cables were not damaged during installation. Details on testing can be found in Section 8. Minimum acceptable IR is 20 MΩ at 1000 Vdc. Record the results of the tests in the Surface Snow Melting Installation Record in Section 10.
9. **Single-pour:** Pour the concrete and ensure that it is thoroughly consolidated with a high frequency vibrator. Continuously check the insulation resistance of the heating cables to verify that the cables are not damaged during the concrete pour – minimum acceptable IR is 20 MΩ at 1000 Vdc. Ensure that the concrete cover over the heating cables is a minimum thickness of 2 in (5 cm) to 3 in (7.5 cm) maximum (Figure 14). Ensure that the concrete depth over the heating cables is maintained if using a herringbone pattern (see Step 10).



**Important:** Take precautions to protect the heating cable during the concrete pour. Do not use sharp tools such as rakes, shovels, etc. that might damage the heating cable. Do not strike the heating cable with tools, walk on the heating cable, or do anything else that will damage the heating cable.



**Important:** If a cable is damaged during the concrete pour, the insulation resistance will immediately decrease. The pour should be stopped and a small wooden box built around the damaged section. Pouring can then continue and repairs made after the concrete sets up.

**Two-pour:** Pour a 3 in (7.5 cm) thick concrete topping over the heating cables and ensure that it is thoroughly consolidated with a high frequency vibrator. Continuously check the insulation resistance of the heating cables to verify that the cables are not damaged during the concrete pour – minimum acceptable IR is 20 MΩ at 1000 Vdc. The concrete cover over the heating cables must be structurally sound and must properly adhere to the base slab to prevent delamination between the slabs. Ensure that the concrete depth over the heating cables is maintained if using a herringbone pattern (see Step 10).



**Important:** Take precautions to protect the heating cable during the concrete pour. Do not use sharp tools such as rakes, shovels, etc. that might damage the heating cable. Do not strike the heating cable with tools, walk on the heating cable, or do anything else that will damage the heating cable.



**Important:** If the cable is damaged during the concrete pour, the insulation resistance will immediately decrease. The pour should be stopped and a small wooden box built around the damaged section. Pouring can then continue and repairs made after the concrete sets up.

10. If a herringbone pattern will be cut into the concrete surface, observe the following:
  - Install the heating cables as shown in Figure 16. Ensure that each heating cable does not cross the center herringbone cut more than two times. This will prevent cable damage due to cracking along the center herringbone cut, the area most likely to crack.
  - Ensure that the minimum concrete cover is maintained over the cables – the thickness of concrete from the bottom of the herringbone cut to the top of the cables should not be less than 2 inches and must not exceed 3 in (7.5 cm). The level of the reinforcement/mesh may have to be adjusted to maintain the required concrete thickness over the cables.

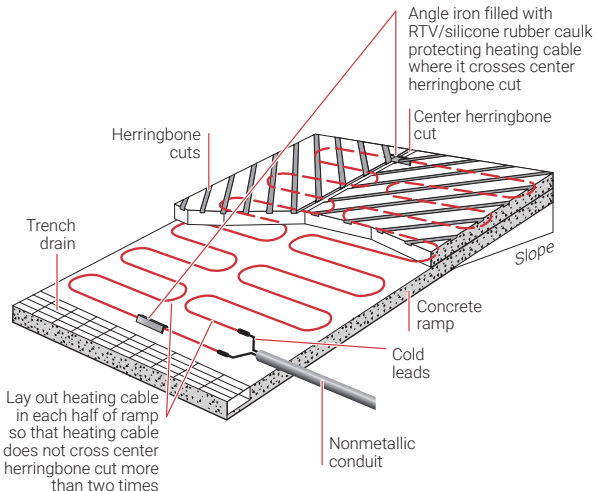

Figure 16: Recommended cable layout when herringbone pattern will be cut into the concrete surface

11. Allow the concrete to cure following the specifications in the contract documents.



**Important:** Use caution when saw cutting the control joints to avoid damaging the heating cables. Consult with the electrical contractor or cable installer before cutting or drilling to find out cable depth.

12. Do not energize the heating cables during the curing period. Do not allow traffic on the new completed surface until adequate stability has been attained and the material has cured sufficiently.

13. Ensure drainage will be adequate for run-off of melted snow and ice.
14. Connect the cold leads to the junction box.
15. The slab temperature sensor can be installed at any time after the concrete installation has been completed. Refer to Section 4 for details.

### 3.2 Heating Cables Installed in Asphalt

These instructions show how to install MI snow melting heating cables for asphalt areas. Heating cables may be installed directly on an asphalt base. When asphalt will be installed on a reinforced concrete base, a layer of asphalt 1 in (2.5 cm) thick must be placed on the concrete base prior to laying out the heating cables.

Review and understand the technical requirements in Section 2 prior to installing the heating cables.



**Important:** Ensure that the sub-base has been properly prepared (see Section 2.2). Concrete and asphalt installations must be designed to accommodate the expected load and environmental conditions and provide long term structural stability.

1. **Asphalt base:** Place the asphalt base course and allow to set. The depth of the asphalt base course and the grade of asphalt used must be designed to handle the expected load and environmental conditions and to provide long-term structural stability.

**Concrete base:** Clean the concrete base slab. The surface of the base slab must be properly cleaned and prepared to allow the asphalt to bond to the base slab. Use an appropriate method for proper bonding or consult with the structural engineer. Next, place a layer of asphalt 1 in (2.5 cm) thick over the well cleaned concrete base prior to laying out the cables (see Figure 17). Do not install the heating cables directly on the concrete base.

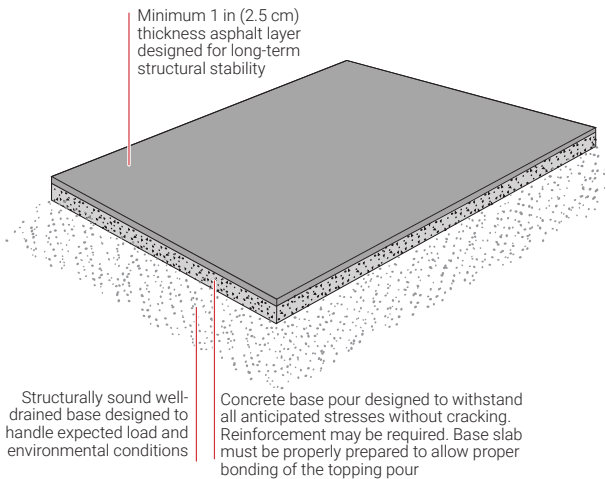

Figure 17: Asphalt installation with concrete base

2. Asphalt installations do not require expansion joints. However, isolation joint material should be placed where the slab will abut other structures, such as building walls.
3. Install the junction boxes. For single conductor cables, the cable layout should begin and end at or close to the junction box to allow the cold leads to be fed back to the junction box. Section 4 shows several typical installation methods for junction boxes.
4. Install prepunched strapping at 3 to 4 ft (0.9 to 1.2 m) intervals, with additional runs where required, to hold cable loops securely (see Figure 18). Anchor the strapping to the asphalt base using an appropriate fastening method.
5. Lay out the heating cable in a serpentine pattern and fasten the cable to the prepunched strapping, at the predetermined spacing, ensuring the watt density is as specified in the design requirements (see Section 2.10). It is recommended that the tabs on the prepunched strapping be bent backwards over the cable as shown in Figure 12 as the sharp edges can cut into the jacket when the hot asphalt is placed. Typical cable spacing ranges between 3 in (7.5 cm) minimum to 6 in (15 cm) maximum on centers. For sloping ramps, such as a ramp to an underground parking garage, serpentine the cables across the width of the ramp to improve snow melting effectiveness. Stay at least 6 in (15 cm) from edges and outer walls (see Figure 18 for details).



**Important:** The heating cable spacing may have to be adjusted to ensure uniform coverage over the area to be heated.

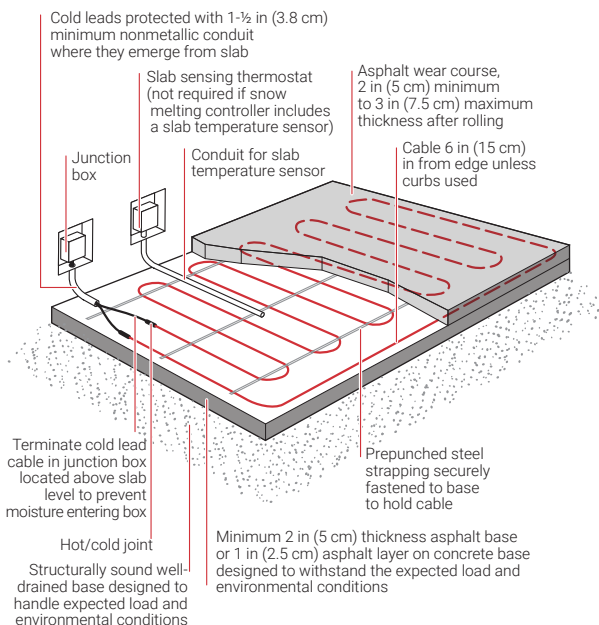

Figure 18: Asphalt installation

6. Install hot/cold joints so that they are at least 6 in (15 cm) in from the edge of the paved area, ensuring that they will be completely embedded in the asphalt (see Section 2.6). Protect the cold leads with nonmetallic conduit where they emerge from the asphalt (see Figure 18 and Section 4 for details).
7. Install the conduit for the slab temperature sensor (see Section 2.11 for details).



**Important:** Do not install the temperature sensor at this time.

8. Visually inspect the heating cables, cold leads, and junction boxes (see Section 2.14) and record the results in the Surface Snow Melting Installation Record in Section 10.
9. Before the asphalt is placed, check the insulation resistance of all heating cables to verify that the cables were not damaged during installation. Details on testing can be found in Section 8. Minimum acceptable IR is 20 MΩ at 1000 Vdc. Record the results of the tests in the Surface Snow Melting Installation Record in Section 10.
10. Place a layer of asphalt at least ½ in (1.3 cm) thick over the cables by hand, and roll with a roller of approximately 1-½ ton size. This will protect the heating cables from damage by tools or paving equipment during placement of the wear course. Continuously check the insulation resistance of the heating cables to verify that the cables are not damaged during placement of the asphalt – minimum acceptable IR is 20 MΩ at 1000 Vdc.



**Important:** Do not dump the asphalt in a pile over a small area of cables and spread out. The LSZH jacket may be damaged from the concentrated heat of the asphalt. Take precautions to protect the heating cable during the asphalt placement.

Do not use sharp tools such as rakes, shovels, etc. that might damage the heating cable. Do not strike the heating cable with tools, walk on the heating cable, or do anything else that will damage the heating cable.



**Important:** If a cable is damaged during placement of the asphalt, the insulation resistance will immediately decrease. The asphalt placement should be stopped and a small wooden box built around the damaged section. Placement can then continue and repairs made after the asphalt sets up.

11. Place the wear course. The wear course, including the ½ in (1.3 cm) of asphalt placed by hand, must be at least 2 in (5 cm) thick after rolling and must not exceed 3 in (7.5 cm). The wear course must be of a grade of asphalt designed to handle the expected load and environmental conditions. If the wear course is machine laid, use pneumatic tired equipment only.
12. Do not energize the heating cables during the asphalt cooling period. Do not allow traffic on the new completed surface until adequate stability has been attained and the material has cooled sufficiently (refer to contract documents).
13. Ensure drainage will be adequate for run-off of melted snow and ice.
14. Connect the cold leads to the junction box.
15. The slab temperature sensor can be installed at any time after placement of the asphalt wear course. Refer to Section 4 for details.

### 3.3 Heating Cables Installed in Mastic Asphalt

The instructions following show how to install MI surface snow melting heating cables on a new or existing concrete base with a mastic asphalt topping. Review and understand the technical requirements in Section 2 prior to installing the heating cables.



**Important:** Ensure that the sub-base has been properly prepared (see Section 2.2). Concrete and asphalt installations must be designed to accommodate the expected load and environmental conditions and provide long term structural stability.

1. Clean the concrete base slab. The surface of the base slab must be properly cleaned and prepared to allow the mastic asphalt to bond to the base slab. Use an appropriate method for proper bonding or consult with the structural engineer.



**Important:** Mastic asphalt installations do not require expansion joints. However, isolation joint material should be placed where the slab will abut other structures, such as building walls.



**Important:** If using a waterproofing membrane, such as for elevated ramps, prepare the base slab following the details provided in the contract documents.

2. Install the junction boxes. For single conductor cables, the cable layout should begin and end at or close to the junction box to allow the cold leads to be fed back to the junction box. Section 4 shows several typical installation methods for junction boxes.

For a long-lasting ramp, ensure that the mastic asphalt ramp is installed as shown in the cross-section in Figure 19. Place a  $\frac{3}{8}$  in (1 cm) thick base coat of hot mastic asphalt and allow to set.

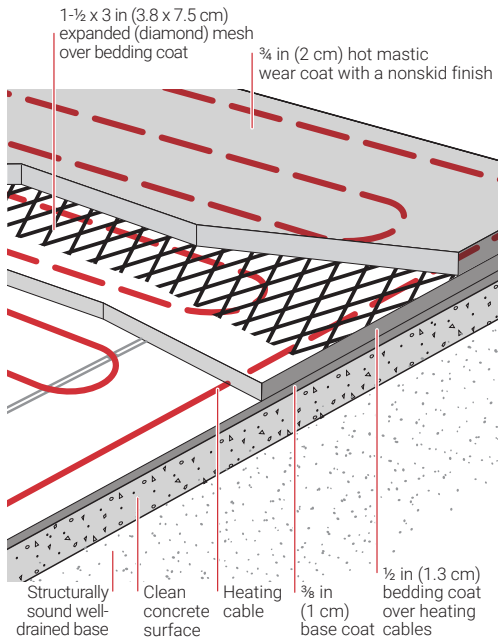

Figure 19: Cross-section showing layers in mastic asphalt ramp

3. Install prepunched strapping at 3 to 4 ft (0.9 to 1.2 m) intervals, with additional runs where required, to hold cable loops securely (see Figure 20). Anchor the strapping to the asphalt base using an appropriate fastening method.
4. Lay out the heating cable in a serpentine pattern and fasten the cable to the prepunched strapping, at the predetermined spacing, ensuring the watt density is as specified in the design requirements (see Section 2.10).

It is recommended that the tabs on the prepunched strapping be bent backwards over the cable as shown in Figure 12 as the sharp edges can cut into the jacket when the hot mastic asphalt is placed. Typical cable spacing ranges between 3 in (7.5 cm) minimum to 6 in (15 cm) maximum on centers. For sloping ramps, such as a ramp to an underground parking garage, serpentine the cables across the width of the ramp to improve snow melting effectiveness. Stay at least 6 in (15 cm) from edges and outer walls (see Figure 20 for details).



**Important:** The heating cable spacing may have to be adjusted to ensure uniform coverage over the area to be heated.

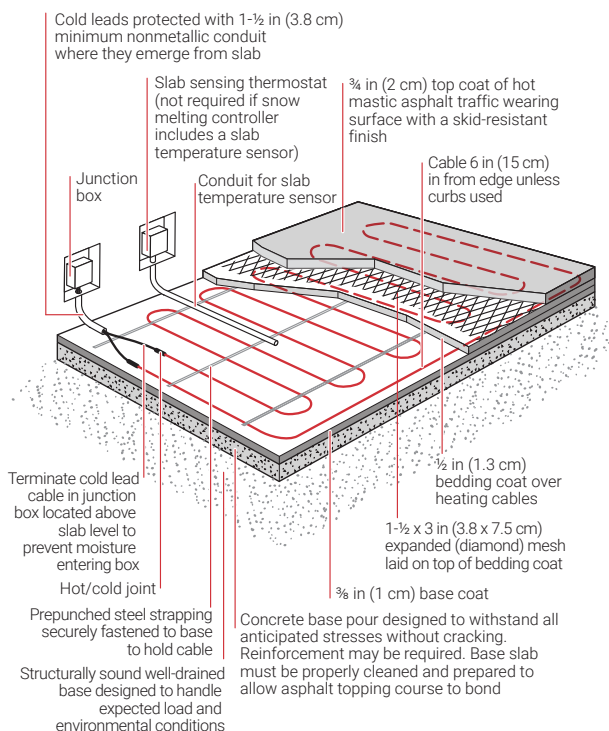

Figure 20: Mastic asphalt with concrete base

5. Install hot/cold joints so that they are at least 6 in (15 cm) in from the edge of the paved area, ensuring that they will be completely embedded in the asphalt (see Section 2.6). Protect the cold leads with nonmetallic conduit where they emerge from the asphalt (see Figure 20 and Section 4 for details).
6. Install the conduit for the slab temperature sensor (see Section 2.11 for details).



**Important:** Do not install the temperature sensor at this time.

7. Visually inspect the heating cables, cold leads, and junction boxes (see Section 2.14) and record the results in the Surface Snow Melting Installation Record in Section 10.
8. Before the mastic asphalt is placed, check the insulation resistance of all heating cables to verify that the cables were not damaged during installation. Details on testing can be found in Section 8. Minimum acceptable IR is 20 M $\Omega$  at 1000 Vdc. Record the results of the tests in the Surface Snow Melting Installation Record in Section 10.
9. Place a ½ in (1.3 cm) thick bedding course of mastic asphalt over the heating cables being careful not to damage the cables. Continuously check the insulation resistance of the heating cables to verify that the cables are not damaged during placement of the mastic asphalt – minimum acceptable IR is 20 M $\Omega$  at 1000 Vdc.



**Important:** Do not dump the mastic asphalt in a pile over a small area of cables and spread out. The LSZH jacket may be damaged from the concentrated heat of the asphalt. Take precautions to protect the heating cable during the asphalt placement. Do not use sharp tools such as rakes, shovels, etc. that might damage the heating cable. Do not strike the heating cable with tools, walk on the heating cable, or do anything else that will damage the heating cable.



**Important:** If a cable is damaged during placement of the mastic asphalt, the insulation resistance will immediately decrease. The asphalt placement should be stopped and a small wooden box built around the damaged section. Placement can then continue and repairs made after the asphalt sets up.

10. Place 8 ft x 4 ft (2.44 m x 1.22 m) sheets of expanded (diamond) mesh over the entire surface, ensuring that the edges overlap by 3 in (7.5 cm); edges of sheets must not just butt against each other.
11. Apply a ¾ in (2 cm) thick wear course of hot process mastic asphalt and finish to produce a skid-resistant surface.
12. Do not energize the heating cables during the mastic asphalt cooling period. Do not allow traffic on the new completed surface until adequate stability has been attained and the material has cooled sufficiently (refer to contract documents).
13. Ensure drainage will be adequate for run-off of melted snow and ice.
14. Connect the cold leads to the junction box.
15. The slab temperature sensor can be installed at any time after placement of the mastic asphalt wear course. Refer to Section 4 for details.

### 3.4 Heating Cables Installed Under Brick and Concrete Pavers

The instructions following show how to install MI snow melting heating cables in brick and concrete paver applications. Review and understand the technical requirements in Section 2 prior to installing the heating cables.

**Important:** Ensure that the sub-base has been properly prepared (see Section 2.2). The sub base must be designed to accommodate the expected load and environmental conditions and provide long term structural stability.

1. Place edge restraints along all unrestrained paver edges. Ensure base is dry, uniform, even, and ready to support limestone screenings or sand, pavers, and imposed loads.
2. Install the junction boxes. For single conductor cables, the cable layout should begin and end at or close to the junction box to allow the cold leads to be fed back to the junction box. Section 4 shows several typical installation methods for junction boxes.
3. Loosely place limestone screening or sand to an uncompacted uniform depth of 1-½ in (3.8 cm) leveled to the grade and profile required (see Figure 21).

**Important:** Do not use sand for sloping areas since the sand will be washed away resulting in damage to the heating cables.

4. Thoroughly compact this base layer. In general, 1-½ in (3.8 cm) uncompacted depth will reduce to 1 in (2.5 cm) after compaction.

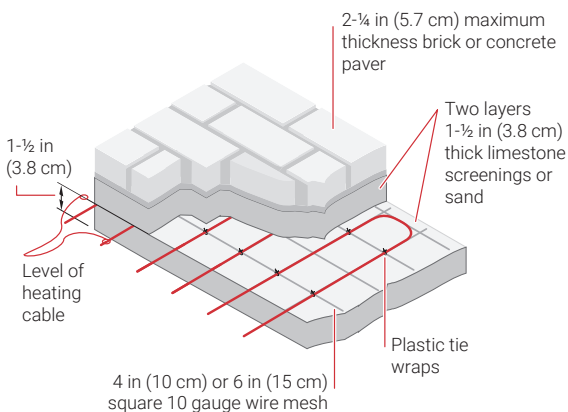

Figure 21: Cross-section showing material layers for paver area

5. Install 4 in (10 cm) or 6 in (15 cm) square 10 gauge wire mesh over the compacted limestone screenings/sand (see Figure 21).

6. Lay out the heating cable in a serpentine pattern on top of the wire mesh and fasten the cable to the mesh with plastic tie wraps (do not use wire), at the predetermined spacing, ensuring that the watt density is as specified in the design requirements (see Section 2.10). Typical cable spacing ranges between 3 in (7.5 cm) minimum to 6 in (15 cm) maximum on centers. For sloping ramps, such as a ramp to an underground parking garage, serpentine the cables across the width of the ramp to improve snow melting effectiveness. Stay at least 6 in (15 cm) from edges and outer walls (see Figure 22).

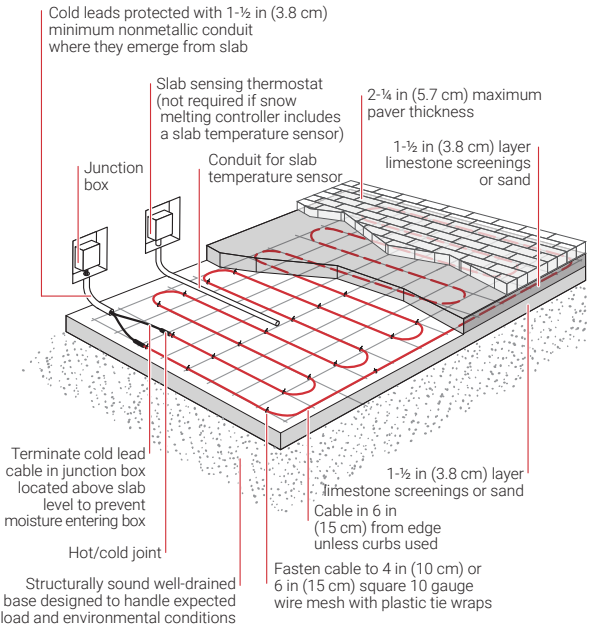

Figure 22: Brick and concrete pavers

7. Install the hot/cold joints so that they are at least 6 in (15 cm) in from the edge of the heated area, ensuring that they will be completely embedded in the limestone screenings or sand (see Section 2.6). Protect the cold leads with nonmetallic conduit where they emerge from the heated area (see Figure 22 and Section 4 for details).
8. Install the conduit for the slab temperature sensor (see Section 2.11 for details).



**Important:** Do not install the temperature sensor at this time.

9. Visually inspect the heating cables, cold leads, and junction boxes (see Section 2.14) and record the results in the Surface Snow Melting Installation Record in Section 10.

10. Before the cables are covered, check the insulation resistance of all heating cables to verify that the cables were not damaged during installation. Details on testing can be found in Section 8. Minimum acceptable IR is 20 MΩ at 1000 Vdc. Record the results of the tests in the Surface Snow Melting Installation Record in Section 10.
11. Loosely place limestone screenings or sand over the heating cable to an uncompacted uniform depth of 1-½ in (3.8 cm) leveled to the grade and profile required. Continuously check the insulation resistance of the heating cables to verify that the cables are not damaged during placement of the limestone screenings or sand – minimum acceptable IR is 20 MΩ at 1000Vdc.



**Important:** Do not use sand for sloping areas since the sand will be washed away resulting in damage to the heating cables.



**Important:** Take precautions to protect the heating cable during the placement of the limestone screenings or sand. Do not use sharp tools such as rakes, shovels, etc. that might damage the heating cable. Do not strike the heating cable with tools, walk on the heating cable, or do anything else that will damage the heating cable.



**Important:** If a cable is damaged during the installation, the insulation resistance will immediately decrease. Mark the location of the damaged section and repair the cable before installing the pavers.

12. Install 2-¼ in (5.7 cm) maximum thickness paving stones and tamp in accordance with the paver manufacturer's recommendations.



**Important:** Take care not to drop the pavers onto the cable or bedding course during installation as the heating cable could be severed by a sharp edge. If a paver is dropped, the cable should be immediately tested for continuity and insulation resistance.

13. Ensure drainage will be adequate for run-off of melted snow and ice.
14. Connect the cold leads to the junction box.
15. The slab temperature sensor can be installed at any time after the installation has been completed. Refer to Section 4 for details.

### 3.5 Concrete and Asphalt Wheel Tracks

The instructions following show how to install MI snow melting cables for concrete and asphalt wheel tracks in residential applications. Review and understand the technical requirements in Section 2 prior to installing the heating cables.



**Important:** Ensure that the sub-base has been properly prepared (see Section 2.2). The sub base must be designed to accommodate the expected load and environmental conditions and provide long term structural stability.

Designing a snow melting or anti-icing system for only the wheel tracks will reduce the power consumption for concrete and asphalt driveways. For residential driveways, two 18 in (46 cm) wide tracks are typically snow melted using four runs of heating cable in each track (see Figure 23). Typical distance between tracks is 6 ft 6 in (2 m), but must be adjusted for the particular vehicle. Excess heating cable may be used up at either end of the driveway.



**Important:** Installation of surface snow melting or anti-icing systems must be done only for concrete or asphalt surfaced driveways. Do not use for brick paver driveways.



**Important:** Due to wider tires used on commercial vehicles, wheel tracks intended for larger vehicles should be minimum 24 in (61 cm) wide. Use six or more runs of heating cable for these wheel tracks.

Verify that the spacing between runs of cable is correct to ensure that the required watt density will be supplied. For an 18 in (46 cm) wide track, cable spacing is approximately 5 in (12.5 cm) but will vary depending on the heating cable wattage and length. If the heating cable was selected from the Surface Snow Melting MI Design Guide (H57045), space the heating cable as recommended in the appropriate table from the design guide. This Design Guide is available on our web site at [chemelex.com](http://chemelex.com).

Complete the wheel track installation by following the instructions in Section 3.1 for installation in concrete or Section 3.2 for installation in asphalt.



**Important:** In areas where snow does not typically melt in winter, even during thaw cycles, contact Chemelex for assistance to avoid snow build-up between wheel tracks.

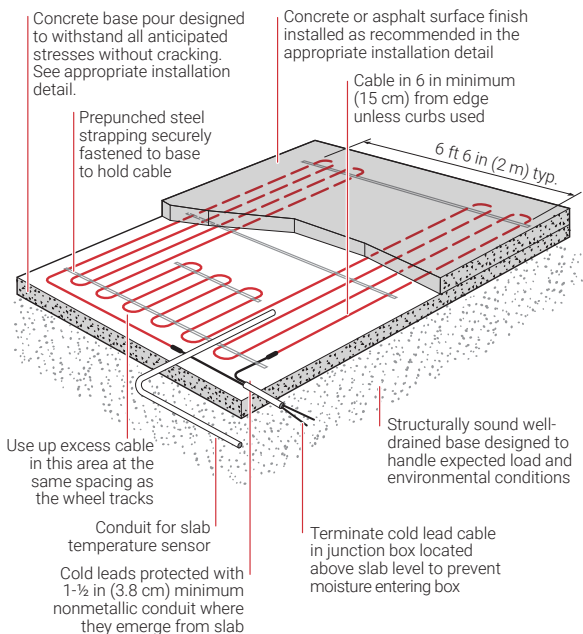

Figure 23: Wheel track installation detail

### 3.6 Concrete Stairs

The instructions following show how to install MI heating cables for concrete stairs. The concrete may be installed using a single pour, where the heating cables are attached to the reinforcement, or two pours, where the cables are attached to a concrete base as shown in Section 3.1. The instructions following show a two-pour installation, but the details for a single-pour installation are similar. Review and understand the technical requirements in Section 2 prior to installing the heating cables.

**Important:** Reinforcement is necessary to ensure that the concrete is structurally sound. Concrete that cracks, crumbles, or settles can damage the heating cable. The reinforcing must be adequately supported so that it is not disturbed by the installation. It is important that the heating cable depth in the concrete be maintained for proper operation of the system.

1. When installing the heating cable on steps with an attached landing, where an expansion joint separates the steps from the landing, do not cross the expansion joint with the heating cable. A separate cable must be installed on the landing.
2. Install the junction boxes. For single conductor cables, the cable layout should begin and end at or close to the junction box to allow the cold leads to be fed back to the junction box. Section 4 shows several typical installation methods for junction boxes.

3. Plan the cable layout on the steps. For a two-pour concrete installation, ensure that the sharp outside corners of the steps are rounded off where the heating cable will cross them (see Figure 24). Mark the locations where rail posts will be installed on the steps. Keep heating cable away from these areas to avoid damaging the cable when the rail post anchors are installed.



**Important:** In two-pour installations it is desirable to make the base slab and topping course truly monolithic since the majority of recorded cable damage is a result of slabs becoming delaminated and shifting. The surface of the base slab must be properly cleaned and prepared to allow the topping pour to bond to the base slab. Use an appropriate method for proper bonding or consult with the structural engineer.

4. Install prepunched strapping at 3 to 4 ft (0.9 to 1.2 m) intervals with additional runs, where required, to hold cable loops securely (see Figure 24). Fasten the strapping in place using an appropriate fastening method.



**Important:** In a single-pour installation, where the heating cable is attached to the reinforcement, ensure that the reinforcement is located at a depth that will allow for 2 in (5 cm) to 3 in (7.5 cm) maximum concrete cover over the heating cable.

5. Lay out the heating cable as shown in Figure 24 and fasten the cable to the prepunched strapping. For concrete steps with a depth of 10.5 to 12 in (27 to 30 cm), three runs of heating cable are typically used, with the first run 2 to 3 in (5 to 7.5 cm) maximum from the front edge, or nose, of the step (this is where snow and ice build-up is the most dangerous) and the remaining two runs spaced equally apart from this run of cable. For steps with a depth of less than 10.5 in (26.7 cm), two runs of cable are typically used with the first run 2 to 3 in (5 to 7.5 cm) maximum from the front edge, or nose, of the step and the second run spaced 5 in (12.5 cm) from this run of cable. Stay at least 4 in (10 cm) from edges, outer walls, and rail post anchor points (see Figure 24).



**Important:** In a single pour installation, layout the heating cable as described above, and fasten the heating cable to the reinforcement with plastic tie wraps (do not use wire).

6. For attached landings, without an expansion joint between the steps, space heating cables 4.5 in (11.5 cm) apart on the landing or as stated in the design specifications.



**Important:** Excess cable may be used up in an attached landing (with no expansion joint between the steps and landing), or by adding an extra run to one or more steps.

7. Install the hot/cold joints so that they are at least 6 in (15 cm) in from the edge of the slab, ensuring that they will be completely embedded in the concrete (see Section 2.6). Protect the cold leads with nonmetallic conduit where they emerge from the slab (see Figure 24 and Section 4 for details).
8. Install the conduit for the slab temperature sensor (see Section 2.11 for details).



**Important:** Do not install the temperature sensor at this time.

9. Visually inspect the heating cables, cold leads, and junction boxes (see Section 2.14) and record the results in the Surface Snow Melting Installation Record in Section 10.
10. Before the concrete is poured, check the insulation resistance of all heating cables to verify that the cables were not damaged during installation. Details on testing can be found in Section 8. Minimum acceptable IR is 20 MΩ at 1000 Vdc. Record the results of the tests in the Surface Snow Melting Installation Record in Section 10.
11. Pour a 2 in (5 cm) minimum to 3 in (7.5 cm) maximum thickness concrete cover over the heating cables and ensure that it is thoroughly consolidated with a high frequency vibrator. Continuously check the insulation resistance of the heating cables to verify that the cables are not damaged during the concrete pour – minimum acceptable IR is 20 MΩ at 1000 Vdc. The concrete cover over the heating cables must be structurally sound and must properly adhere to the base slab to prevent delamination between the slabs.



**Important:** Take precautions to protect the heating cable during the concrete pour. Do not use sharp tools such as rakes, shovels, etc. that might damage the heating cable. Do not strike the heating cable with tools, walk on the heating cable, or do anything else that will damage the heating cable.



**Important:** If a cable is damaged during the concrete pour, the insulation resistance will immediately decrease. The pour should be stopped and a small wooden box built around the damaged section. Pouring can then continue and repairs made after the concrete sets up.

12. Allow the concrete to cure following the specifications in the contract documents.
13. Do not energize the heating cables during the curing period. Do not allow traffic on the new completed surface until adequate stability has been attained and the material has cured sufficiently.
14. Ensure drainage will be adequate for run-off of melted snow and ice.

15. Connect the cold leads to the junction box.
16. The slab temperature sensor can be installed at any time after the concrete installation has been completed. Refer to Section 4 for details.

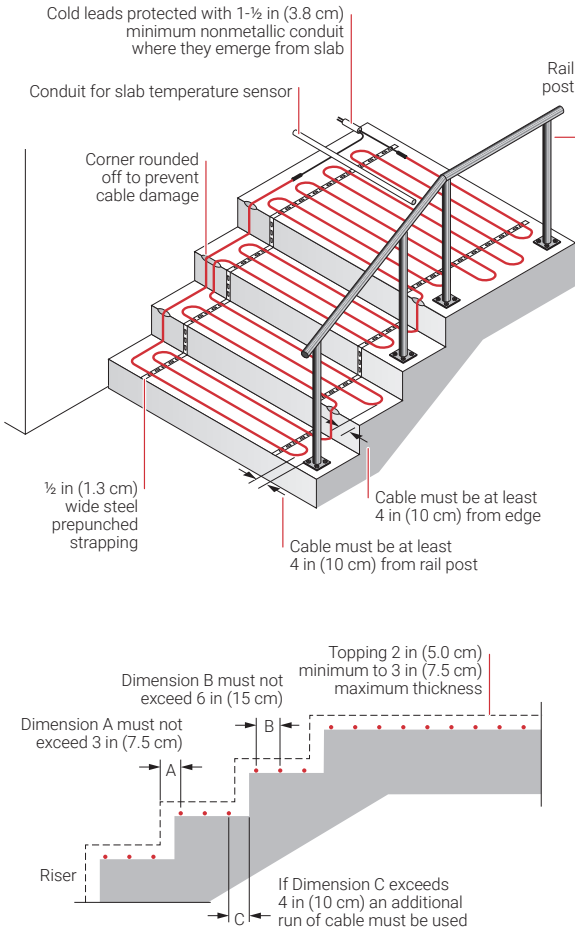



Figure 24: Stair installation detail

## 4. ACCESSORY INSTALLATION

### 4.1 Junction Boxes

The MI heating cables must be connected to UL Listed or CSA Certified junction boxes suitable for the location (UL Listed heating cables must be connected to UL Listed junction boxes). Metallic junction boxes with threaded entries are recommended because the NPT threaded connector (see Table 1 on page 7) provides a ground path for the cable sheath when tightened to the recommended torque. In hazardous areas, the NPT threaded connector also prevents the passage of gases, vapors, liquids and flames.

Nonmetallic junction boxes may be used providing that the NPT threaded connector is grounded using a ground hub as shown in Figure 25. Use a  $\frac{3}{4}$  in NPT ground hub with a  $\frac{1}{2}$  in reducer; this will allow the pot on the end of the cold lead to be fed into the junction box.

 **Important:** Ensure that the heating cable copper sheath is properly grounded. This can be accomplished by connecting the cold lead into a metallic junction box with threaded entries and tightening the gland connector to the recommended torque. When connecting the cables to nonmetallic junction boxes, use ground hubs (see Figure 25) to ensure that the heating cable sheaths will be properly grounded.

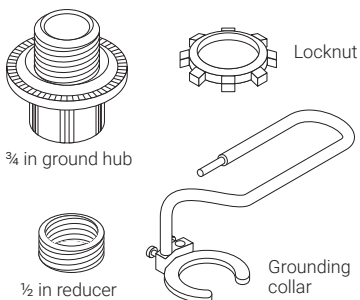

Figure 25: Typical ground hub

### Junction box installation details

Improper location of junction boxes can cause heating cable failure. To avoid problems, the information provided under junction box installation details, handholes, and cold lead installation guidelines should be followed.

- Install the heating cable cold leads and/or conduit leading to the junction box so that water does not enter the box.
- Embedding the junction box in the slab or too low to the ground may allow moisture to enter the junction box, resulting in cable failure; mount junction boxes above grade level, inside the building, or on a structure wall, if possible.

- Do not enter the junction box from the top as this may allow water to enter.
- Take appropriate measures to ensure that moisture does not collect in the bottom of the junction box. Moisture, due to condensation, may form in the box even after the lids have been installed.

Several common methods of installing junction boxes are shown following:

In Figure 26, the junction box is mounted in a recess in the outer wall and protected with a gasketed cover once all electrical connections are completed. In Figure 27, the junction box is mounted on an inside wall. In both cases, the cold leads are fed through flexible nonmetallic conduit, allowing them to flex when the slab expands and contracts. Seal the end of the conduit in the slab to prevent concrete or asphalt from entering the conduit.

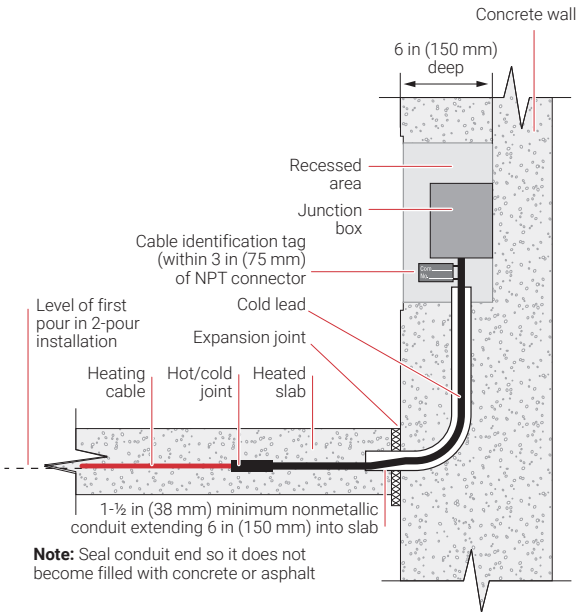

Figure 26: Junction box recessed in wall

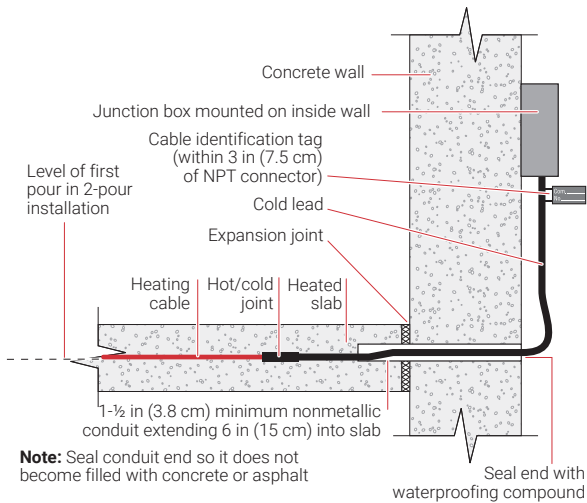

Figure 27: Junction box mounted on inside wall

In Figure 28, the junction box is mounted on the underside of a structural slab above the point where the cold leads enter the base slab. This prevents moisture from tracking along the cold leads and into the junction box.

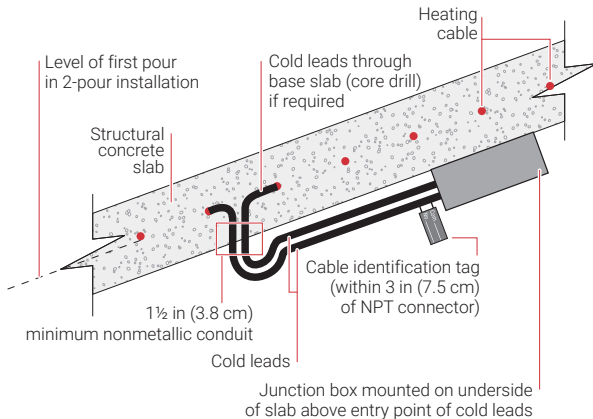

Figure 28: Junction box mounted on underside of structural slab

When connecting the NPT gland connector directly into a metal junction box with threaded entries (Figure 29), insert the tails and tighten the threads on the connector into the junction box (if required, screw a reducer into the threaded entry). For nonmetallic junction boxes, the gland connectors must be threaded into ground hubs (Figure 30).

Install the cold lead “pot” so that it extends about 2 in (5 cm) above the bottom of the junction box (see Figure 29 and Figure 30). Tighten the compression nut on to the cold lead to the torque setting indicated on the tag attached to the gland connector. This ensures that the cable sheath is properly

grounded and prevents the passage of gases, vapors, liquids, and flames in hazardous areas.

In cases where the cold leads are run exposed on exterior walls, prevent damage from vehicles and vandalism by protecting them with a metal guard. Excess cold lead can be embedded directly in the slab or coiled into a 12 in (30 cm) or larger diameter loop and attached to a support close to the junction box.

Connect the heating cable tails and distribution power wires to the terminal block (see typical junction box wiring diagrams in Section 6). Install the junction box lid and make sure it is watertight. Check to make sure that unused entries in the junction box are sealed with hole plugs.

 **Important:** Minimize handling the tails to avoid breakage.

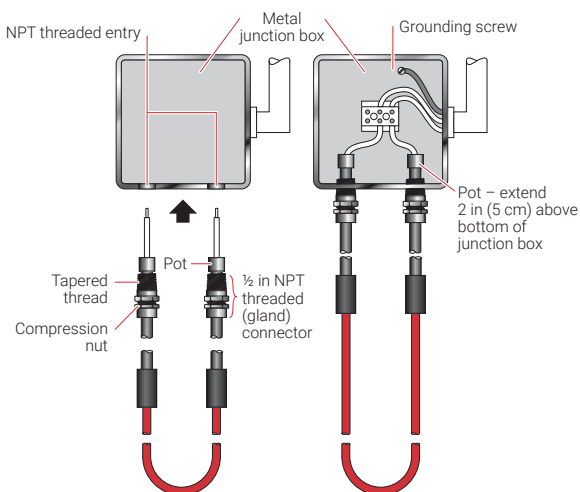

Figure 29: Metal junction box with threaded entries (Design B cable shown)

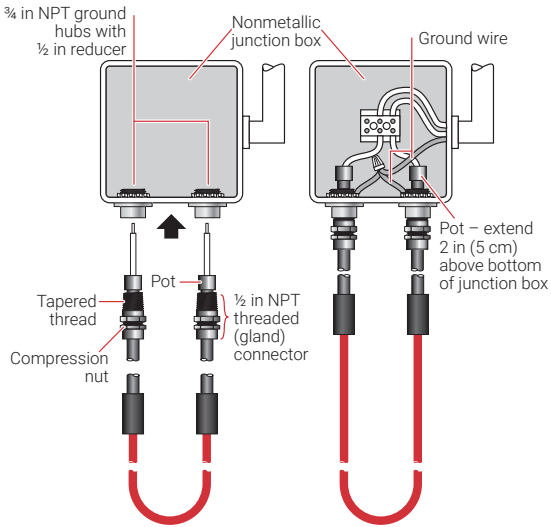

Figure 30: Nonmetallic junction box with ground hubs (Design B cable shown)

In Figure 31, six cold leads (from three Design B/SUB heating cables), to be connected in a three-phase Delta configuration, enter the nonmetallic junction box through the large conduit. The conduit may be run underground from the base slab to the junction box as shown in Figure 34. The power supply conductors and the ground conductor enter through the other conduit.

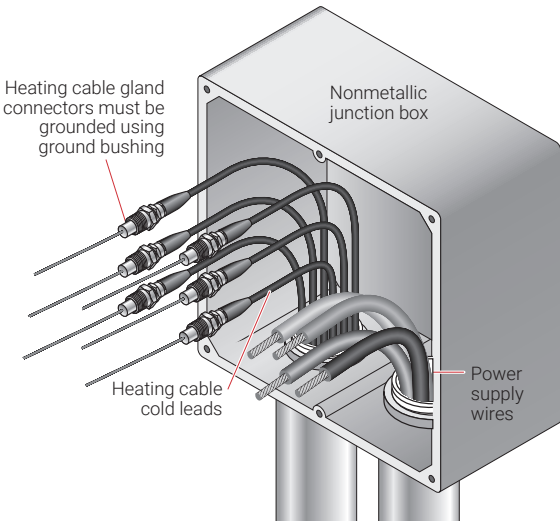

Figure 31: Nonmetallic junction box mounted on wall

When entering a nonmetallic junction box as shown in Figure 31, the copper sheaths of the heating cables must be grounded by: 1) tightening the gland connectors on to the cable sheaths to the recommended torque, and 2) screwing a ground bushing on to each gland connector (Figure 32) and ensuring that the ground wire from each ground bushing is properly bonded to ground per national and local electrical codes.

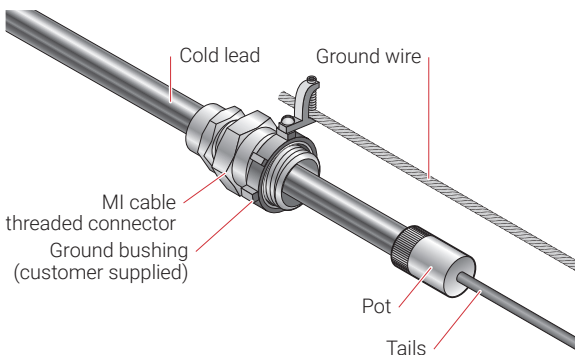



Figure 32: Using ground bushing to ground heating cable sheath

## Handholes

As an alternative to junction boxes, the heating cables may also be terminated in handhole enclosures as shown in Figure 33. Chemelex recommends that handhole enclosures be installed only in areas that will experience pedestrian traffic, such as sidewalks, and grassy areas. Do not install handhole enclosures in areas where vehicular or other heavy traffic may be encountered. The rating of the handhole enclosures should be selected based on the manufacturer's recommendations for the location and the load likely to be imposed on them. Ensure that drainage is in accordance with the manufacturer's instructions.

Keep all power connections as high up in the handhole enclosure as possible. Excess cold lead can be coiled into a loop inside the handhole enclosure. Protect all electrical power connections from moisture by encapsulating the connections with gel filled splice kits such as TE Connectivity Gel Tap Splice (GTAP) gel filled splice kits or equivalent. Ground all heating cable cold leads; where a heating cable has two cold leads, such as Design B (SUB) cable, ensure both ends are grounded.

 **Important:** Ensure that all heating cables are properly grounded. This can be accomplished by tightening the gland connectors on to the cable sheaths to the recommended torque, and then screwing a ground bushing on to each gland connector (see Figure 32). Ensure that the ground wire from each gland connector is properly bonded to ground per national and local electrical codes.

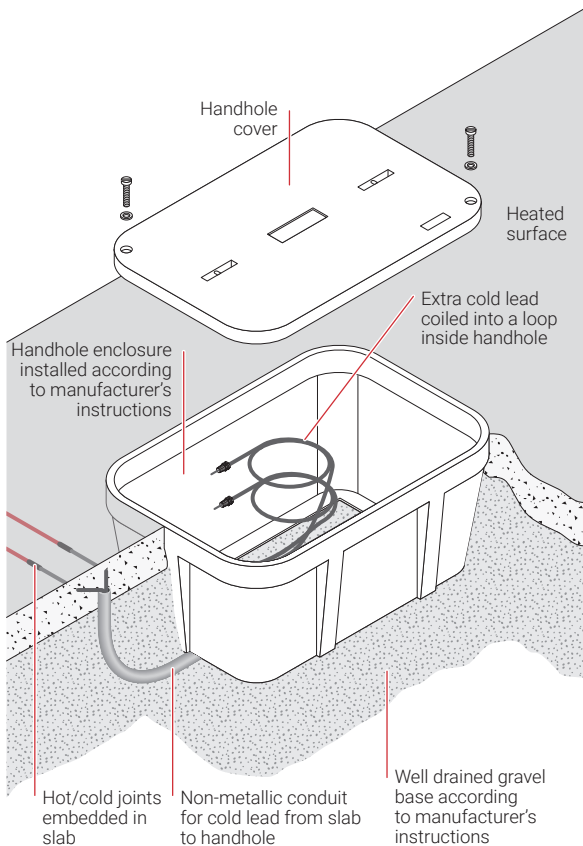

Figure 33: Handhole enclosure mounted in concrete slab

## Cold lead installation guidelines

If possible, plan the location of the junction box so that the cold leads can reach the box without crossing expansion joints. If this is not possible, cross expansion joints between the slab and the building using nonmetallic conduit as shown in Figure 26 and Figure 27. If the cold leads must cross an expansion joint between two heated slabs, use the method shown in Section 2, Figure 10.

In many cases, it may be desirable to run the cold leads through buried conduit directly to the junction box as shown in Figure 34. The cold leads can then be terminated in a nonmetallic junction box as shown in Figure 31 and the heating cable sheaths grounded as shown in Figure 32.

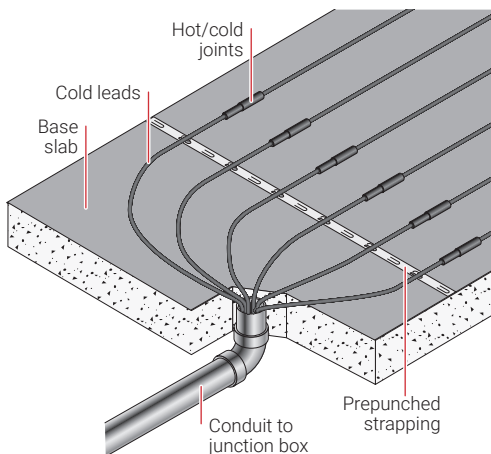

Figure 34: Typical cold lead installation

**Important:** It is recommended that the cold leads be fed through nonmetallic conduit. If using metallic conduit, ensure that both cold leads on single conductor cables are fed through the same conduit.

**Important:** Do not feed more than six single conductor cold leads (from three heating cables), or three two-conductor cold leads through the same conduit.

## 4.2 Slab Thermostat Installation

If using a slab sensing thermostat, mount the enclosure on a wall (Figure 35) close to the conduit which was installed during the heating cable installation (Section 3). Insert the sensor into the conduit far enough out into the area being heated so that it will sense the temperature at approximately the middle of the area. Set the temperature to 50°F (10°C).

- Mount thermostat above grade level and in an area where it will not be damaged by vehicles or vandalism.
- Cable or conduit leading to thermostat must be installed so that water does not enter the enclosure.
- Make sure lid is watertight.

**Important:** The thermostat enclosure must be suitable for the area classification (weatherproof, hazardous area, etc.).

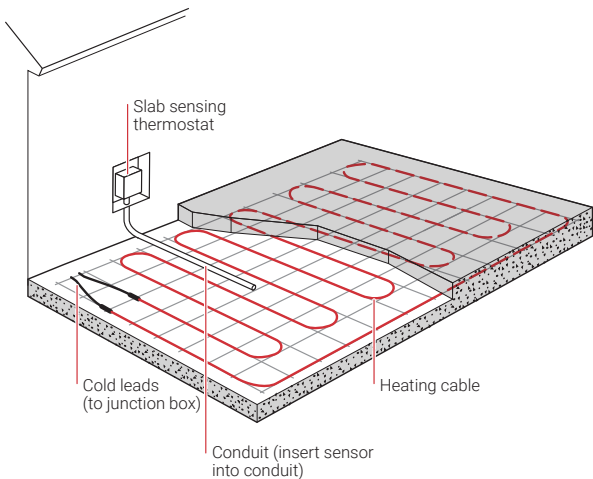

Figure 35: Slab sensing thermostat installation

### Slab Temperature Sensor Installation

For Surface Snow Melting System installations where the slab temperature sensor is integral to the snow melting control panel or automatic snow melting controller, insert the slab temperature sensor into the conduit that was installed during the cable installation. The sensor should be far enough out into the area being heated so that it will sense the temperature at approximately the middle of the area. Set the temperature to 50°F (10°C).

## 5. CONTROL, MONITORING AND POWER DISTRIBUTION

---

The Surface Snow Melting System may be controlled using one of the following three options, but the automatic snow controller offers the highest system reliability and the lowest operating cost.

- Manual on/off control
- Slab sensing thermostat
- Automatic snow controller

If the current rating of the control means is exceeded, all three methods will require contactors sized to carry the load. Each method offers a tradeoff balancing initial cost versus energy efficiency and ability to provide effective surface snow melting. If the system is not energized when required, snow will accumulate. If the system is energized when it is not needed, there will be unnecessary power consumption. For additional information refer to Section 6, or contact your Chemelex representative for details.

### 5.1 Manual On/Off Control

The power contactor or the circuit breakers are manually operated. Manual control is recommended only for small areas.

### 5.2 Slab Sensing Thermostat

This control method energizes the system whenever the slab temperature is below freezing, but is not very energy efficient when used as the sole means of control. It is recommended for all installations, even when an automatic snow controller (without a slab temperature sensor) is used. For asphalt installations, it prevents the surface from softening due to overheating.

### 5.3 Automatic Snow Controller

This control method, Figure 36, automatically energizes the heating cables when precipitation and low temperature are detected. The integral slab temperature sensor de-energizes the heating cables after the slab reaches the controller set-point, even if freezing precipitation is still present. A built-in timer keeps the system energized for a set hold-on time to allow the slab to completely dry once precipitation stops. This is the most energy efficient control solution.

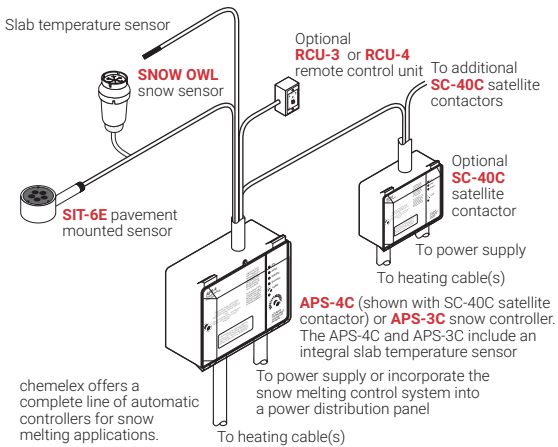

Figure 36: Automatic snow melting control system

## 6. POWER SUPPLY AND ELECTRICAL PROTECTION

---

### 6.1 Voltage Rating

Check the incoming electrical supply to verify that the voltage to be connected to the heating cable is correct. The heating cable voltage rating is printed on the cable tag. For a Wye connected three-phase system, the heating cable voltage rating printed on the tag will equal the line-to-line supply voltage divided by the square root of 3 ( $V_{L-L}/\sqrt{3}$ ).

### 6.2 Circuit Breaker Sizing

Size circuit breakers according to electrical code requirements. Single-phase connected heating cables require single-pole circuit breakers if one leg of the circuit will be wired to a neutral, otherwise two-pole breakers are required. For three-phase connected heating cables, 3-pole circuit breakers are required. Generally, heating cable current draw, supply voltage, and wiring configuration are required to size circuit breakers. Refer to the heating cable tag for the electrical characteristics of the heating cable.

The minimum breaker size may be determined as follows:

#### Single-Phase Circuit

For a single-phase connected heating cable circuit, the minimum breaker size can be calculated using the following formula:

$$\text{Breaker size} = \text{Heating cable current}^* \times 1.25$$

#### Balanced Three-Phase Circuit

For a Delta connected heating cable circuit, the minimum breaker size can be calculated using the following formula:

$$\text{Breaker size} = \text{Heating cable current}^* \times \sqrt{3} \times 1.25$$

For a Wye connected heating cable circuit, the minimum breaker size can be calculated using the following formula:

$$\text{Breaker size} = \text{Heating cable current}^* \times 1.25$$

\* Heating cable current = Watts/Voltage (see cable ID tag)

### 6.3 Ground-Fault Protection

Use circuit breakers with 30 mA ground-fault protection on all heating cable circuits. If commercially available ground-fault circuit breakers are unavailable for the voltage and current rating of the circuit, ground-fault protection may be accomplished using a shunt trip breaker and ground-fault sensor (see Figure 43 to Figure 46) or using an Raychem SMPG series power distribution and control panel (Figure 47).

Ground-fault equipment protection (GFEP) is required for all electric surface snow melting installations to prevent arcing or fire if the cable is improperly installed or damaged. To minimize the risk of fire, Chemelex and national electrical codes require both ground-fault protection of equipment and a grounded metallic covering on all heating cables.

**⚠ Warning:** To minimize the danger of fire from sustained electrical arcing if the heating cable is damaged or improperly installed, and to comply with Chemelex requirements, agency certifications, and national electrical codes, ground-fault equipment protection must be used on each heating cable branch circuit. Arcing may not be stopped by conventional circuit protection.

**⚠ Warning:** To prevent shock or personal injury, disconnect all power before making connections to the heating cable.

### 6.4 Junction Box Wiring

Typical junction box wiring for a single-phase connected heating cable is shown in Figure 37. Balanced three-phase connected heating cables (cables are the same voltage and wattage) are shown in Figure 38 and Figure 39. In the delta connected circuit shown in Figure 38, the three heating cables are connected to a single junction box, but could be connected to individual junction boxes and three-phase connected at the contactor.

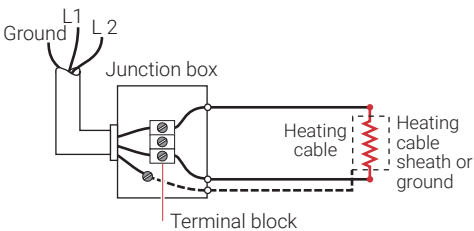

Figure 37: Typical 1Ø connection

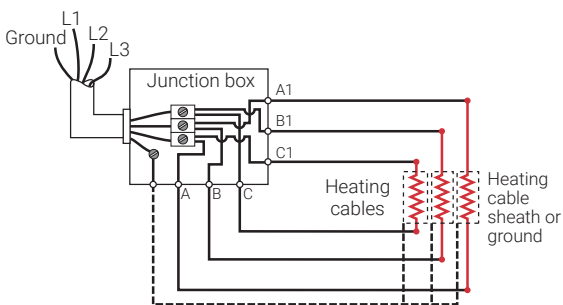

Figure 38: Typical 3Ø Delta connection

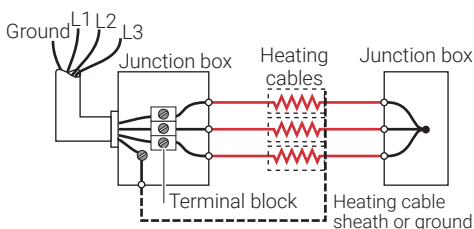

Figure 39: Typical 3Ø Wye connection

## 6.5 Typical Wiring Diagrams

Typical single and three phase wiring diagrams using only a slab temperature sensor are shown in Figure 40 to Figure 44. The wiring diagrams in Figure 45 and Figure 46 show an APS-3C automatic snow melting controller configured to operate balanced three-phase Delta connected heating loads, using external contactors and shunt trip breakers with ground-fault sensors to provide ground-fault equipment protection. Figure 47 shows an SMPG3 automatic snow melting power distribution and control panel with integral ground-fault equipment protection. Follow all requirements of national and local electrical codes when connecting heating cables and controllers.

The APS-4C snow melting controller and SC-40C satellite contactor (not shown) are supplied with a built-in contactor and provide ground-fault equipment protection. The 277 volt single-phase APS-4C and SC-40C can handle loads up to 40 amps maximum and the three-phase models can handle loads up to 50 amps maximum. Detailed wiring diagrams can be found in the manufacturer's instructions supplied with the controllers.

For snow melting installations controlled only by a slab sensing thermostat, use a contactor when switching loads greater than the maximum current or voltage rating of the thermostat.

When connecting heating cables in a three-phase Delta configuration, the heating cable voltage must equal the line-to-line supply voltage; e.g., on a 480 volt, three-phase supply, the heating cable voltage must equal 480 volts. When connecting heating cables in a Wye configuration, the heating cable voltage

must equal the line-to-neutral supply voltage; e.g., on a 480 volt, three-phase supply, the heating cable voltage must equal 277 volts.

For wiring configurations outside the scope of this manual, please contact your Chemelex representative for assistance.

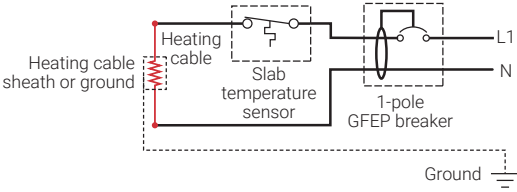

Figure 40: Thermostat control of heating cable on 1Ø line-to-neutral supply

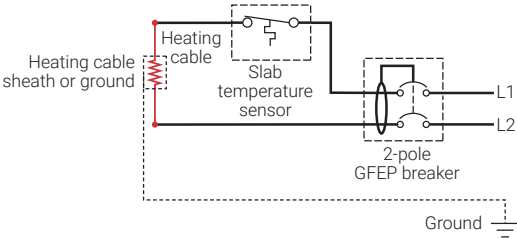

Figure 41: Thermostat control of heating cable on 1Ø line-to-line supply

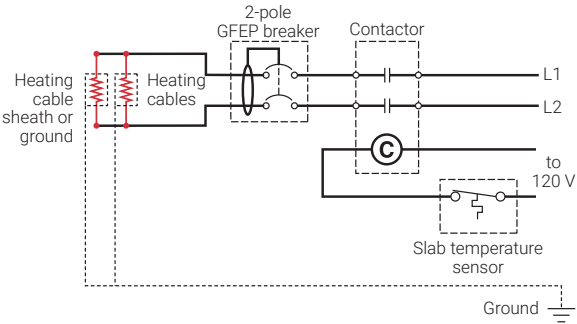

Figure 42: Thermostat control of parallel connected heating cables with contactor on 1Ø line-to-line supply

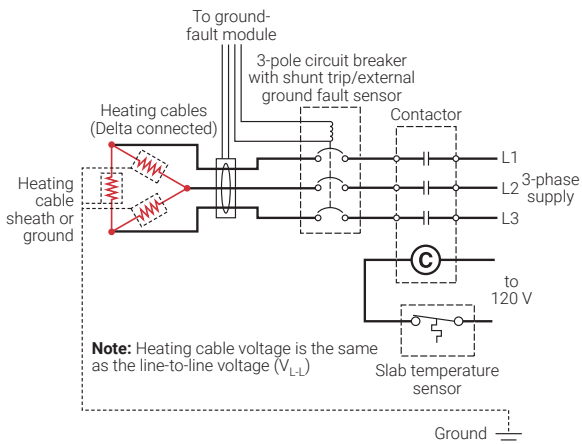

Figure 43: Thermostat control of balanced 3Ø Delta connected heating cables with contactor

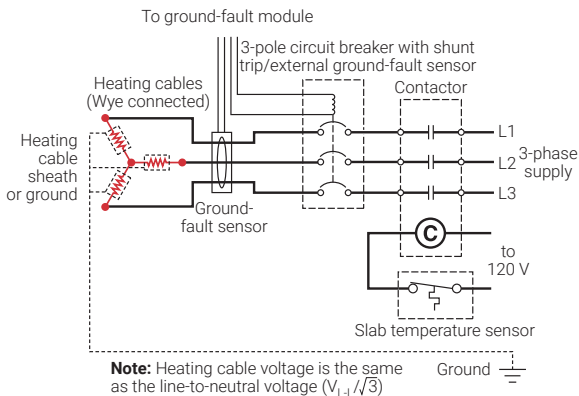

Figure 44: Thermostat control of balanced 3Ø Wye connected heating cables with contactor

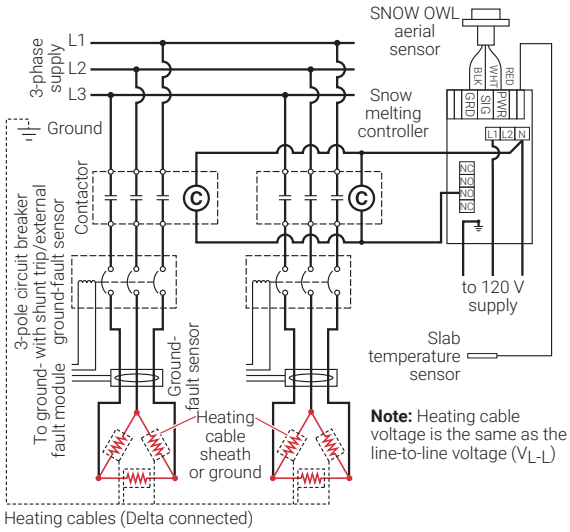

Figure 45: Control of balanced 3Ø Delta connected heating cables with individual contactors and APS-3C automatic snow controller

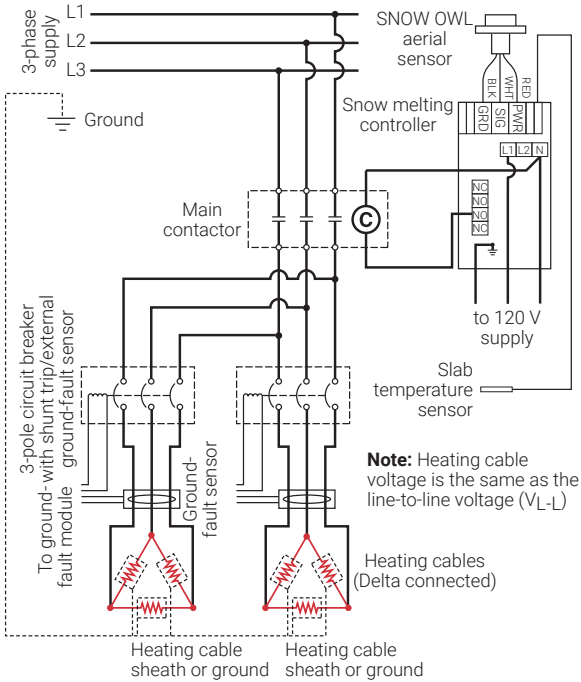

Figure 46: Control of balanced 3Ø Delta connected heating cables with main contactor and APS-3C automatic snow controller

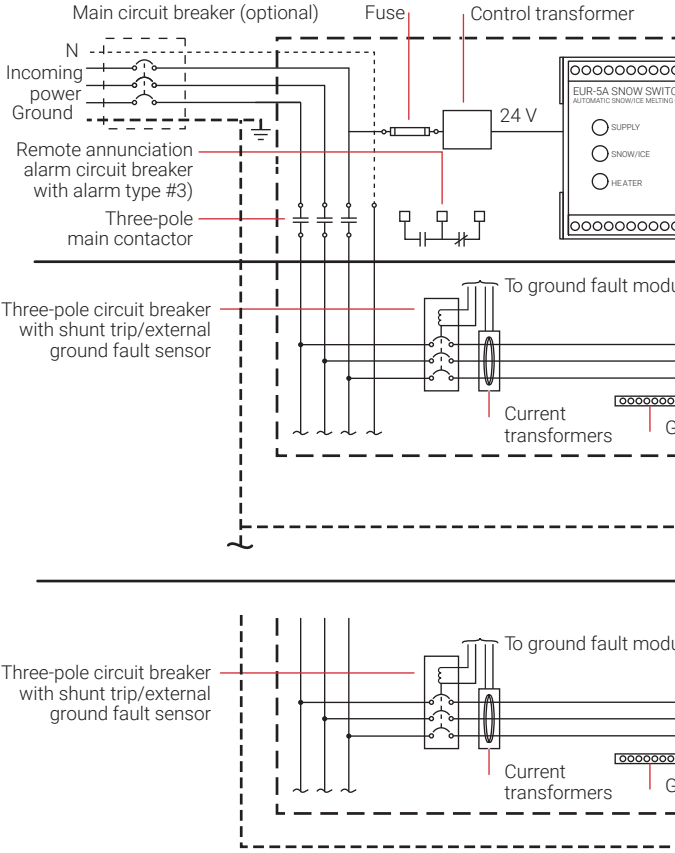
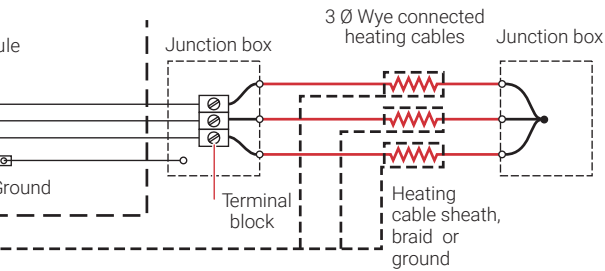
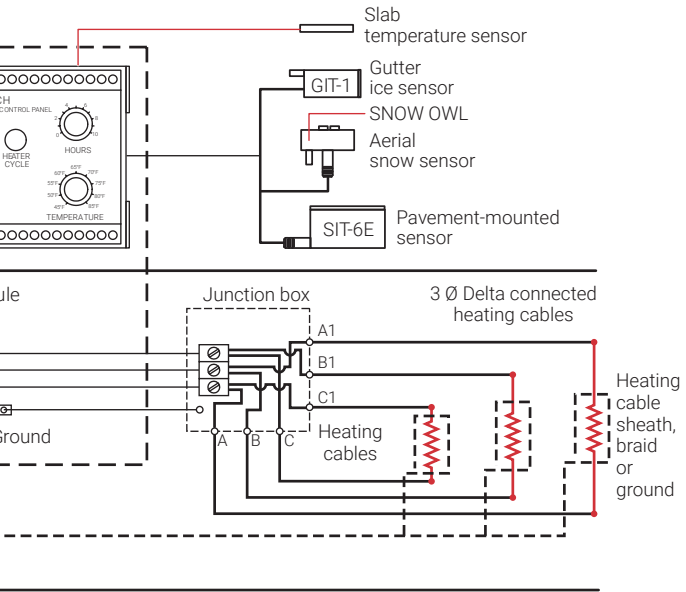

Figure 47: SMPG3 power distribution and control panel



## 7. COMMISSIONING AND PREVENTIVE MAINTENANCE

---

Chemelex requires that a series of commissioning tests be performed on the system. These tests are also recommended annually for preventive maintenance. Results must be recorded and maintained for the life of the system, utilizing the Surface Snow Melting Installation Record (refer to Section 10). Submit this manual with initial commissioning test results to the owner.

### 7.1 System Tests

A brief description of each test is found below. Detailed test procedures are found in Section 8.

#### Visual Inspection

Inspect all wiring for conformance to design drawings and applicable codes. Inspect the junction boxes, cable terminations, and connections to the cable for physical damage. Inspect the cold leads from the point where they exit the slab to the junction boxes for physical damage. Check that moisture is not present in the junction boxes, that electrical connections are tight, and that the NPT threaded connectors are tight and properly grounded.



**Important:** Damaged cold leads and terminations must be repaired or replaced.

#### Continuity and Insulation Resistance

Continuity and insulation resistance (IR) testing is recommended at four stages during the installation process, as part of regular system inspection, and after any maintenance or repair work. Continuity testing checks the integrity of the resistive heating element inside the heating cable. IR testing checks the integrity of the electrical insulating barrier between the resistive heating element and the cable sheath. IR testing can also be used to isolate the damage to a single run of heating cable. Fault location can be used to further locate damage.

#### Snow Melting Controller

Test the functioning of the controller by following the instructions supplied by the manufacturer.

#### Power Check

The power check is used to verify that the system is generating the correct power output. This test can be used in commissioning to confirm that the circuit is functioning correctly. For ongoing maintenance, compare the power output to previous readings.

The heating cable power output (watts) is printed on the identification tag attached to the heating cable. Some SUA/SUB

heating cables (see Surface Snow Melting – MI Design Guide, H57045) have been designed for use on several different supply voltages. The tag shows a corresponding wattage produced for each value of supply voltage (see Figure 1 on page 8).

Energize the circuit breaker and measure the heating cable current using a clamp-on or in-line ammeter. Measure the voltage across the heating cable using a volt meter. Calculate the heating cable wattage using the measured voltage and current.

The calculated wattage can be compared to the wattage indicated on the heating cable tag. This gives a good indication of heating cable performance.

## Ground-Fault Test

Test all ground-fault breakers per manufacturer's instructions.

## 7.2 Preventive Maintenance

Surface Snow Melting Systems may be subject to concrete or asphalt cracking, surface modifications and rework, or electrical maintenance that might affect them. Chemelex recommends performing the commissioning tests before the first use of the system each autumn to detect changes or damage that might affect the operation of the system.

If the system fails any of the tests, refer to Section 9 for troubleshooting assistance. Make the necessary repairs and replace any part of the system if it has been found to be defective. Protect the cold leads from mechanical damage during maintenance work.



**Important:** De-energize all circuits that may be affected during maintenance work.

## Maintenance Records

The Maintenance Log Record (refer to Section 10) should be filled out during all inspections and kept for future reference.

## Repairs

Use only Raychem MI cable and components when replacing any damaged cable. Repairs should be performed only by qualified personnel and to Chemelex requirements. Retest the system after all repairs or replacements.



**Warning:** Damage to cables or components can cause sustained electrical arcing or fire. Do not energize cables that have been damaged. Repair or replace damaged heating cable or terminations before energizing the circuit.

Chemelex recommends that the heating cable Surface Snow Melting Installation Record in Section 10 be completed during testing and kept for future reference.

## 8. TEST PROCEDURES

---

### 8.1 Visual Inspection

- Inspect all wiring for conformance to applicable codes.
- Check circuit breaker sizing for each circuit to make sure it is suitable for the circuit current and voltage.
- Verify that the contactor coil operating voltage is correct for the control device used.
- Verify electrical wiring of automatic snow melting control system. Check for moisture, corrosion, and switch operation and ensure that controller is operational and properly set.
- Verify slab temperature sensor or thermostat sensor is correctly installed, sensor lead or capillary is not damaged, and ensure that slab temperature control or thermostat is operational and set to 50°F (10°C) or as required in the project specifications.
- Visually inspect junction boxes, cold leads, terminations, and electrical connections to the cable for physical damage. Repair or replace damaged cable and terminations.
- Verify that the cable glands are correctly fitted into junction boxes, tight, and properly grounded.
- Check that no moisture is present in junction boxes and that electrical connections are tight.
- Verify that all junction boxes are appropriate for the area classification and properly sealed.

### 8.2 Insulation Resistance Test – Test 1

Insulation resistance is measured between the heating cable sheath and the tails. Chemelex recommends that the insulation resistance test be conducted at, but not exceeding 1000 Vdc, however in the absence of equipment with this capability, a 500 Vdc test is suitable to detect most installation related concerns.

#### Frequency

Insulation resistance testing is recommended at four stages during the installation process and as part of regularly scheduled maintenance.

- When received – minimum 100 MΩ
- After the cables have been installed – minimum 20 MΩ
- Continuously during placement of concrete, asphalt, etc. – minimum 20 MΩ
- Prior to initial start-up (commissioning) – minimum 20 MΩ\*
- As part of the regular system inspection
- After any maintenance or repair work

\* Under adverse weather conditions, or when the tails or terminal connections have evidence of moisture, lower

insulation resistances may be encountered. Wipe tails, face of pot, and all terminal connections with a clean dry rag to eliminate moisture and retest.

## Test Criteria

The minimum insulation resistance for a clean, dry, properly installed heating cable should reflect the values shown above, regardless of the heating cable length.

## 8.3 Continuity (Resistance) Test – Test 2

Continuity testing is conducted using a standard Digital Multimeter (DMM) and measures the resistance between the cold lead tails. This test should also be done after any maintenance or repair work.

## Test Criteria

Measure the resistance of the MI heating cable with the DMM. Most MI heating cable resistances are less than 100 ohms. The approximate resistance can be calculated using the formula: Resistance (ohms) = Volts<sup>2</sup> / Watts. Voltage and wattage are printed on the heating cable identification tag.

## 8.4 Insulation Resistance and Continuity Test Procedure

1. De-energize the circuit.
2. Disconnect the heating cable tails from supply wires or terminal block.
3. Set megohmmeter test voltage to 0 Vdc or off.
4. Connect the positive (+) lead to the heating cable sheath.
5. Connect the negative (-) lead to both heating cable tails simultaneously.



**Important:** In cases where the opposite end of the heating cable does not terminate in the same junction box, it must be disconnected from the power supply or series connected heating cable and kept isolated from surrounding metal objects to avoid erroneous readings.

6. Turn on the megohmmeter and set the voltage to 1000 Vdc; apply the voltage for 1 minute. Meter needle should stop moving. Rapid deflection indicates a short. Record the insulation resistance value in the Surface Snow Melting Installation Record in Section 10.
7. Turn off the megohmmeter.
8. If the megohmmeter does not self-discharge, discharge phase connection to ground with a suitable grounding rod. Disconnect the megohmmeter.
9. Check the continuity (resistance) of the heating cable between the two tails. Record the resistance value in the Surface Snow Melting Installation Record in Section 10.

10. Disconnect the multimeter.
11. Reconnect heating cable tails to the supply wires or terminal block.

If the heating cable fails either the insulation resistance or continuity test, stop and follow the troubleshooting instructions in Section 9.

**Warning:** Fire hazard in hazardous locations. Insulation resistance tests can produce sparks. Be sure there are no flammable vapors in the area before conducting this test.

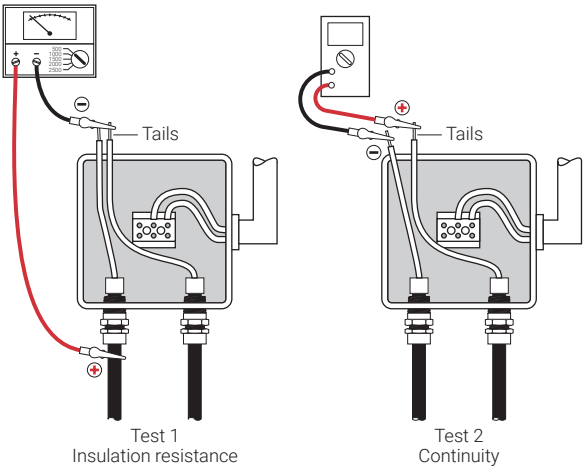

Figure 48: Insulation resistance and continuity test

## 8.5 Power Check

The power for single and three-phase circuits can be calculated as shown below. For clarity, automatic snow controllers, circuit breakers, and junction boxes have been omitted.

### Single-Phase Circuits

Energize the circuit and measure the supply line current using a clamp-on or in-line ammeter; if an in-line ammeter is used, it must be series connected in the circuit (see Figure 49). Measure the voltage across the heating cable using a voltmeter. Record the values in the Surface Snow Melting Installation Record in Section 10. This information is needed for future maintenance and troubleshooting.

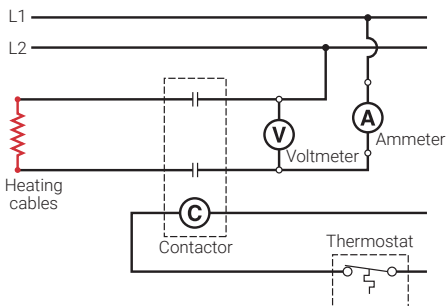

Figure 49: Using voltmeter and ammeter to measure voltage and current in a single-phase circuit

The heating cable power (watts) can be calculated by multiplying the measured voltage (volts) by the measured current (amperes) using the following formula:

$$\text{Power (W)} = \text{Volts (V)} \times \text{Current (A)}$$

Compare the calculated wattage to the wattage printed on the heating cable tag. This gives a good indication of heating cable performance. Variations of 10% to 20% are possible due to deviations in measurement equipment, supply voltage, and cable resistance.

### Balanced Three-Phase Circuits

Energize the circuit and measure the supply line current for each phase of the circuit using a clamp-on or in-line ammeter; if an in-line ammeter is used, it must be series connected in the circuit (see Figure 50). The three current measurements should be approximately equal. Measure the voltage across each line-to-line pair (L1-L2, L2-L3, L1-L3) using a voltmeter. The three voltage measurements should be equal. Record the values in the Surface Snow Melting Installation Record in Section 10. This information is needed for future maintenance and troubleshooting.

**Important:** For a Wye connected three-phase circuit, the voltage (L-N) across each heating cable will equal the line-to-line supply voltage, measured in Figure 50, divided by the square root of 3 ( $V_{L-L}/\sqrt{3}$ ).

### Delta connected circuit

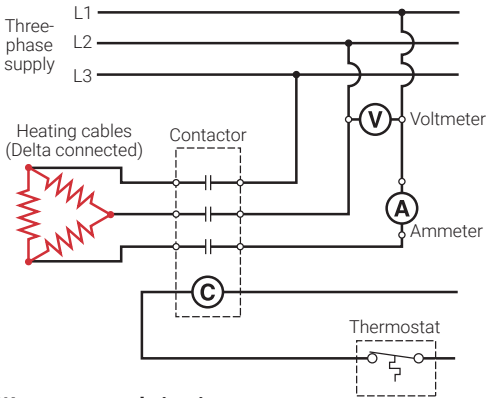

### Wye connected circuit

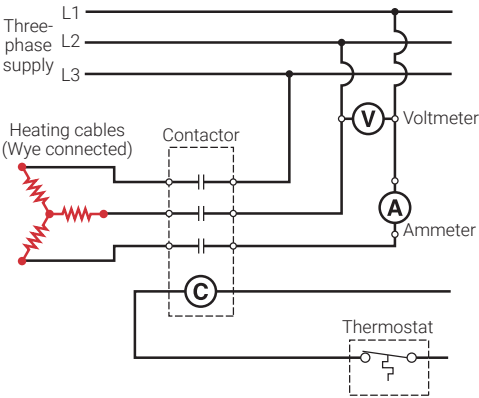

Figure 50: Using voltmeter and ammeter to measure voltage and current in each phase of a three-phase circuit

For balanced Delta and Wye connected three-phase circuits, the heating cable power (watts), for each cable, can be calculated by multiplying the measured voltage by the measured current and dividing this result by the square root of 3 using the following formula:

$$\text{Power/cable (W)} = \frac{\text{Volts (V)} \times \text{Current (A)}}{\sqrt{3}}$$

If the voltage measurement is taken directly across each heating cable in a Wye connected circuit, the power can be calculated simply by multiplying this measured voltage by the measured current using the following formula:

$$\text{Power/cable (W)} = \text{Volts (V)} \times \text{Current (A)}$$

The calculated wattage can be compared to the wattage printed on the heating cable identification tag. This gives a good indication of heating cable performance. Variations of 10% to 20% are possible due to deviations in measurement equipment, supply voltage, and cable resistance.

## **8.6 Fault Location Testing**

MI heating cable is the most rugged heating cable available; however, damage does occur occasionally. Most damage occurs during installation due to bending too sharply, planks thrown on the cable, cutting the cable with shovels, or cutting or drilling through the cable after installation. Using good installation practices and following the "Test Procedures" in the preceding sections will reveal any installation problems and permit faults to be located and repaired prior to commissioning of the system. The distance a fault is located from the end of the cable can usually be pinpointed quite accurately; a heating cable layout drawing will be required to determine exactly where the fault lies. Refer to H58744 Tests to Locate Faults in MI Heating Cable, available on our web site at [chemelex.com](http://chemelex.com).

## 9. TROUBLESHOOTING GUIDE

Symptom	Probable Causes
Insulation resistance less than expected	<ol style="list-style-type: none"><li>1. Rain or high humidity.</li><li>2. Nicks or cuts in heating cable or cold lead sheath, with moisture present.</li><li>3. Kinked or crushed heating cable or cold lead.</li><li>4. Physical damage to heating cable or cold lead is causing a direct short from conductor to sheath.</li><li>5. Presence of moisture in terminations or connections.</li><li>6. Damaged termination.</li></ol>
Resistance lower than expected	<ol style="list-style-type: none"><li>1. Conductor(s) shorted to sheath along length of heating cable.</li><li>2. Both conductors in dual-conductor cable shorted together along length of heating cable.</li></ol>
Resistance is infinite	<ol style="list-style-type: none"><li>1. Conductor is open circuited.</li></ol>
Resistance is zero	<ol style="list-style-type: none"><li>1. Conductor(s) shorted to sheath at termination or hot/cold splice.</li></ol>
Circuit breaker trips	<ol style="list-style-type: none"><li>1. Circuit breaker undersized.</li><li>2. Defective circuit breaker.</li><li>3. Short circuit in electrical connections.</li><li>4. Excessive moisture in connection boxes.</li><li>5. Nicks or cuts in heating cable or cold lead sheath, moisture present.</li><li>6. Kinked or crushed heating cable or cold lead.</li><li>7. GFEP device trip level too low (5 mA used instead of 30 mA) or miswired.</li></ol>

## Corrective Action

- (1) Dry tails and face of seal. Inspect power connection box for moisture or signs of tracking. Dry out connections and retest.
  - (2, 3) Fault locate to find damaged section of cable (see H58744 for details). If damaged, repair or replace heating cable or cold lead.
  - (4) Check for visual indications of damage around any area where there may have been maintenance work. Look for cracked or damaged concrete or asphalt or any evidence of work on the slab surface. Repair or replace damaged sections of heating cable, cold lead or terminations.
  - (5) Dry out cold lead and/or connections and replace termination if necessary.
  - (6) Replace termination.
- 

- (1, 2) Fault locate to find damaged section of cable (see H58744 for details). Repair or replace damaged sections of heating cable.
- 

- (1) Fault locate to find damaged section of cable (see H58744 for details). Repair or replace damaged sections of heating cable, cold lead, or terminations.
- 

- (1) Fault locate to find damaged section of cable (see H58744 for details). Repair or replace damaged hot/cold splice or termination.
- 

- (1) Recalculate circuit load current. Resize breaker and wiring as required.
  - (2) Repair or replace breaker.
  - (3) Locate and repair the incorrect connections.
  - (4) Install drains in connection boxes as required. Dry cold lead and replace terminations if required.
  - (5,6) Fault locate to find damaged section of cable (see H58744 for details). Repair or replace damaged sections of heating cable, cold lead, or terminations.
  - (7) Replace 5 mA GFEP device with 30 mA GFEP device. Check the GFEP wiring instructions.
-

Symptom	Probable Causes
Power output appears correct but snow and ice is slow to melt.	<ol style="list-style-type: none"> <li>1. Slab temperature sensor or slab sensing thermostat set incorrectly.</li> <li>2. Thermal time delay.</li> <li>3. Weather conditions too severe for design.</li> <li>4. Inadequate watt density (W/sq ft; W/sq m).</li> <li>5. Wrong cable installed.</li> </ol>
Power output is zero or incorrect	<ol style="list-style-type: none"> <li>1. Snow melting controller inoperative.</li> <li>2. Slab sensing thermostat inoperative.</li> <li>3. Slab sensing thermostat wired in the normally open (N.O.) position.</li> <li>4. No input voltage.</li> <li>5. Broken or damaged heating cable, cold lead, or hot/cold joint.</li> <li>6. Circuit breakers tripped.</li> <li>7. Improper voltage used.</li> <li>8. Wrong cable installed.</li> </ol>



**Important:** If the corrective actions above do not resolve the problem, contact your Chemelex representative for further assistance.

## Corrective Action

- (1) Set sensor control or thermostat to 50°F (10°C).
  - (2) Heating cables not energized soon enough. Check system controls. Adjust or modify operation.
  - (3) After snowfall ceases, manually energize system to melt remaining snow. (A typical Surface Snow Melting System is not designed to effectively melt all snow during the severest storms).
  - (4,5) Verify installation as per design. Contact Chemelex for assistance.
- 

- 1) Verify electrical connections to snow melting controller and sensor, verify supply voltage to controller, verify operation, and repair or replace controller or sensor if necessary.
  - (2) Verify electrical connections to thermostat, verify operation, and repair or replace thermostat if necessary.
  - (3) Confirm wiring using the normally closed (N.C.) terminals so that contacts close with falling temperature.
  - (4) Repair electrical supply lines and equipment.
  - (5) Repair or replace heating cable or cold lead.
  - (6) See above symptom under "Circuit breaker trips."
  - (7) Verify voltage and connect to proper voltage, if necessary.
  - (8) Verify installation as per design. Contact Chemelex for assistance.
-

## 10. INSTALLATION AND INSPECTION RECORDS

### Surface Snow Melting Installation Record

#### Installation Location

Project name: \_\_\_\_\_

Reference drawing: \_\_\_\_\_

Company: \_\_\_\_\_

Address: \_\_\_\_\_

State/Province: \_\_\_\_\_

Installation environment:  Commercial  Industrial  Hazardous Area

If installed in a hazardous area, fill in the following additional information:

Area: Ignition temperature \_\_\_\_\_ °F  °C

Group classification \_\_\_\_\_

Heating cable temp code/ sheath temp. (from tag) \_\_\_\_\_

#### Installed by

Company: \_\_\_\_\_

Address: \_\_\_\_\_

State/Province: \_\_\_\_\_

Name: \_\_\_\_\_

#### Visual Inspection (check for all heating cables and cold leads)

##### Cold Lead:

Steel angle iron and RTV/silicone compound is used to cross concrete crack control and expansion joints? Yes

The hot/cold joints are 6 in (15 cm) in from edge of heated area? Yes

The cold lead is protected where it emerges from the heated area? Yes

Hot/cold joints are spaced at least 6 in (15 cm) apart? Yes

All junction boxes are mounted above grade, and installed so that water cannot enter them? Yes

The cable sheath is securely connected to ground? Yes   
NPT threaded connectors must be properly grounded.

Installation date: \_\_\_\_\_

Area size \_\_\_\_\_ sq ft  sq m

City: \_\_\_\_\_

Postal code: \_\_\_\_\_

City \_\_\_\_\_

Postal Code: \_\_\_\_\_

Phone \_\_\_\_\_

### Heating Cable:

Cable spacing is as specified for the design? Yes

Enter spacing: \_\_\_\_\_ in  cm

Rebar or mesh is adequately supported? Yes

Heating cable is fastened to rebar or mesh using plastic tie-wraps? (Single pour concrete installation only) Yes

Heating cable is fastened to prepunched strapping, set at 3–4 ft (0.9–1.2 m) spacing? (2-pour concrete and asphalt installations) Yes

Location of all concrete crack control/expansion joints identified before pouring? Yes

Heating cable crosses expansion joints as shown in Section 2, Figure 10? Yes

Steel angle iron and RTV/silicone is used to cross concrete crack control joints Yes

Heating cable jacket is not damaged? Yes

Heating cables are not grouped, touching or crossed? Yes

Heating cables are not spaced closer than 3 in (7.5 cm) apart? Yes

Heating cables are not in contact with insulating material? Yes

Heating cables are installed in accordance with manufacturer's recommendations for concrete, asphalt, or pavers? Yes

# Electrical Testing

Note: Minimum acceptable insulation resistance shall be 20 MΩ (100 MΩ upon receipt)  
 Conduct insulation resistance tests at 1000 Vdc  
 (bypass controller if applicable)

Megohmmeter manufacturer/model \_\_\_\_\_

Multimeter manufacturer/model \_\_\_\_\_

## 1 Receipt of Material

	Heating Cable Catalog No. /Tag No.	Insulation Resistance (MΩ)	Continuity (Ω)
Cable #1	_____	_____	_____
Cable #2	_____	_____	_____
Cable #3	_____	_____	_____
Cable #4	_____	_____	_____
Cable #5	_____	_____	_____
Cable #6	_____	_____	_____
Cable #7	_____	_____	_____
Cable #8	_____	_____	_____
Cable #9	_____	_____	_____
Cable #10	_____	_____	_____
Cable #11	_____	_____	_____
Cable #12	_____	_____	_____

## 3 Initial Start-up (Commissioning)

**Warning:** Disconnect all power before conducting insulation resistance and continuity tests.

	Heating Cable Catalog No. /Tag No.	Heating Cable Location	Breaker Number
Cable #1	_____	_____	_____
Cable #2	_____	_____	_____
Cable #3	_____	_____	_____
Cables 1,2,3 three phase connected	Yes <input type="checkbox"/> No <input type="checkbox"/>	Delta <input type="checkbox"/> Wye <input type="checkbox"/>	
Cable #4	_____	_____	_____
Cable #5	_____	_____	_____
Cable #6	_____	_____	_____
Cables 4,5,6 three phase connected	Yes <input type="checkbox"/> No <input type="checkbox"/>	Delta <input type="checkbox"/> Wye <input type="checkbox"/>	
Cable #7	_____	_____	_____
Cable #8	_____	_____	_____
Cable #9	_____	_____	_____
Cables 7,8,9 three phase connected	Yes <input type="checkbox"/> No <input type="checkbox"/>	Delta <input type="checkbox"/> Wye <input type="checkbox"/>	
Cable #10	_____	_____	_____
Cable #11	_____	_____	_____
Cable #12	_____	_____	_____
Cables 10,11,12 three phase connected	Yes <input type="checkbox"/> No <input type="checkbox"/>	Delta <input type="checkbox"/> Wye <input type="checkbox"/>	
Ground-fault protection (type)	_____		
Test ground fault	_____		
Test controller	_____		
Test slab sensing thermostat	_____		
Topping material (check one):	Concrete <input type="checkbox"/> Asphalt <input type="checkbox"/> Pavers <input type="checkbox"/>		
Contractor's signature:	_____		
Accepted by:	_____		
Date:	_____		

Fax completed form to (650) 474-7657 to apply for 10-year Limited Warranty Extension



# Maintenance Log Record

Area location: \_\_\_\_\_

## Circuit Information

Breaker panel number: \_\_\_\_\_

## Visual

### Surface snow melting or anti-icing system

Enclosures, junction boxes, contactors sealed \_\_\_\_\_

Presence of moisture \_\_\_\_\_

Signs of corrosion \_\_\_\_\_

Damage to cold lead or termination \_\_\_\_\_

## Electrical Testing

Conduct insulation resistance test at 1000 Vdc  
(bypass controller is applicable)

 **Warning:** Disconnect all power before conducting insulation resistance and continuity tests.

Heating Cable Catalog No. /Tag No.	Heating Cable Location	Breaker Number
Cable #1 _____	_____	_____
Cable #2 _____	_____	_____
Cable #3 _____	_____	_____
Cables 1,2,3 three phase connected Yes <input type="checkbox"/> No <input type="checkbox"/> Delta <input type="checkbox"/> Wye <input type="checkbox"/>		
Cable #4 _____	_____	_____
Cable #5 _____	_____	_____
Cable #6 _____	_____	_____
Cables 4,5,6 three phase connected Yes <input type="checkbox"/> No <input type="checkbox"/> Delta <input type="checkbox"/> Wye <input type="checkbox"/>		
Cable #7 _____	_____	_____
Cable #8 _____	_____	_____
Cable #9 _____	_____	_____
Cables 7,8,9 three phase connected Yes <input type="checkbox"/> No <input type="checkbox"/> Delta <input type="checkbox"/> Wye <input type="checkbox"/>		
Cable #10 _____	_____	_____
Cable #11 _____	_____	_____
Cable #12 _____	_____	_____
Cables 10,11,12 three phase connected Yes <input type="checkbox"/> No <input type="checkbox"/> Delta <input type="checkbox"/> Wye <input type="checkbox"/>		
Ground-fault protection (type) _____		
Test ground fault _____		
Test automatic snow melting controller _____		
Test slab sensing thermostat _____		

Comments and actions \_\_\_\_\_

Prepared by: \_\_\_\_\_

Approved by: \_\_\_\_\_



## **North America**

Tel +1.800.545.6258

info@chemelex.com

## **Latin America**

Tel +1 713 868 4800

info@chemelex.com

---

**chemelex**  
*excellence is everything*

**chemelex.com**

**Raychem Tracer Pyrotenax Nuheat**

©2025 Chemelex. All Chemelex marks and logos are owned or licensed by Chemelex Europe GmbH or its affiliates. All other trademarks are the property of their respective owners. Chemelex reserves the right to change specifications without notice.

RAYCHEM-IM-H57754-SurfaceSnowMelting-EN-2504

PCN 732863-000