

Raychem

XL-Trace Edge System

Installation and Operation Manual for Pipe
Freeze Protection and Flow Maintenance

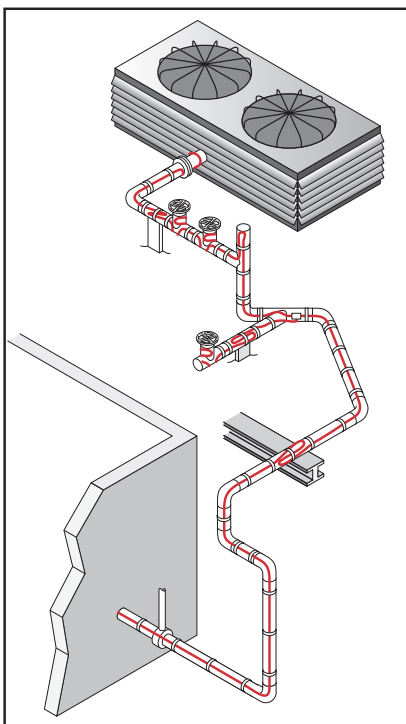

Important Safeguards and Warnings

WARNING: FIRE AND SHOCK HAZARD.

Raychem heat-tracing systems must be installed correctly to ensure proper operation and to prevent shock and fire. Read these important warnings and carefully follow all the installation instructions.

- To minimize the danger of fire from sustained electrical arcing if the heating cable is damaged or improperly installed, and to comply with Chemelex requirements, agency certifications, and national electrical codes, ground-fault equipment protection must be used on each heating cable branch circuit. Arcing may not be stopped by conventional circuit breakers.
- Approvals and performance are based on the use of Chemelex-specified parts only. Do not substitute parts or use vinyl electrical tape.
- Bus wires will short if they contact each other. Keep bus wires separated.
- Connection kits and cable ends must be kept dry before and during installation.
- The black heating cable core is conductive and can short. It must be properly insulated and kept dry.
- Damaged bus wires can overheat or short. Do not break bus wire strands when preparing the cable for connection.
- Damaged heating cable can cause electrical arcing or fire. Do not use metal attachments such as pipe straps or tie wire. Use only Chemelex approved tapes and cable ties to secure the cable to the pipe.
- Do not attempt to repair or energize damaged heating cable. Remove damaged sections at once and replace them with a new length using the appropriate Raychem splice kit. Replace damaged connection kits.
- Use only fire-resistant insulation materials such as fiberglass wrap or flame-retardant foams.

Note: Pipes are shown without insulation for illustrative purposes only. All pipe installations must be fully covered with thermal insulation.

Table of Contents

1	General Information	1
	1.1 Use of the Manual	1
	1.2 XL-Trace Edge Applications	2
	1.3 Safety Guidelines	2
	1.4 Approvals	3

2	Installation Guidelines	4
	2.1 Heating Cable Storage	4
	2.2 Pre-Installation Checks	4
	2.3 Heating Cable Installation	5
	2.4 Heating Cable Connections	19

3	Thermal Insulation	27
	3.1 Insulating the System	27
	3.2 Insulation Installation	27

4	Power Supply and Electrical Protection	30
	4.1 Voltage Rating	30
	4.2 Circuit Breaker Sizing	30
	4.3 Electrical Loading	30
	4.4 Ground-Fault Protection	30
	4.5 Important Power Supply Safeguards	31

5	Control, Monitoring and Power Distribution	32
	5.1 Control Systems	32
	5.2 Power Distribution	35

6	Commissioning and Preventive Maintenance	38
	6.1 Tests	38

7	Test Procedures	40
	7.1 System Tests	40
	7.2 Fault Location Tests	45

8	Troubleshooting Guide	50
----------	------------------------------	-----------

9	Appendix	52
----------	-----------------	-----------

10	Installation and Inspection Records	58
-----------	--	-----------

1

General Information

1.1 Use of the Manual

This manual covers the installation of Raychem XL-Trace Edge self-regulating heating cables and connections for commercial construction pipe systems in ordinary (nonhazardous) areas. The manual covers general heating cable installation procedures and specific installation details and shows available connection kits for the different applications. The manual also discusses controls, testing, and periodic maintenance.

This manual assumes that the proper heat-tracing design has been completed according to the Pipe Freeze Protection and Flow Maintenance Design Guide (H55838). Only the applications described in Section 1.2 are approved by Chemelex for XL-Trace Edge systems when used with approved Raychem connection kits. The instructions in this manual and the installation instructions included with the connection kits, control systems, power distribution systems, and accessories must be followed for the Chemelex warranty to apply. Contact your Chemelex representative for other applications and products.

For additional information, contact:

Chemelex

Tel: +1.800.545.6258

Fax: +1.800.527.5703

info@chemelex.com

chemelex.com

1

General Information

1.2 XL-Trace Edge Applications

XL-Trace Edge heat-tracing systems are approved and qualified for the applications listed below.

Freeze protection

- **General water piping.** Freeze protection (40°F (4°C) maintain) of insulated metallic or plastic water piping.
- **Sprinkler piping systems.** Freeze protection (40°F (4°C) maintain) of insulated metallic standpipes and supply piping up to 20".

Flow maintenance

- **Greasy waste lines.** Flow maintenance (110°F (43°C) maintain) of insulated-grease disposal lines.
- **Fuel lines.** Flow maintenance (40°F (4°C) maintain) for insulated metallic piping containing #2 fuel oil.

For heating cable applications other than those listed above, please see your Chemelex representative or call Chemelex at (800) 545-6258.



Note: 3XLE is approved for freeze protection of general water piping only.

1.3 Safety Guidelines

As with any electrical equipment, the safety and reliability of any system depends on the quality of the products selected and the manner in which they are installed and maintained. Incorrect design, handling, installation, or maintenance of any of the system connection kits could damage the system and may result in inadequate performance, overheating, electric shock, or fire. To minimize these risks and to ensure that the system performs reliably, read and carefully follow the information, warnings, and instructions in this guide.

Pay special attention to the following:

- Important instructions are marked  **Important**

1

General Information

- Warnings are marked  **WARNING**

1.4 Approvals

XL-Trace Edge heat-tracing systems carry agency approvals for the different applications shown in Section 1.2. For detailed information on which approvals are carried for the specific application, refer to the Pipe Freeze Protection and Flow Maintenance design guide (H55838).

Warranty

Chemelex standard limited warranty applies to all products.



An extension of the limited warranty period to ten (10) years from the date of installation is available if a properly completed online warranty form is submitted within thirty (30) days from the date of installation. You can access the complete warranty on our website at <https://raychem.nvent.com/en-us/support/warranty-information>.

2

Installation Guidelines

2.1 Heating Cable Storage

- Store the heating cable in a clean, dry location. Temperature range: 0°F (-18°C) to 140°F (60°C).
- Protect the heating cable from mechanical damage.

2.2 Pre-Installation Checks

Check materials received

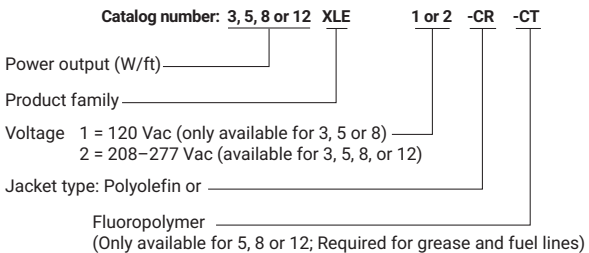

 **Note: 3XLE is approved for freeze protection of general water piping only.**

Figure 1: XL-Trace Edge catalog number

- Review the heating cable design and compare the list of materials to the catalog numbers of the heating cables and connection kits received to confirm that the proper materials are on site. The heating cable type is printed on its jacket.
- Ensure that the service voltage available is correct for the XL-Trace Edge heating cable selection.
- Inspect the heating cable and connection kits to ensure there is no in-transit damage.
- Verify the system design does not exceed the maximum exposure temperature of 185°F (85°C).
- Verify that the heating cable jackets are not damaged by conducting the insulation resistance test (refer to Section 7) on each reel of heating cable. Do not power the heating cable when it's on the reel.

2

Installation Guidelines

Check piping to be traced

- Make sure all mechanical pipe testing (i.e. hydrostatic testing/purging) is complete and the system has been cleared by the client for tracing.
- Walk the system and plan the routing of the heating cable on the pipe.
- Inspect the piping and remove any burrs, rough surfaces, or sharp edges.

2.3 Heating Cable Installation

Minimum installation temperature of: 0°F (-18°C).

Heating cable installation involves three basic steps:

1. Paying out the heating cable
2. Attaching the heating cable to the pipe
3. Wrapping heat sinks

Paying out the heating cable

Mount the reel on a holder and place it near either end of the pipe run to be traced. Use a reel holder that pays out smoothly with little tension as shown in Figure 2. Avoid jerking the heating cable while pulling.

Pay out the heating cable and loosely string it along the pipe, making sure the heating cable is always next to the pipe when crossing obstacles. If the heating cable is on the wrong side of a crossing pipe or I-beam, you will have to reinstall it or cut and splice it.

2

Installation Guidelines

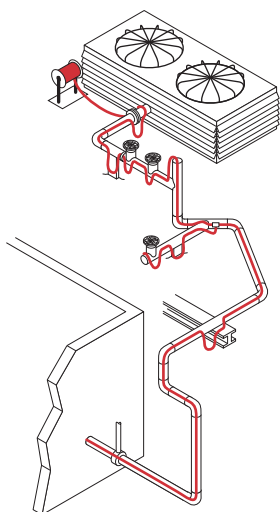

Figure 2: Paying out the heating cable

When paying out the heating cable, AVOID:

- Sharp edges
- Excessive pulling force or jerking
- Kinking or crushing
- Walking on or running over the heating cable with equipment

⚠ WARNING: Fire and shock hazard. Do not install damaged heating cable. Connection kits and heating cable ends must be kept dry before and during installation.

Attaching the heating cable

Once the heating cable has been run for the entire section, begin fastening it to the pipe. Start at the end and work toward the reel. The additional heating cable required for valves and other heat sinks is shown in Table 1 and Table 2. Refer to Table 3 for the additional heating cable required for connection kits. The heating cable may be installed in single or in multiple runs as required by the design.

2

Installation Guidelines

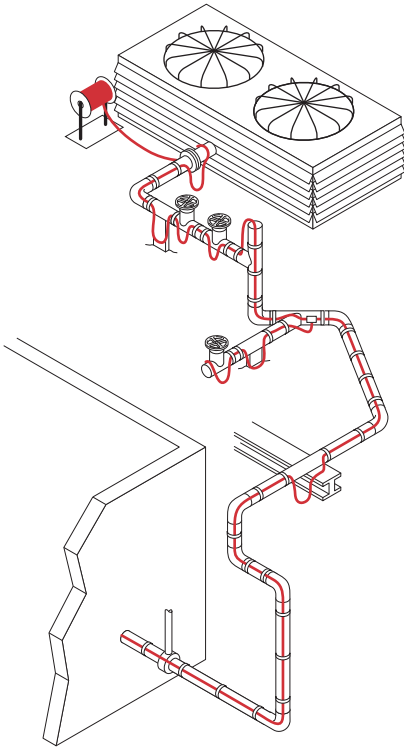

Figure 3: Attaching the heating cable

2

Installation Guidelines

TABLE 1: ADDITIONAL HEATING CABLE FOR VALVES

Pipe diameter (IPS)	Heating cable in feet (meters)	
1/2	0.8	(0.24)
3/4	1.3	(0.4)
1	2.0	(0.6)
1-1/4	3.3	(1.1)
1-1/2	4.3	(1.3)
2	4.3	(1.3)
3	4.3	(1.3)
4	4.3	(1.3)
6	5.0	(1.5)
8	5.0	(1.5)
10	5.6	(1.7)
12	5.9	(1.9)
14	7.3	(2.2)
18	9.4	(2.9)
20	10.5	(3.2)

TABLE 2: ADDITIONAL HEATING CABLE FOR PIPE SUPPORTS AND FLANGES

Support	Additional heating cable
Pipe hangers (insulated)	No additional heating cable
Pipe hangers noninsulated and U-bolt supports:	Add 2x pipe diameter
Welded support shoes	Add 3x the length of the shoe
Flanges	Add 2x pipe diameter

Note: For applications where more than one heating cable is required per foot of pipe, this correction factor applies for each heating cable run.

2

Installation Guidelines

- Run insulation through the pipe hanger ensuring that the pipe is not resting on the heater.

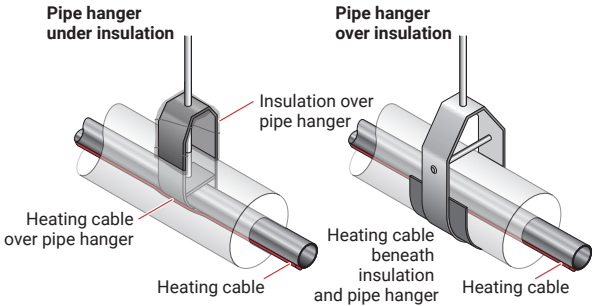

Figure 4: Pipe hanger with heating cable

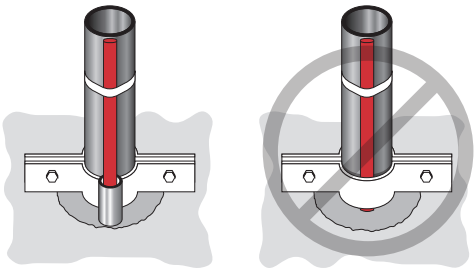

Figure 5: Single pipe floor penetration

- When making floor or wall penetrations, make sure the hole is large enough to accommodate the pipe and the thermal insulation. When sealing around pipes at floor penetrations, avoid damaging or cutting the heating cable, or pinching it between the pipe and the concrete.

2

Installation Guidelines

- The heating cable must not be embedded directly in the sealing material; the pipe should have thermal insulation over it (if allowed by local codes) or the heating cable should be run through the penetration in a tube or conduit. If the conduit must be sealed, use a pliable fire-resistant material (Dow Corning Fire Stop, 3M Fire Barrier, or T&B Flame-Safe) that can be removed if necessary.

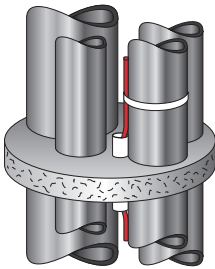

Figure 6: Multiple pipe floor penetration

- On vertical piping groups, run the heating cable along the inside of the pipe close to other pipes so it will not be damaged if the pipe hits the side of the floor penetration. Run the heating cable over the outside of the pipe support. Do not clamp the heating cable to the pipe with the pipe support.
- In high-rise construction it may be necessary to install the XL-Trace Edge system 10 or 12 floors at a time to fit into the construction schedule. If so, the end of the heating cable should be sealed with a RayClic-E end seal and placed in an accessible location. This allows testing of one part of the heating cable at a time, and allows splicing it to another section when the system is complete.
- When XL-Trace Edge is installed behind walls, the power connection kit must be accessible.

Whenever possible, position the heating cable on the lower section of the pipe as shown in Figure 7 to protect it from damage.

2

Installation Guidelines

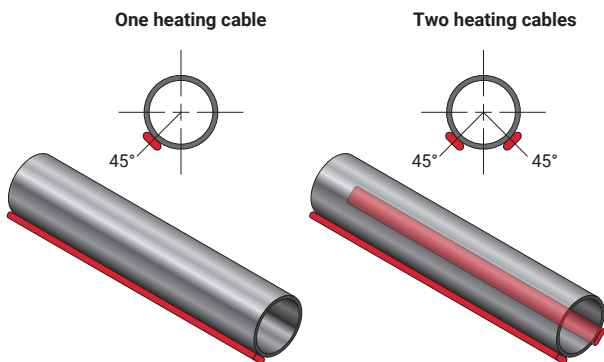

Figure 7: Positioning the heating cable

Securing the heating cable

⚠ WARNING: Damage to the heating cable can cause electrical arcing or fire. Do not use metal attachments such as pipe straps or tie wire. Use only Chemelex-approved tapes or plastic cable ties.

🔪 Important: Before taping the heating cable to the pipe, make sure all heat-tracing allowances for flanges, valves, supports, and other connection kits have been verified.

Use one of the following attachment methods to secure the heating cable onto the pipe: GT-66 or GS-54 glass cloth tape, AT-180 aluminum tape, or plastic cable ties.

GLASS CLOTH ADHESIVE TAPE

- GT-66 (66-foot roll) general-purpose tape for installation at 40°F (4°C) and above. Apply at 1-foot intervals.
- GS-54 (54-foot roll) general-purpose tape for installation below 40°F (4°C). Apply at 1-foot intervals.

AT-180 ALUMINUM TAPE

- Required for plastic pipe applications to ensure proper power output of heating cable.

2

Installation Guidelines

- Tape lengthwise over the heating cable as required by the design drawing or specification (see Figure 8).
- Recommended for heat-tracing pump bodies or odd-shaped equipment, or as called out in the design drawing as a heat-transfer aid.
- Install at temperatures above 32°F (0°C).

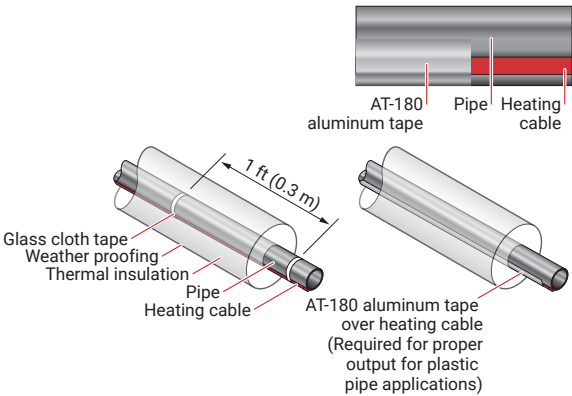

Figure 8: Attaching the heating cable

CABLE TIES

- Recommended in applications where the pipe surface prevents proper tape adhesion.
- Use plastic cable ties only.
- Cable ties must be hand-tightened only to prevent damage to heating cable!

Bending/Crossing/Cutting the Heating Cable

BENDING THE HEATING CABLE

When positioning the heating cable on the pipe, do not bend tighter than 1/2" radius. The heating cable does not bend easily in the flat plane. Do not force such a bend, as the heating cable will be damaged.

2

Installation Guidelines

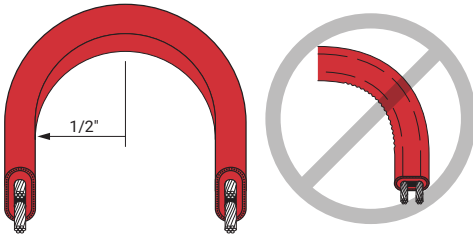

Figure 9: Bending technique

CROSSING THE HEATING CABLE

XL-Trace Edge heating cables are self-regulating and may be overlapped whenever necessary without overheating or burning out.

CUTTING THE HEATING CABLE

Cut the heating cable to the desired length after it is attached to the pipe. XL-Trace Edge can be cut to length without affecting the heat output per foot.

Wrapping the Heat Sinks

Once the straight sections are secured the heating cable can be secured to the heat sinks. Attach the heating cable to the heat sinks according to Figure 10 below. The length of heating cable installed is determined in the design.

2

Installation Guidelines

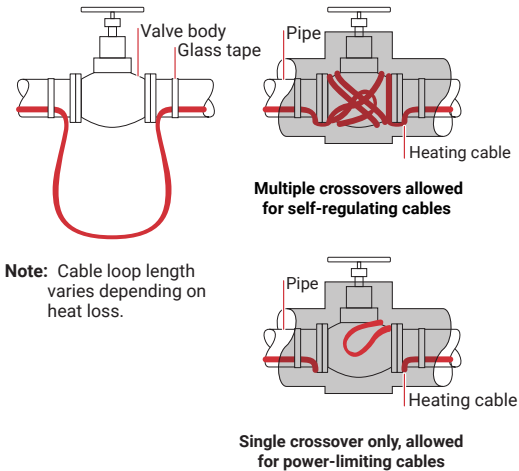

Figure 10: Valve

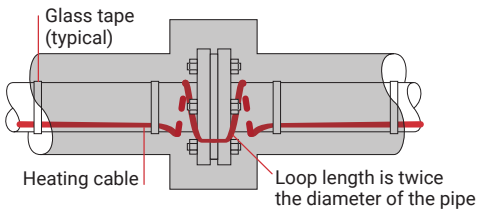

Figure 11: Flange

2

Installation Guidelines

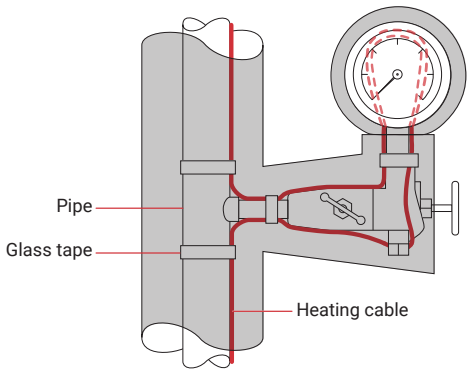

Figure 12: Pressure gauge

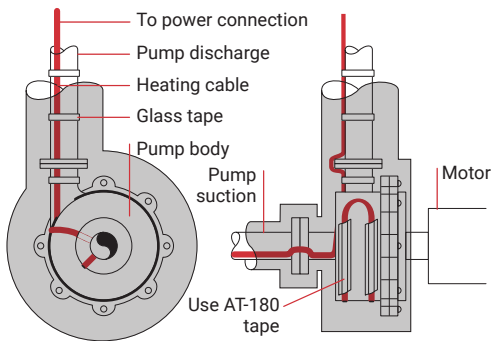

Figure 13: Split case centrifugal pump

2

Installation Guidelines

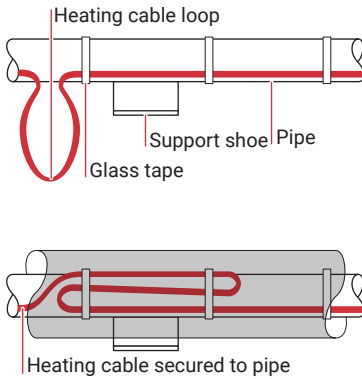

Figure 14: Pipe support shoe

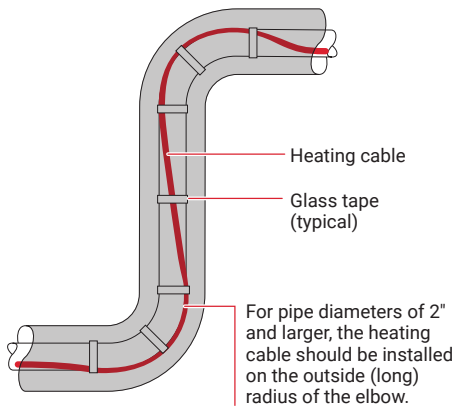
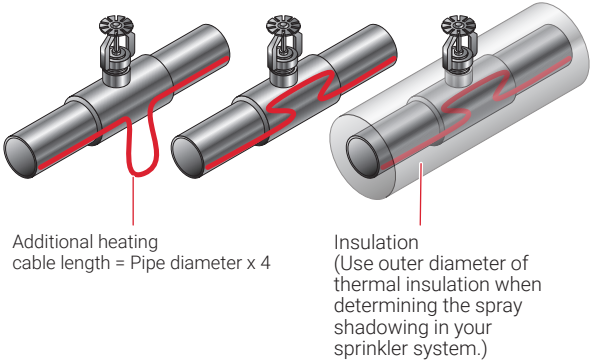

Figure 15: Elbow

2

Installation Guidelines

Sprinkler head without sprig



Sprinkler head with sprig

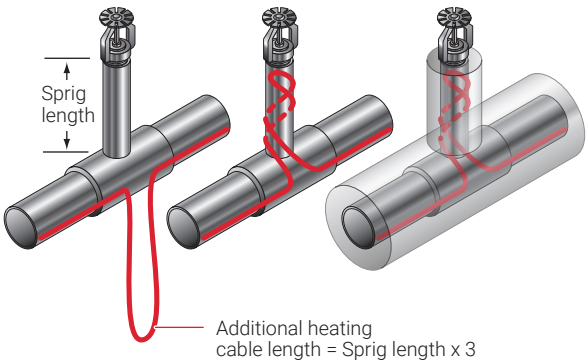



Figure 16: XL-Trace Edge on sprinklers

 **Note:** The orientation and type of sprinkler head shown above is only for reference. The illustrations only depict the amount of heat tracing required and how to install it.

2

Installation Guidelines

When installing XL-Trace Edge on dry pendant sprinklers used in freezer applications follow the methods shown below:

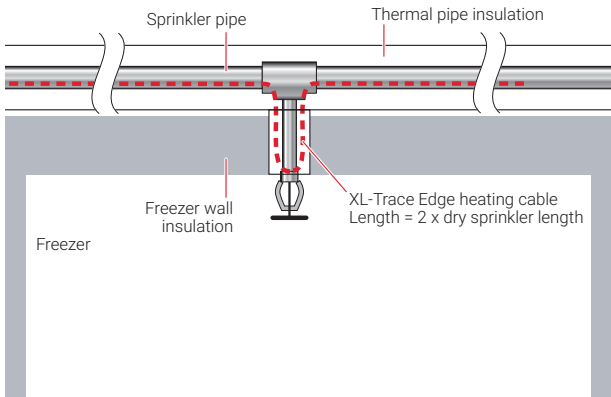

Figure 17: XL-Trace Edge on extended pendant sprinklers

2

Installation Guidelines

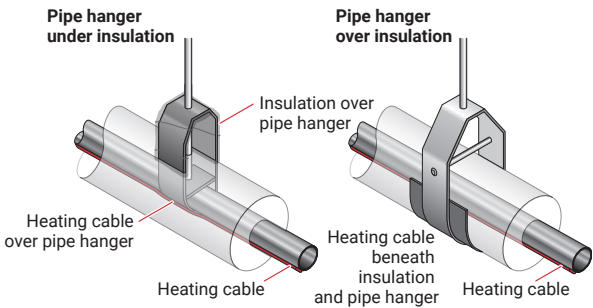

Figure 18: Pipe hanger

2.4 Heating Cable Connections

General Requirements

All XL-Trace Edge systems require a power connection and end seal kit. Splice and tee kits are used as required. Use Table 3 (for aboveground applications) and Table 4 (for belowground applications) to select the appropriate connection kits.

When practical, mount connection kits on top of the pipe. Electrical conduit leading to power connection kits must have low-point drains installed to avoid condensation entry into the heating system. All heating cable connections must be mounted above grade level.

If your design has an exposure temperature $>150^{\circ}\text{F}$ (65°C) but $< 185^{\circ}\text{F}$ (85°C), install all connections kits off the pipe.

⚠ WARNING: Connection kit approvals and performance are based on the use of specified parts only. Do not use substitute parts or vinyl electrical tape. Follow installation instructions provided with each kit.

2

Installation Guidelines

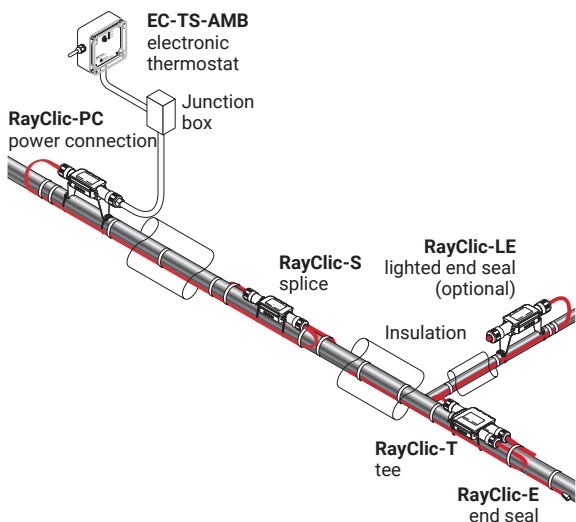

Figure 19: Aboveground XL-Trace Edge System

Use Table 3 for general aboveground piping, sprinkler piping, and grease and fuel lines. Allow extra heating cable for ease of connection kit installation.

2

Installation Guidelines

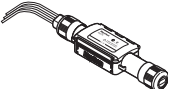
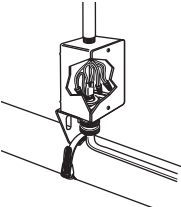
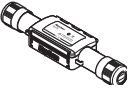
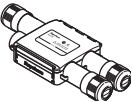
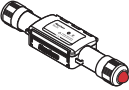
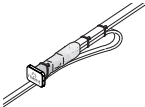

TABLE 3: CONNECTION KITS FOR GENERAL ABOVEGROUND PIPING

Catalog number	Description	Heating cable allowance ¹
 RayClic-PC ^{2,3}	Power connection and end seal kit; use 1 per circuit Standard pkg: 1	2 ft (0.6 m)
 FTC-P ^{4,5}	Power connection and end seal kit; use 1 per circuit Standard pkg: 1 Junction box not included	2 ft (0.6 m)
 RayClic-S ^{2,3,6}	Splice used to join two sections of heating cable Standard pkg: 1	2 ft (0.6 m)
 RayClic-T ^{2,6}	Tee kit with end seal; use as needed for pipe branches Standard pkg: 1	2 ft (0.6 m)
 RayClic-LE	Alternate lighted end seal Standard pkg: 1	2 ft (0.6 m)

2

Installation Guidelines

TABLE 3: CONNECTION KITS FOR GENERAL ABOVEGROUND PIPING

Catalog number	Description	Heating cable allowance ¹
Continued		
 FTC-HST-PLUS ⁴	Low-profile splice/tee; use as needed for pipe branches Standard pkg: 2	3 ft (0.9 m)
 RayClic-E ³	Replacement end seal Standard pkg: 1	0.3 ft (0.1 m)

¹ For ease of component installation, allow extra heating cable.

² Powered splice, powered tee, and cross (tee with three legs) connections are also available.

³ For grease and fuel lines, install RayClic-LE or end seal off the pipe in junction box.

⁴ Not permitted with grease or fuel lines.





⁵ Use for circuits supplied with 40 A circuit breaker.

⁶ For grease and fuel lines, install tees and splices on pipe mounting bracket (RayClic-SB-04).

2

Installation Guidelines

TABLE 4: ACCESSORIES FOR GENERAL ABOVEGROUND PIPING

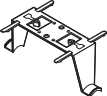
Catalog number	Description	Heating cable allowance
 ETL	"Electric Traced" label (use 1 label per 10 feet of pipe)	10 labels
 GT-66	Glass cloth adhesive tape for attaching heating cable to pipe at 40°F (4°C) or above. See Table 7.	66 ft
 GS-54	Glass cloth adhesive tape for attaching heating cable to pipe above -40°F (-40°C). See Table 7.	54 ft
 AT-180	Aluminum tape. Required for attaching heating cable to plastic pipe (use 1 foot of tape per foot of heating cable).	180 ft
 RayClic-SB-04	Pipe mounting bracket. Required for mounting the kits off the pipe for exposure temperatures greater than 150°F (65°C) and for grease and fuel line splices and tees.	1 ea

2

Installation Guidelines

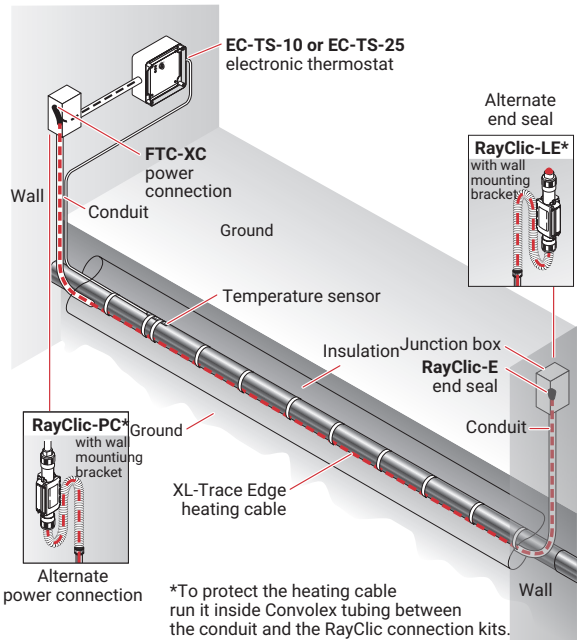

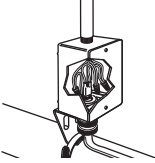
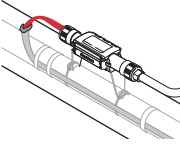

Figure 20: Buried pipe XL-Trace System

Warning: all heating cable connections (power, splice, tee, and end termination) are made above-ground. no buried or in-conduit splices or tees are allowed.

2

Installation Guidelines

TABLE 5: CONNECTION KITS FOR GENERAL BURIED PIPING

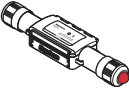
Catalog number	Description	Heating cable allowance*
 FTC-XC	<ul style="list-style-type: none">• Power connection and end seal• Junction box supplied by customer• Use 1 per circuit Standard pkg: 1	2 ft (0.6 m)
 RayClic-PC	Power connection and end seal kit Standard pkg: 1	
 RayClic-E	Replacement end seal. Standard pkg: 1	0.3 ft (0.1 m)
 RayClic-LE	Alternate lighted end seal Standard pkg: 1	2 ft (0.6 m)

* For ease of connection kit installation, allow extra heating cable.

2

Installation Guidelines

TABLE 6: ACCESSORIES FOR GENERAL BURIED PIPING

Catalog number	Description	Standard pkg
ETL	"Electric Traced" label (use 1 label per 10 feet of pipe)	10 labels
GT-66	Glass cloth adhesive tape for attaching heating cable to pipe at 40°F (4°C) or above. See Table 7.	66 ft
GS-54	Glass cloth adhesive tape for attaching heating cable to pipe above -40°F (-40°C). See Table 7.	54 ft
AT-180	Aluminum tape. Required for attaching heating cable to plastic pipe (use 1 foot of tape per foot of heating cable).	180 ft
RayClic-SB-02	Wall mounting bracket	1

TABLE 7: QUANTITY OF GLASS CLOTH ADHESIVE TAPE REQUIRED (ATTACH AT 1-FOOT INTERVALS)

Pipe size (in)	<2	3	4	6	8	10
Feet of pipe per GT-66 roll	60	50	40	25	20	15
Feet of pipe per GS-54 roll	49	41	33	20	16	12

3

Thermal Insulation

3.1 Insulating the System

Pipes must be insulated with the correct thermal insulation to maintain the desired pipe temperatures. Confirm that the insulation thickness agrees with the system design.

3.2 Insulation Installation

- Before insulating the pipe, visually inspect the heating cable and connection kits to ensure they are properly installed and there are no signs of damage. Damaged heating cable or connection kits must be replaced.
- Check that the insulation type and thickness is correct.
- Insulate the pipes immediately after the heating cable is installed and has passed all tests to minimize damage to the heating cable.
- Insulate the pipe at floor and wall penetrations. Failure to do so will cause cold spots in the water system and could lead to damage to the heating cable. If local codes do not allow this, the heating cable should be run through a conduit or channel before the firestop is installed. Use a fire-resistant sealing compound such as Dow Corning Fire Stop, 3M Fire Barrier, or T&B Flame-Safe.
- Do not use staples to seal insulation. Use tape or the adhesive-lined edge of the insulation to ensure that the seam remains sealed. Staples can damage the heating cable.

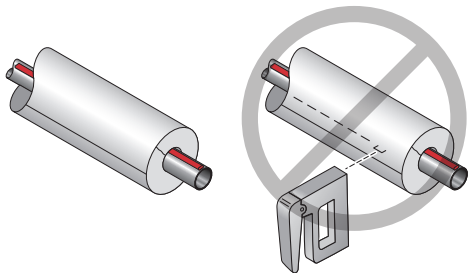

Figure 21: Sealing the insulation seam

3

Thermal Insulation

- All systems for outdoor, buried, or wet areas must use waterproof fire-resistant thermal insulation.
- Mark the location of splices, tees, and end seals on the outside of the insulation with labels provided in the kits, while installing the insulation. Use large diameter insulation or sheets to cover splices, tees, or service loops.

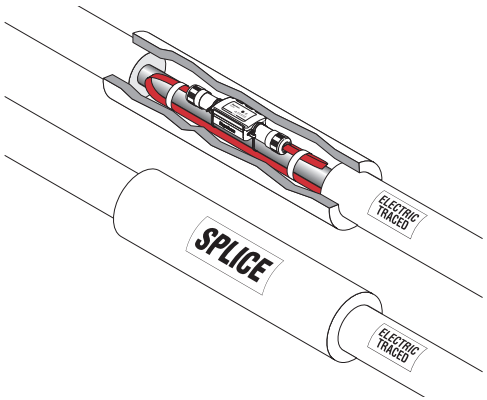

Figure 22: Installing connection kits below insulation

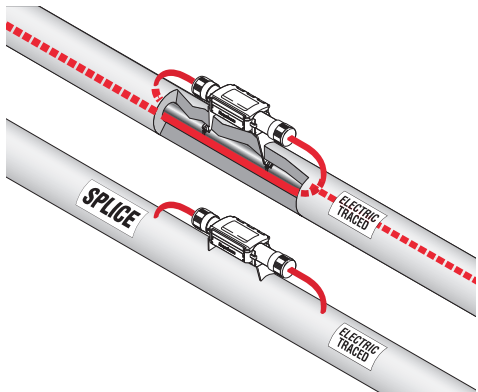

Figure 23: Installing connection kits above insulation

3

Thermal Insulation

- Make sure that all heat-traced piping, fittings, wall penetrations, and branch piping are insulated. Correctly designed systems require properly installed and dry thermal insulation. Uninsulated or wet sections of pipe can result in cold spots or frozen sections.
- After installing insulation, electrical codes require that you install “Electric Traced” labels along the piping at suitable intervals (10-foot intervals recommended) on alternate sides.

 **WARNING: Use only fire-resistant insulation materials such as fiberglass wrap or flame-retardant foams.**

4

Power Supply and Electrical Protection

4.1 Voltage Rating

Verify that the supply voltage is either 120 or 208–277 volts as specified by the XL-Trace Edge system design and printed on the jacket of the heating cable.

4.2 Circuit Breaker Sizing

Circuit breakers must be sized using the heating cable lengths shown in the Appendix. Do not exceed the maximum circuit length shown for each breaker size. Use circuit breakers that incorporate 30-mA ground-fault circuit protection, or provide equivalent levels of ground-fault protection.

4.3 Electrical Loading

The maximum current draw for XL-Trace Edge heating cables is shown in the Appendix. To size the transformer, multiply the total heating cable length (ft) by the appropriate current draw.

4.4 Ground-Fault Protection

If the heating cable is improperly installed or physically damaged to the point that water contacts the bus wires, sustained arcing or fire could result. If arcing does occur, the fault current may be too low to trip conventional circuit breakers. Chemelex and national electrical codes require both ground-fault protection of equipment and a grounded metallic covering on all heating cables. Ground-fault protection must be provided by the installer.



WARNING: To minimize the danger of fire from sustained electrical arcing if the heating cable is damaged or improperly installed, and to comply with Chemelex requirements, agency certifications, and national electrical codes, ground-fault equipment protection must be used on each heating cable branch circuit. Arcing may not be stopped by conventional circuit breakers.



WARNING: Disconnect all power before making connections to the heating cable.

4

Power Supply and Electrical Protection

4.5

Important Power Supply Safeguards

- Make sure that the heating cable load you are connecting is within the rating of the control system selected. Check the design drawings for the heating cable load.
- The electrical conduit that feeds wiring to the control device must have a low-point drain so condensation will not enter the thermostat enclosure.
- Make sure that the line voltage you are connecting to the control system is correct. For proper wiring, follow the installation instructions enclosed with the control device.

5

Control, Monitoring and Power Distribution

5.1 Control Systems

Electronic thermostats provide higher accuracy of the heating cable circuit with thermistor sensors and built-in ground-fault protection.

Electronic controllers provide superior accuracy with RTD temperature sensors, built-in ground-fault protection, monitoring and alarm output.

Ambient-Sensing Control

Ambient-sensing systems energize the circuit when the ambient temperature drops below the set point.

- Mount the device above grade level and out of sunlight.
- Mount the device where it will be exposed to the coldest temperature and the highest wind.

Line-Sensing Control



Line-sensing systems sense the pipe temperature by means of a sensor attached to the pipe and connected to the device.

- Install the sensor on the pipe at 90 degrees from the heating cable so that the heating cable does not thermally interfere with the sensor. Be sure the sensor is firmly attached with aluminum tape to the pipe in order to get good thermal contact between the bulb and the pipe.
- Locate the sensor at least 3 feet (1 meter) from any heat sinks, such as valves, pipe supports, and pumps. Ideally, the sensor should be located at the end of the heating cable circuit.
- Be sure that you set the control to the proper temperature.
- Mount the device on a nearby wall or support, or install a mounting stanchion. Thermostats must be mounted above grade level. In all cases, protect the sensor from physical damage. To prevent damage, mount the device where it will be away from foot and equipment traffic.
- To prevent water entry, seal the insulation where the capillary tube exits the insulation.

5

Control, Monitoring and Power Distribution

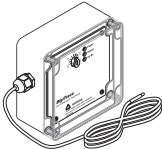
TABLE 1: CONTROL SYSTEMS

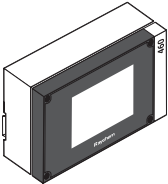
	Description
Electronic thermostats	
 <p>EC-TS</p>	<p>The EC-TS is an ambient or line-sensing electronic thermostat housed in a NEMA 4X enclosure with 2 x 1/2 in conduit entries for power and 1 gland entry for the sensor. The temperature set point and LED indicators for alarm, power, and heating cable status can be visually checked through the clear lid. Electrical rating is 30 A at 100–277 V, 50–60 Hz, SPST switch. The EC-TS includes a 25 ft (7.6 m) sensor.</p>
 <p>ECW-GF</p>	<p>The ECW-GF is an ambient or line-sensing electronic controller with 30-mA ground-fault protection. The controller can be programmed to maintain temperatures up to 200°F (93°C) at voltages from 100 to 277 V and can switch current up to 30 Amperes. The ECW-GF is complete with a 25-ft (7.6-m) temperature sensor and is housed in a NEMA 4X rated enclosure. The controller features an AC/DC dry alarm contact relay.</p>
 <p>ECW-GF-DP</p>	<p>An optional ground-fault display panel (ECW-GF-DP) can be added to provide ground-fault or alarm indication in applications where the controller is mounted in inaccessible locations.</p>
Electronic controllers and sensors	
 <p>460 & 465</p>	<p>The 460/465 controllers are single-point electronic heat tracing controllers designed for pipe freeze protection (460) and fire sprinkler systems (465). They feature a 5" inch color touch screen display for intuitive set up and programming right out of the box. These controllers may be used with line-sensing or ambient-sensing and proportional ambient-sensing control (PASC) modes, measuring temperatures with two Thermistor 2 KOhm / 77°F (25°C), 2-wire connected directly to the unit. The controllers can measure ground fault current to ensure system integrity.</p>

5

Control, Monitoring and Power Distribution

TABLE 1: CONTROL SYSTEMS

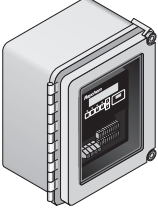
	Description
 <p data-bbox="111 739 243 771">C910-485</p>	<p data-bbox="401 416 932 916">The C910-485 is a compact, full-featured, microprocessor-based, single-point commercial heating cable control system with integrated equipment ground-fault protection. The C910-485 provides control and monitoring of electric heating cable circuits for commercial heating applications. The C910-485 can be set to monitor and alarm for high and low temperature, low current, and ground-fault level. The C910-485 includes a communication module to remotely configure, control and monitor the heating cable circuits through a building management system (BMS).</p>

5

Control, Monitoring and Power Distribution

TABLE 2: CONTROL SYSTEMS

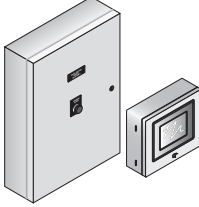
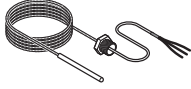
	Description
 <p data-bbox="103 722 269 808">ACS-UIT3 ACS-PCM2-5</p>	<p data-bbox="398 420 932 625">The ACS-30 Advanced Commercial Control System is a multipoint electronic control and monitoring system for heat-tracing used in commercial freeze protection and flow maintenance applications.</p> <p data-bbox="398 636 932 894">The ACS-30 system can control up to 260 circuits with multiple networked ACS-PCM2-5 panels, with a single ACS-UIT3 user interface terminal. The ACS-PCM2-5 panel can directly control up to 5 individual heat-tracing circuits using electromechanical relays rated at 30 A up to 277 V.</p>
 <p data-bbox="103 1088 181 1131">RTDs</p>	<p data-bbox="398 916 932 1024">Stainless steel jacketed three-wire RTD (Resistance Temperature Detector) used with C910-485 and ACS-30 controllers.</p> <p data-bbox="398 1034 932 1142">RTD-200: 3-in (76 mm) temperature sensor with a 6-ft (1.8 m) lead wire and 1/2-in NPT bushing</p> <p data-bbox="398 1153 932 1261">RTD3CS: temperature sensor with a 3-ft (0.9 m) flexible armor, 18-in (457mm) lead wire and 1/2-in NPT bushing</p> <p data-bbox="398 1272 932 1422">RTD10CS: temperature sensor with a 10-ft (3 m) flexible armor, 18-in (457 mm) lead wire and 1/2-inch NPT bushing</p> <p data-bbox="398 1433 932 1541">RTD50CS: temperature sensor with a 50-ft (3 m) flexible armor, 18-in (457 mm) lead wire and 1/2-in NPT bushing</p>

5

Control, Monitoring and Power Distribution

5.2 Power Distribution

Once the heating cable circuits have been defined, you must select how to provide power to them. Power to the XL-Trace Edge heating cables can be provided in several ways: directly through the temperature control, through external contactors, or through HTPG power distribution panels.

Typical Wiring Schematics

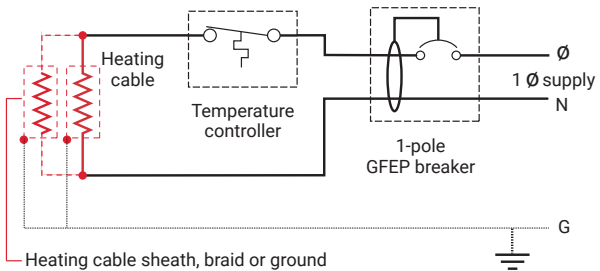

Figure 24: Single circuit control

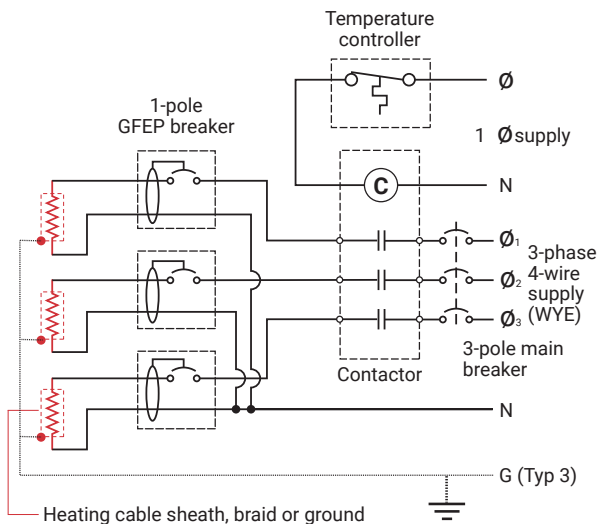
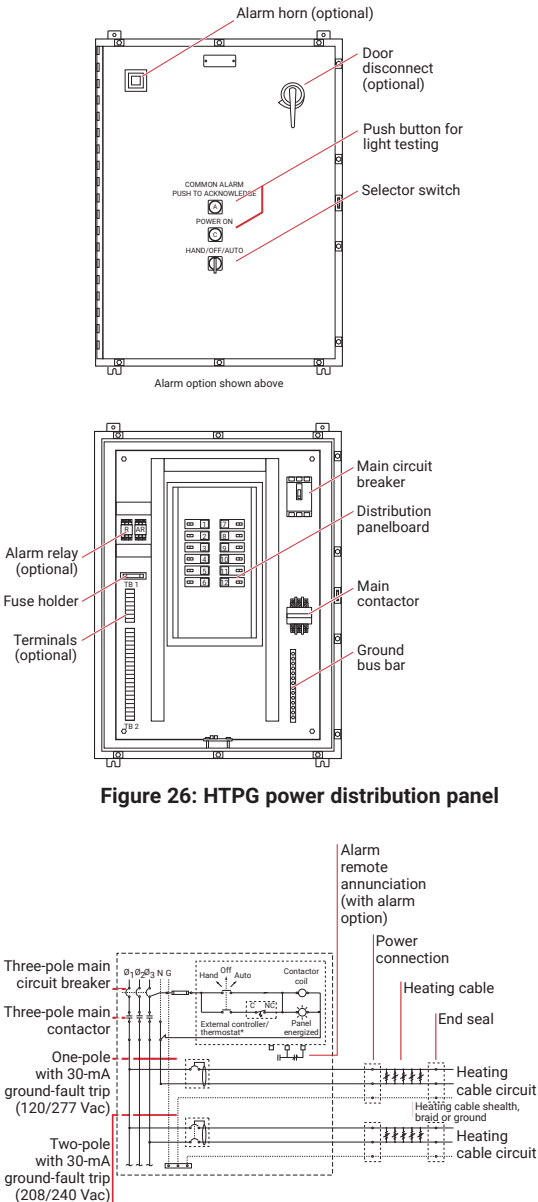

Figure 25: Group circuit control

5

Control, Monitoring and Power Distribution



6

Commissioning and Preventive Maintenance

Chemelex requires a series of commissioning tests be performed on the XL-Trace Edge system. These tests are also recommended at regular intervals for preventive maintenance. Results must be recorded and maintained for the life of the system, utilizing the "Installation and Inspection Record" (refer to Section 9). Submit this manual with initial commissioning test results to the owner.

6.1 Tests

A brief description of each test is found below. Detailed test procedures are found in Section 7.

Visual Inspection

Visually inspect the pipe, insulation, and connections to the heating cable for physical damage. Check that no moisture is present, electrical connections are tight and grounded, insulation is dry and sealed, and control and monitoring systems are operational and properly set. Damaged heating cable must be replaced.

Insulation Resistance

Insulation Resistance (IR) testing is used to verify the integrity of the heating cable inner and outer jackets. IR testing is analogous to pressure testing a pipe and detects if a hole exists in the jacket.

Circuit Length Verification (Capacitance Test)

The installed circuit length is verified through a capacitance measurement of the XL-Trace Edge heating cable. Compare the calculated installed length against the system design. If the calculated length is shorter than the system design, confirm all connections are secure and the grounding braid is continuous.

6

Commissioning and Preventive Maintenance

Power Check

The power check is used to verify that the system is generating the correct power output. This test can be used in commissioning to confirm that the circuit is functioning correctly. For ongoing maintenance, compare the power output to previous readings.

The heating cable power output per foot is calculated by dividing the total wattage by the total length of a circuit. The current, voltage, operation temperature, and length must be known. Circuit length can be determined from “as built” drawings, meter marks on the heating cable, or with the capacitance test. The watts per foot can be compared to the heating cable output in Figure 28 on page 43 for an indication of heating cable performance.

Ground-Fault Test

Test all ground-fault breakers per manufacturer’s instructions.

7

Test Procedures

7.1 System Tests

The following tests must be done after installing the connection kits, but before the thermal insulation is applied to the pipe:

1. Visual inspection
2. Insulation resistance test

After the thermal insulation has been installed on the pipe, the following tests must be performed:

1. Visual inspection
2. Insulation resistance test
3. Circuit length verification (Capacitance test)
4. Power test
5. Temperature test

All test procedures are described in this manual. It is the installer's responsibility to perform these tests or have an electrician perform them. Record the results in the Installation and Inspection Record in Section 10.

Visual Inspection Test

- Check inside all power, splice, and tee kits for proper installation, overheating, corrosion, moisture, or loose connections.
- Check the electrical connections to ensure that ground and bus wires are insulated over their full length.
- Check for damaged, missing, or wet thermal insulation.
- Check that end seals, splices, and tees are properly labeled on insulation cladding.
- Check the controller for proper setpoint and operation. Refer to its installation and operation manual for details.

Insulation Resistance Test

FREQUENCY

Insulation resistance testing is required during the installation process and as part of regularly scheduled maintenance, as follows:

- Before installing the heating cable

7

Test Procedures

- Before installing connection kits
- Before installing the thermal insulation
- After installing the thermal insulation
- Prior to initial start-up (commissioning)
- As part of the regular system inspection
- After any maintenance or repair work

PROCEDURE

Insulation resistance testing (using a megohmmeter) should be conducted at three voltages: 500, 1000, and **2500 Vdc**. Potential problems may not be detected if testing is done only at 500 and 1000 volts. First measure the resistance between the heating cable bus wires and the braid (Test A), then measure the insulation resistance between the braid and the metal pipe (Test B). Do not allow test leads to touch junction box, which can cause inaccurate readings.



Important: System tests and regular maintenance procedures require that insulation resistance testing be performed. Test directly from the controller or the junction box closest to the power connection.

INSULATION RESISTANCE CRITERIA

A clean, dry, properly installed circuit should measure thousands of megohms, regardless of the heating cable length or measuring voltage (500–2500 Vdc).

All insulation resistance values should be greater than 1000 megohms. If the reading is lower, consult Section 8, Troubleshooting Guide.



Important: Insulation resistance values for Test A and B for any particular circuit should not vary more than 25 percent as a function of measuring voltage. Greater variances may indicate a problem with your heat-tracing system; confirm proper installation and/or contact Chemelex for assistance.

7

Test Procedures

Test A

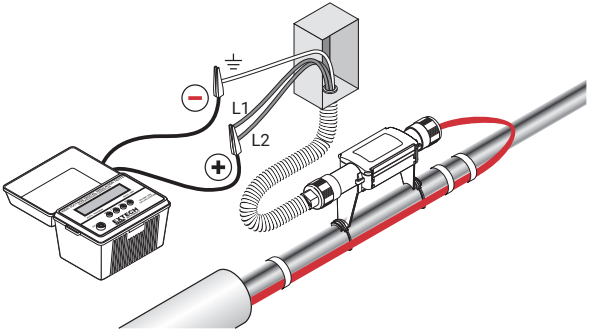

Test B

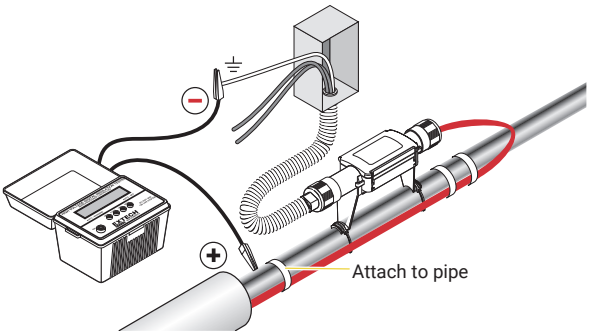

Figure 28: Insulation resistance test

7

Test Procedures

INSULATION RESISTANCE TEST PROCEDURE

1. De-energize the circuit.
2. Disconnect the controller if installed.
3. Disconnect bus wires from terminal block.
4. Set test voltage at 0 Vdc.
5. Connect the negative (-) lead to the heating cable metallic braid or RayClic green wire.
6. Connect the positive (+) lead to both heating cable bus wires or RayClic black wires.
7. Turn on the megohmmeter and set the voltage to 500 Vdc; apply the voltage for one minute. Meter needle should stop moving. Rapid deflection indicates a short. Record the insulation resistance value in the Inspection Record.
8. Repeat Steps 4–7 at 1000 and 2500 Vdc.
9. Turn off the megohmmeter.
10. If the megohmmeter does not self-discharge, discharge phase connection to ground with a suitable grounding rod. Disconnect the megohmmeter.
11. Repeat this test between braid and pipe.
12. Reconnect bus wires to terminal block.
13. Reconnect the temperature controller.

Circuit length verification (capacitance test)

Connect the capacitance meter negative lead to both bus wires and the positive lead to the braid wire. Set the meter to the 200 nF range. Multiply this reading by the capacitance factor for the correct heating cable shown below to determine the total circuit length.

Length (ft or m) = Capacitance (nF) x Capacitance factor (ft/nF or m/nF)

TABLE 9: CAPACITANCE FACTORS

Heating cable	Capacitance factor	
	ft/nF	(m/nF)
3XLE	6.7	(2.1)
5XLE and 8XLE	5.0	(1.6)
12XLE	5.8	(1.8)

Compare the calculated circuit length to the design drawings and circuit breaker sizing tables.

7

Test Procedures



Figure 29: Capacitance test

Power Check

The power output of self-regulating heating cable is temperature-sensitive and requires the following special procedure to determine its value:

1. Power the heating cable and allow it to stabilize for 2 hours, then measure current and voltage at the junction box. If a controller is used, refer to details below.
2. Check the pipe temperature under the thermal insulation at several locations.
3. Calculate the power of the heating cable by multiplying the current by the input voltage and dividing by the actual circuit length.

$$\text{Power (w/ft or m)} = \frac{\text{Volts (Vac)} \times \text{Current (Amps)}}{\text{Length (ft or m)}}$$

The power calculated should be similar to the value generated by:

$$\text{Rated Power (w/ft or m)} = \text{Volts (Vac)} \times \text{Rated Current}$$

7

Test Procedures

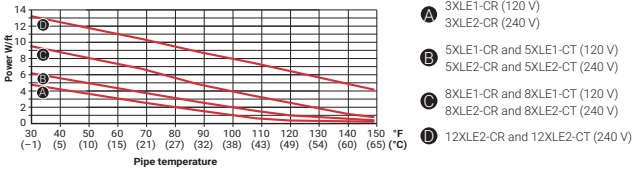

Figure 30: Power output

7.2 Fault Location Tests

There are three methods used for finding a fault within a section of heating cable.

1. Ratio method
2. Conductance method
3. Capacitance method

Ratio Method

The ratio method uses resistance measurements taken at each end of the heating cable to approximate the location of a bus wire short. A shorted heating cable could result in a tripped circuit breaker. If the resistance can be read on a standard ohm meter this method can also be used to find a fault from a bus wire to the ground braid. This type of short would trip a GFPD and show a failed insulation resistance reading. Measure the bus-to-bus heating cable resistance at each end (measurement A and measurement B) of the suspected section.

7

Test Procedures

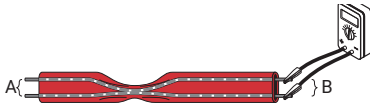

Figure 31: Heating cable resistance measurement test

The approximate location of the fault, expressed as a percentage of the heating cable length from the front end, is:

$$\text{Fault location: } D = \frac{A}{(A + B)} \times 100$$

Example: A = 1.2 ohms
 B = 1.8 ohms

$$\text{Fault location: } D = 1.2 / (1.2 + 1.8) \times 100 \\ = 40\%$$

To locate a low resistance ground fault, measure between bus and braid.



Figure 32: Low resistance ground-fault test

The approximate location of the fault, expressed as a percentage of the heating cable length from the front end, is:

$$\text{Fault location: } D = \frac{A}{(A + B)} \times 100$$

Example: A = 1.2 ohms
 B = 1.8 ohms

$$\text{Fault location: } D = 1.2 / (1.2 + 1.8) \times 100 \\ = 40\%$$

The fault is located 40% into the circuit as measured from the front end.

7

Test Procedures

Conductance Method

The conductance method uses the core resistance of the heating cable to approximate the location of a fault when the heating cable has been severed and the bus wires have not been shorted together. A severed heating cable may result in a cold section of pipe and may not trip the circuit breaker. Measure the bus-to-bus heating cable resistance at each end (measurement A and measurement B) of the suspect section. Since self-regulating heating cables are a parallel resistance, the ratio calculations must be made using the conductance of the heating cable.



Figure 33: Heating cable resistance measurement

The approximate location of the fault, expressed as a percentage of the heating cable length from the front end, is:

$$\text{Fault location: } D = \frac{1/A}{(1/A + 1/B)} \times 100$$

Example: A = 100 ohms
 B = 25 ohms

$$\text{Fault location: } D = (1/100) / (1/100 + 1/25) \times 100 \\ = 20\%$$

The fault is located 20% from the front end of the circuit.

Capacitance Method

This method uses capacitance measurement (nF) as described on Figure 29, to approximate the location of a fault where the heating cable has been severed or a connection kit has not been connected.

Record the capacitance reading from one end of the heating cable. The capacitance reading should be measured between both

7

Test Procedures

bus wires twisted together (positive lead) and the braid (negative lead). Multiply the measured capacitance with the heating cable's capacitance factor as listed in the following example:

Example: 5XLE2-CR = 42.2 nF

Capacitance factor = 5.0 ft/nF

Fault location = 42.2 nF x 5.0 ft/nF = 211 ft (64 m)

The ratio of one capacitance value taken from one end (A) divided by the sum of both A and B (A + B) and then multiplied by 100 yields the distance from the first end, expressed as a percentage of the total heating cable circuit length. See Table 9 on page 43 for capacitance factors.

Fault location: $C = \frac{A}{(A + B)} \times 100$

7

Test Procedures

8

Troubleshooting Guide

Symptom

Probable Causes

Circuit breaker trips

Circuit breaker is undersized

Connections and/or splices are shorting out.

Physical damage to heating cable is causing a direct short.

Bus wires are shorted at the end.

Circuit lengths too long.

Nick or cut exists in heating cable or power feed wire with moisture present or moisture in connections.

GFPD is undersized (5 mA used instead of 30 mA) or miswired.

Low or inconsistent insulation resistance

Nicks or cuts in the heating cable.

Short between the braid and heating cable core or the braid and pipe.

Arcing due to damaged heating-cable insulation.

Moisture present in the connection kits.

Test leads touching the junction box.

8

Troubleshooting Guide

Corrective Action

Recheck the design for startup temperature and current loads. Do not exceed the maximum circuit length for heating cable used. Replace the circuit breaker if defective or improperly sized.

Visually inspect the connection kits. Replace if necessary.

Check for damage around the valves and any area where there may have been maintenance work. Replace damaged sections of heating cable.

Check the end seal to ensure that bus wires are not shorted. If a dead short is found, the heating cable may have been permanently damaged by excessive current and may need to be replaced.

Separate the circuit into multiple circuits that do not exceed maximum circuit lengths.

Replace the heating cable, as necessary. Dry out and reseal the connection and splices. Using a megohmmeter, retest insulation resistance.

Replace undersized GFPD with 30-mA GFPD. Check the GFPD wiring instructions

If heating cable is not yet insulated, visually inspect the entire length for damage, especially at elbows in flanges and around valves. If the system is insulated, remove the connection kits one-by-one to isolate the damaged section.

Replace damaged heating-cable sections.

If moisture is present, dry out the connections and retest. Be sure all conduit entries are sealed, and that condensate in conduit cannot enter power connection boxes. If heating-cable core or bus wires are exposed to large quantities of water, replace the heating cable. (Drying the heating cable is not sufficient, as the power output of the heating cable can be significantly reduced.)

Clear the test leads from junction box and restart.

9

Appendix

TABLE A1 MAXIMUM CIRCUIT LENGTH IN FEET

Start-up temperature (°F)	CB size (A)	3XLE1	5XLE1	8XLE1	3XLE2		
		120 V	120 V	120 V	208 V	240 V	277 V
-20°F	15	134	96	75	258	250	247
	20	179	129	100	344	334	329
	30	269	193	150	517	501	494
	40	335	207	151	689	668	644
0°F	15	156	112	84	307	298	294
	20	209	149	113	410	397	392
	30	313	223	169	615	596	587
	40	368	245	173	696	732	708
20°F	15	189	132	98	376	365	359
	20	252	176	131	501	486	479
	30	368	264	196	696	729	718
	40	368	287	205	696	732	776
40°F	15	242	160	117	492	478	471
	20	323	214	156	656	637	628
	30	368	287	223	696	732	776
	40	368	287	223	696	732	776
50°F	15	-	-	-	-	-	-
	20	-	-	-	-	-	-
	30	-	-	-	-	-	-
	40	-	-	-	-	-	-
65°F	15	-	-	-	-	-	-
	20	-	-	-	-	-	-
	30	-	-	-	-	-	-
	40	-	-	-	-	-	-

* When circuit breaker sizing is listed in:

- black type, the value is for applications with a 40°F maintain
- red type, the value is for applications with a 110°F maintain

9

Appendix

Application 40°F/110°F Maintain*

Circuit breaker sizing (ft)

5XLE2			8XLE2			12XLE2		
208 V	240 V	277 V	208 V	240 V	277 V	208 V	240 V	277 V
201	209	221	138	116	99	127	129	130
268	279	294	210	180	148	169	171	174
402	419	441	316	341	370	253	257	260
469	474	487	339	359	384	338	343	347
227	237	250	170	142	120	129	131	133
303	316	333	236	239	190	172	175	177
455	474	499	354	382	414	258	262	265
535	544	558	384	407	435	340/344	349	354
262	273	288	200	185	154	144	146	148
349	364	383	267	288	276	192	194	197
523	546	575	400	432	469	287	292	296
535	584	642	407/442	452/467	499	340/383	360/389	380/394
311	324	342	232	250	221	162	165	167
414	432	456	309	334	362	216	219	222
535	584	642	407/464	452/500	504/543	324	329	333
535	584	642	407/526	452/555	504/591	340/430	360/439	380/444
-	-	-	253	273	296	173	176	178
-	-	-	337	364	395	231	234	237
-	-	-	506	546	592	346	352	356
-	-	-	586	617	656	430	460	475
-	-	-	296	319	347	192	195	197
-	-	-	395	426	462	256	260	263
-	-	-	592	639	693	384	390	395
-	-	-	686	756	801	430	460	490

9

Appendix

TABLE A2 MAXIMUM CIRCUIT LENGTH IN METERS

Start-up temperature (°C)	CB size (A)	3XLE1	5XLE1	8XLE1	3XLE2		
		120 V	120 V	120 V	208 V	240 V	277 V
-29°C	15	41	29	23	79	76	75
	20	55	39	30	105	102	100
	30	82	59	46	158	153	151
	40	102	63	46	210	204	196
-18°C	15	48	34	26	94	91	90
	20	64	45	34	125	121	120
	30	95	68	52	188	182	179
	40	112	75	53	212	223	216
-7°C	15	58	40	30	115	111	109
	20	77	54	40	153	148	146
	30	112	80	60	212	222	219
	40	112	88	63	212	223	237
4°C	15	74	49	36	150	146	144
	20	98	65	48	200	194	191
	30	112	88	68	212	223	237
	40	112	88	68	212	223	237
10°C	15	-	-	-	-	-	-
	20	-	-	-	-	-	-
	30	-	-	-	-	-	-
	40	-	-	-	-	-	-
18°C	15	-	-	-	-	-	-
	20	-	-	-	-	-	-
	30	-	-	-	-	-	-
	40	-	-	-	-	-	-

* When circuit breaker sizing is listed in:

- black type, the value is for applications with a 4°C maintain
- **red** type, the value is for applications with a 43°C maintain

9

Appendix

Application 4°C/43°C Maintain*

Circuit breaker sizing (fm)

5XLE2			8XLE2			12XLE2		
208 V	240 V	277 V	208 V	240 V	277 V	208 V	240 V	277 V
61	64	67	42	35	30	39	39	40
82	85	90	64	55	45	52	52	53
123	128	134	96	104	113	77	78	79
143	145	148	103	109	117	103	105	106
69	72	76	52	43	37	39	40	41
92	96	102	72	73	58	52	53	54
139	145	152	108	116	126	79	80	81
163	166	170	117	124	133	104/105	106	108
80	83	88	61	56	47	44	45	45
106	111	117	81	88	84	59	59	60
159	166	175	122	132	143	88	89	90
163	178	196	124/135	138/142	152	104/117	110/119	116/120
95	99	104	71	76	67	49	50	51
126	132	139	94	102	110	66	67	68
163	178	196	124/160	138/169	154/180	99	100	102
163	178	196	124/160	138/169	154/180	104/131	110/134	116/135
-	-	-	77	83	90	53	54	54
-	-	-	103	111	120	70	71	72
-	-	-	154	166	180	105	107	109
-	-	-	179	188	200	131	140	145
-	-	-	90	97	106	59	59	60
-	-	-	120	130	141	78	79	80
-	-	-	180	195	211	117	119	120
-	-	-	209	230	244	131	140	149

9

Appendix

TABLE A3 TRANSFORMER SIZING (AMPERES/FOOT)

Minimum start-up temperature (°F)	3XLE1	5XLE1	8XLE1	3XLE2		
	120 V	120 V	120 V	208 V	240 V	277 V
-20	0.089	0.124	0.16	0.046	0.048	0.049
0	0.077	0.107	0.142	0.039	0.040	0.041
20	0.064	0.091	0.122	0.032	0.033	0.033
40	0.050	0.075	0.102	0.024	0.025	0.025
50	-	-	-	-	-	-
65	-	-	-	-	-	-

TABLE A4 TRANSFORMER SIZING (AMPERES/METER)

Minimum start-up temperature (°C)	3XLE1	5XLE1	8XLE1	3XLE2		
	120 V	120 V	120 V	208 V	240 V	277 V
-29	0.292	0.407	0.525	0.151	0.157	0.161
-18	0.253	0.351	0.466	0.128	0.131	0.134
-7	0.210	0.298	0.400	0.105	0.108	0.108
4	0.164	0.246	0.335	0.079	0.082	0.082
10	-	-	-	-	-	-
18	-	-	-	-	-	-

9

Appendix

5XLE2			8XLE2			12XLE2		
208 V	240 V	277 V	208 V	240 V	277 V	208 V	240 V	277 V
0.06	0.057	0.054	0.076	0.07	0.065	0.095	0.093	0.092
0.053	0.051	0.048	0.068	0.063	0.058	0.093	0.092	0.09
0.046	0.044	0.042	0.06	0.056	0.051	0.084	0.082	0.081
0.039	0.037	0.035	0.052	0.048	0.044	0.074	0.073	0.072
-	-	-	0.052	0.048	0.044	0.074	0.073	0.072
-	-	-	0.052	0.048	0.044	0.074	0.073	0.072

5XLE2			8XLE2			12XLE2		
208 V	240 V	277 V	208 V	240 V	277 V	208 V	240 V	277 V
0.197	0.187	0.177	0.249	0.230	0.213	0.312	0.305	0.302
0.174	0.167	0.157	0.223	0.207	0.190	0.305	0.302	0.295
0.151	0.144	0.138	0.197	0.184	0.167	0.276	0.269	0.266
0.128	0.121	0.115	0.171	0.157	0.144	0.243	0.239	0.236
-	-	-	0.171	0.157	0.144	0.243	0.239	0.236
-	-	-	0.171	0.157	0.144	0.243	0.239	0.236

10

Installation and Inspection Record

Installation and Inspection Record

Facility

Test Date:

Circuit number:

Heating cable type:

Controllers:

Temperature setting:

Circuit length:

Commission

Inspection date:

Visual inspection

Confirm 30-mA ground-fault device (proper rating/function)

Visual inspection inside connection boxes for overheating, corrosion, moisture, and other problems.

Proper electrical connection, ground, and bus wires insulated over full length

Damaged or missing thermal insulation; damaged, missing, cracked lagging or weatherproofing.

Covered end seals, splices, and tees properly labeled on insulation.

Check controllers for moisture, corrosion, setpoint, switch operation.

Insulation resistance test

M-Ohms

Bus to braid (Test A)

500 Vdc

1000 Vdc

2500 Vdc

Braid to pipe (Test B)

500 Vdc

1000 Vdc

2500 Vdc

Circuit length verification

Capacitance test: Circuit length (ft) = Capacitance (nF) x Capacitance factor (x 3.28 = m)

Power check

Circuit voltage

Panel

(Vac)

Circuit amps after 2 hours

(Amps)

Pipe temperature

(°F) (°C)

Power = (volts x amps after 2 hrs) / circuit length (watts/ft) (watts/m)

North America

Tel +1 800 545 6258
info@chemelex.com

Latin America

Tel +1 713 868 4800
info@chemelex.com

Europe, Middle East, Africa, India

Tel +32 16 213 511
Fax +32 16 213 604
info@chemelex.com

Asia Pacific

Tel +86 21 2412 1688
infoAPAC@chemelex.com

chemelex
excellence is everything

chemelex.com

Raychem Tracer Pyrotenax Nuheat

©2026 Chemelex. All Chemelex marks and logos are owned or licensed by Chemelex Europe GmbH or its affiliates. All other trademarks are the property of their respective owners. Chemelex reserves the right to change specifications without notice.

RAYCHEM-IM-H58033-XLTraceEdgePFP-EN-2602