

Raychem

NGC-40-HTC & NGC-40-HTC3

Control and Monitoring Modules for use with Raychem NGC-40 System
Installation Instructions

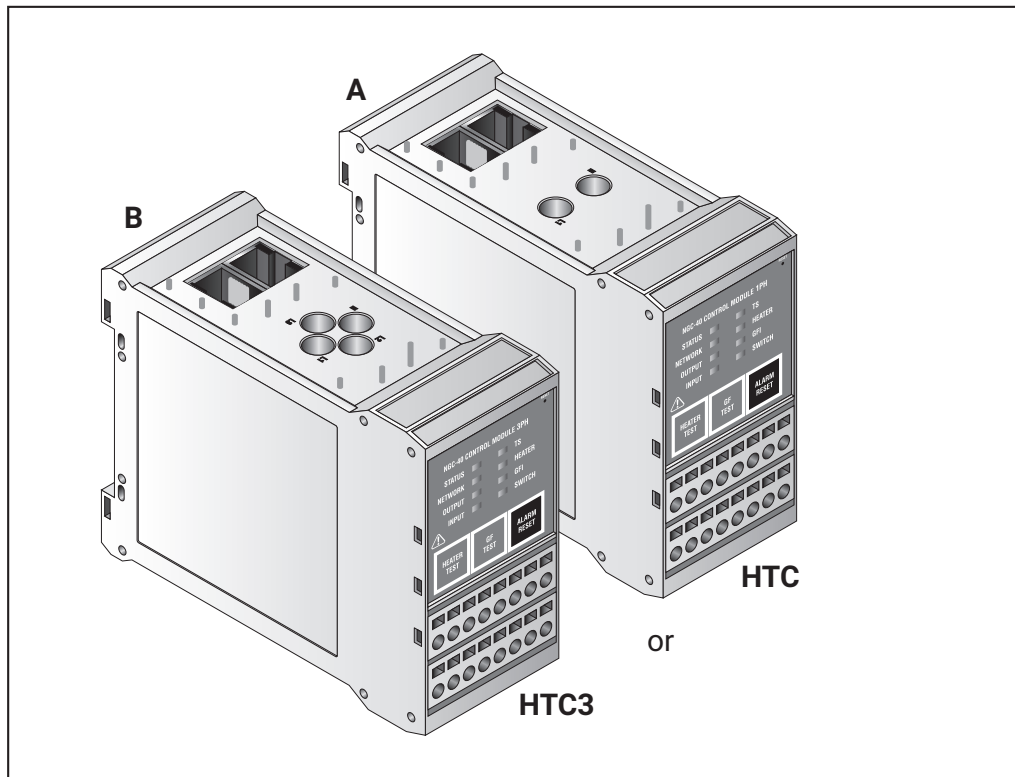

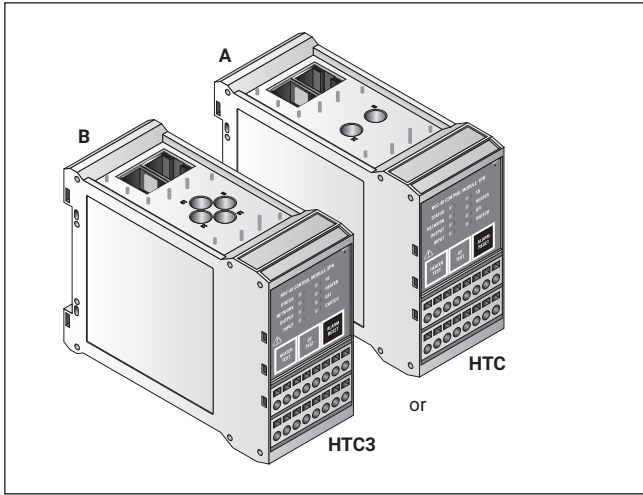

APPROVALS AND CERTIFICATIONS

Hazardous Locations



Class I, Div. 2, Groups A,B,C,D T4
 Class I, Zone 2, AEx ec nC IIC T4 Gc IP20
 Ex ec nC IIC T4 Gc X
 $-40^{\circ}\text{C} \leq T_a \leq +65^{\circ}\text{C}$

Conforms to:

UL STD 121201, 60079-0,
 60079-7, 60079-15, 61010-1, 61010-2-201

Certified to:

CSA STD C22.2# 213, 60079-0, 60079-7,
 60079-15, 61010-1, 61010-2-201

IEC Ex Markings:

IEC Ex ETL17.0062X
 Ex ec nC IIC T4 Gc

ATEX Markings:

ITS17ATEX402833X
 Ex II 3 G Ex ec nC IIC T4 Gc



DESCRIPTION

The Raychem NGC-40-HTC (for single-phase heaters) and NGC-40-HTC3 (for three-phase heaters) modules are used to control either an external solid-state relay or a contactor within the NGC-40 control and monitoring system. These modules also have one alarm output and one digital input. The alarm output can be used to activate an external annunciator. The digital input is programmable and may be used for various functions such as forcing outputs on and off. Other features include ground-fault and line current sensing for both HTC and HTC3. The front panel of the HTC modules has LED indicators for various status conditions. The front panel also provides a ground-fault and heater test button.

TOOLS REQUIRED

- Small flat-blade screwdriver

ADDITIONAL MATERIALS

- Power supply 24 Vdc @100 mA per NGC-40-HTC/HTC3
- Custom built CAN cables with RJ-45 connections
- CAN Termination Resistor
- Custom built CAN cables with RJ-45 connections
- CAN Termination Resistor

KIT CONTENTS

Item	Qty	Description
A	1	NGC-40-HTC module (single-phase heaters)
or		
B	1	NGC-40-HTC3 module (three-phase heaters)

Special conditions of use:

- The overall equipment is evaluated to type of protection "ec". Sealed devices in the form of relays are additionally present in module NGC-40-HTC and NGC-40-HTC3 and comply with requirements for the type of protection nC.
- For full connection details see these installation instructions.
- The equipment shall only be used in an area of not more than pollution degree 2, as defined in IEC/EN 60664-1.
- The equipment shall be installed in an enclosure that provides a minimum ingress protection of IP54 in accordance with IEC/EN 60079-0.
- Transient protection shall be provided that is set at a level not exceeding 140% of the peak rated voltage value at the supply terminals to the equipment.

⚠ WARNING:

This component is an electrical device that must be installed correctly to ensure proper operation and to prevent shock or fire. For technical support, call Chemelex at (800) 545-6258.

GENERAL

Supply voltage	24 Vdc \pm 10%
Internal power consumption	<2.4 W per NGC-40-HTC/HTC3 module
Ambient operating temperature	-40°C to 65°C (-40°F to 149°F)
Ambient storage temperature	-55°C to 75°C (-67°F to 167°F)
Environment	PD2, CAT III
Max. altitude	2,000 m (6,562 ft)
Humidity	5 – 90% noncondensing
Mounting	Din Rail – 35 mm

ELECTROMAGNETIC COMPATIBILITY

Emissions	EN 61000-6-3 Emission standard for residential, commercial and light industrial environments
Immunity	EN 61000-6-2 Immunity standard for industrial environments

TEMPERATURE SENSORS

Type	100 Ω platinum RTD, 3-wire, α = 0.00385 ohms/ohm/°C Can be extended with a 3-conductor shielded cable of 20 Ω maximum per conductor 100 Ω , Ni-Fe, 2-wire Can be extended with a 2-wire shielded cable of 20 Ω maximum per conductor
Quantity	One per NGC-40-HTC/HTC3 module

ALARM RELAY

Dry contact relay (voltage free)	Relay contact rated 250 V / 3 A 50/60 Hz (EC) and 277 V / 3 A 50/60 Hz (cCSAus). Alarm relay is programmable. NO and NC contacts available.
----------------------------------	---

CONTACTOR OUTPUT RELAY

	Relay contact rated 250 V / 3 A 50/60 Hz (CE) and 277 V / 3 A 50/60 Hz (c-CSA-us).
--	--

DIGITAL INPUT

Multi-purpose input	Multi-purpose input for connection to external dry (voltage-free) contact or DC voltage. May be user programmable for: not used / force off / force on functions. It can be configured to be active open or active closed.
---------------------	--

CAN NETWORKING PORT

Type	2-wire isolated CAN-based peer to peer network. Isolated to 24 Vdc – verified by 500 Vrms dielectric withstand test
Connection	Two 8-pin RJ-45 connectors (both may be used for Input or Output connections)
Protocol	Proprietary NGC-40
Topology	Daisy chain
Cable length	10 m (33 ft) maximum
Quantity	Up to 80 HTC/HTC3 and IO modules per network segment
Address	Unique, factory assigned

CONNECTION TERMINALS

Wiring terminals Cage clamp, 0.5 to 2.5 mm² (24 to 12 AWG)

HOUSING

Size 45.1 mm (1.78 in) wide x 87 mm (3.43 in) high x 106.4 mm (4.2 in) deep

LINE CURRENT SENSORS

Max current 63 A

Accuracy ± 2% of reading

GROUND-FAULT SENSOR

Range 10 – 250 mA

Accuracy ± 2% of range

OUTPUTS

SSR output 12 Vdc @ 45 mA max per output

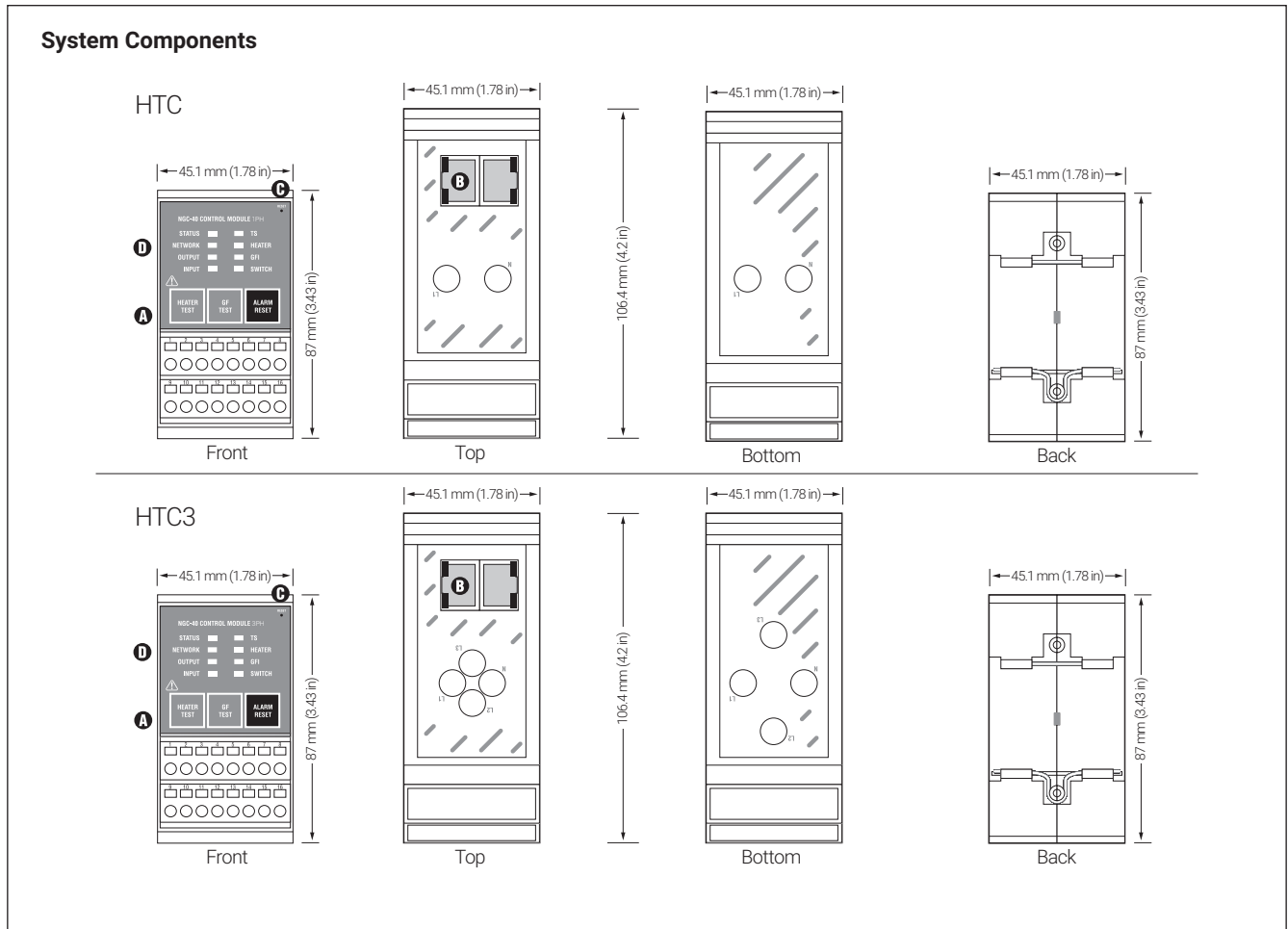

System Components (Continued)

A. Wiring terminals

Terminals	Function
1	⚠ Alarm relay N.O.
2	⚠ Alarm relay COM
3	⚠ Alarm relay N.C.
4	Not used
5	SSR Out +
6	SSR Out -
7	Digital In +
8	Digital In -
9	⚠ Line In
10	⚠ Line Out
11	⚠ Coil Out
12	
13	TS COM (Wht)
14	TS Sense (Red)
15	TS Source (Red)
16	Not used

⚠ **WARNING:** Shock Hazard. Disconnect from live voltage prior to accessing terminals

B. CAN bus/Module power

C. RESET

D. STATUS LEDS

Status: Indicates status of HTC/HTC3 module	
Off	No power
Green	Normal operation, no internal faults
Yellow	In Factory mode
Red	HTC/HTC3 operating status
Flash R	Internal Fault:
Flash R/G	Factory status
Flash R/Y	Internal fault detected
Network: Indicates CAN network activity	
Off	No network activity
Green	Flicker on receipt of network data
Yellow	Flicker on transmission of network data
Flash R	Network communication failure
Input: Shows status of digital input	
Off	Input is inactive (open)
Green	Input is active (shorted)
Flash R	Ext. input source failure
Output: Shows status of contactor or SSR	
Off	Output off
Green	Follows output state

Heater: Indicates the heater's alarm status

Off	No alarm
Red	High or low current or resistance alarm
Flash R	Overcurrent trip alarm

TS: Indicates the temperature alarm status

Off	No alarm
Red	High or low temperature alarm
Flash R	Temperature sensor failure

GFI: Indicates ground-fault status

Off	No alarm
Red	High or low ground-fault alarm
Flash R	Ground-fault trip alarm

Switch: Indicates contactor/SSR switch status

Off	No alarm
Red	Contactor cycle count alarm
Flash R	Switch failed shorted on

Mounting the NGC-40-HTC/HTC3

Each NGC-40-HTC/HTC3 mounts on a DIN 35 rail.

MOUNTING: Insert the rear bottom of the module into the DIN rail, then push up and inwards to engage the clip.

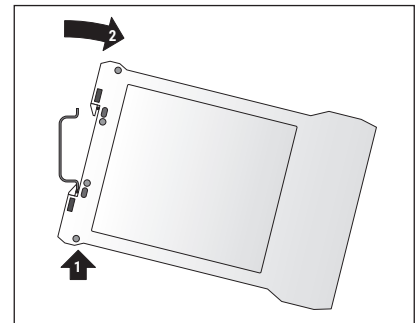
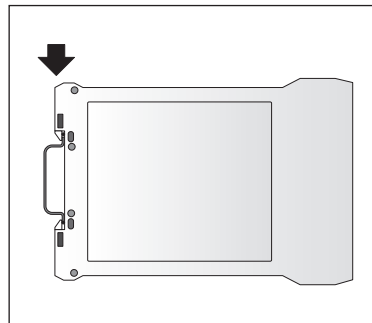
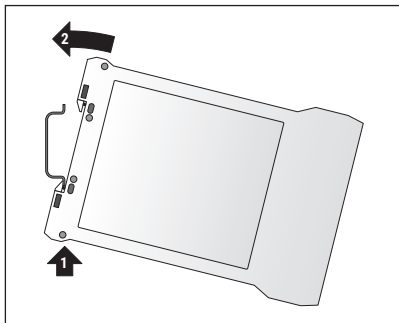

REMOVAL: Push the module upwards to disengage the clip, then rotate the module toward you.

Power Supply/CAN

The power supply/CAN connector is an RJ-45 connector.
The CAN termination device must be installed in the unused port of the last module.

Connections are the same for the HTC3.

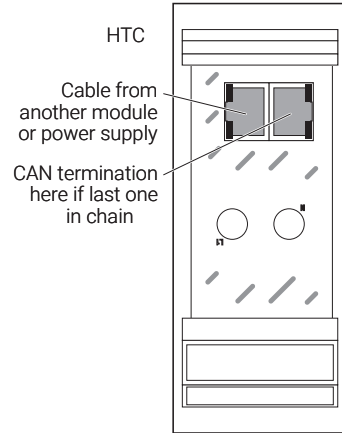

RTD Input Connections – North American Installation Technique

For all RTD terminations, the RTD field wires must be terminated on a panel-mounted terminal block.

Connections are the same for the HTC3.

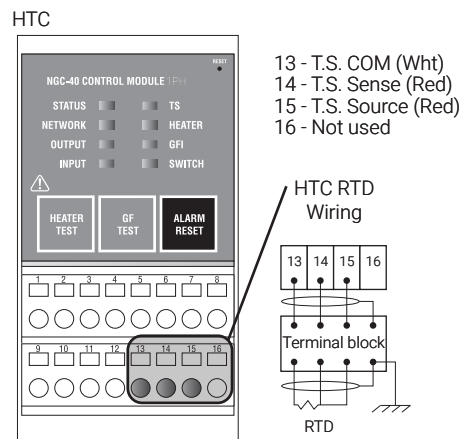

RTD Input Connections – European Installation Technique

For all RTD terminations, the RTD field wires must be terminated on a panel-mounted terminal block. The RTD cable shield from the field terminal block to the HTC module should be terminated at the earth ground bar located near the module.

Connections are the same for the HTC3.

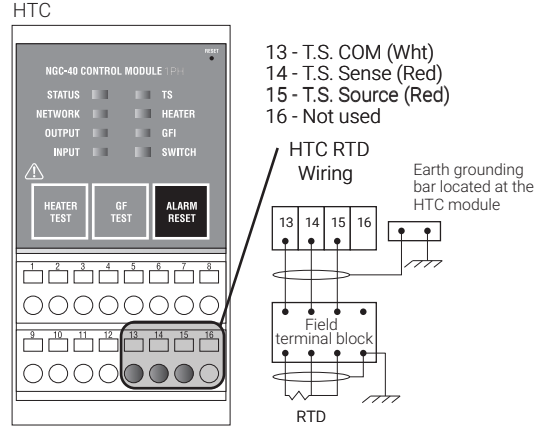

Power Supply/CAN

Terminals 9 and 11 switch voltage to the contactor coils. The internal pilot relay will switch the supply voltage (up to 277 V) to the contactor coil. Refer to the diagram at the end of this document called "NGC-40 CAN bus Connections for Up to 10 Modules" for detail wiring.

Note: Exposure to some chemicals may degrade the sealing properties of the relay output, manufactured by NAIS, PN JQ1P-12V. Periodically inspect the relay output for degradation of properties and replace if any degradation is found.

Connections are the same for the HTC3.

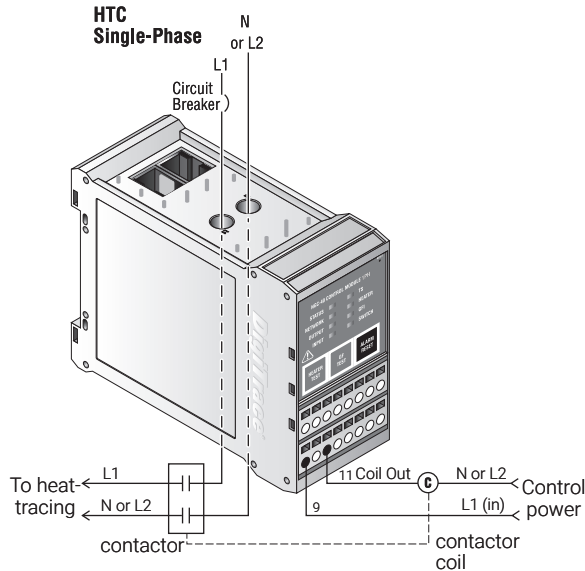

WARNING: Shock Hazard. Disconnect from live voltage prior to accessing terminals.

HTC3 Relay Output to Contactor - Three-Phase

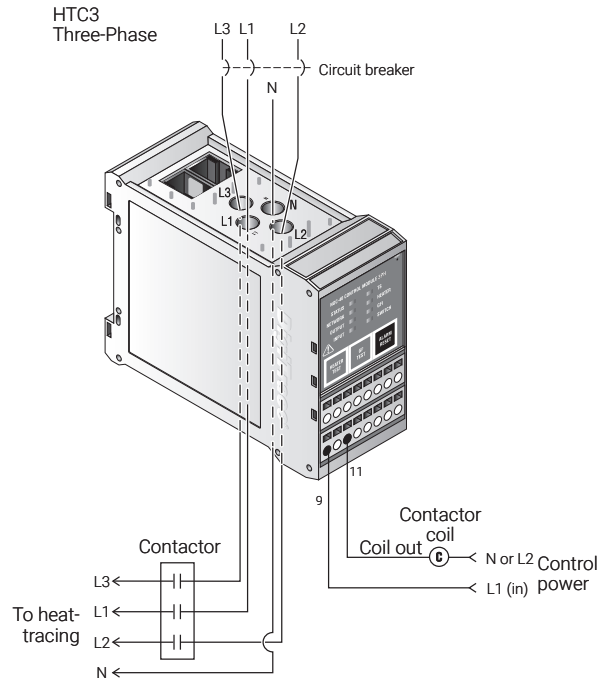

WARNING: Shock Hazard. Disconnect from live voltage prior to accessing terminals.

HTC Output Connections to SSR - Single-Phase

Terminals 5 & 6 switch voltage to the SSR. The internal SSR driver will switch the internal supply voltage (12 Vdc) to the SSR.

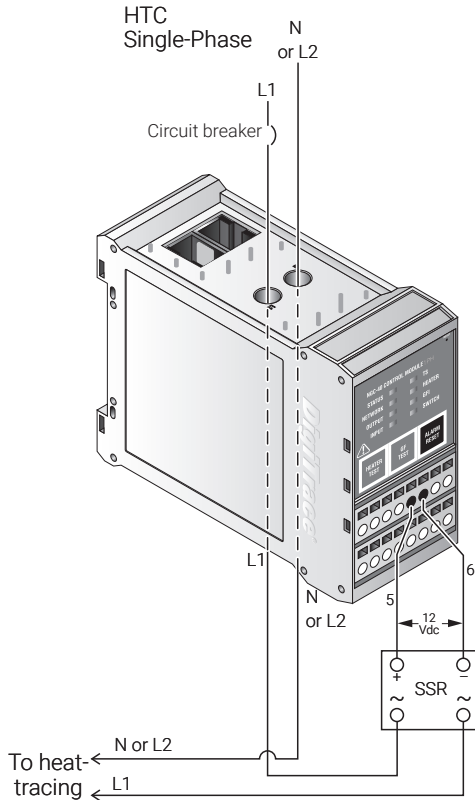

HTC3 Output Connections to SSR - Three-Phase

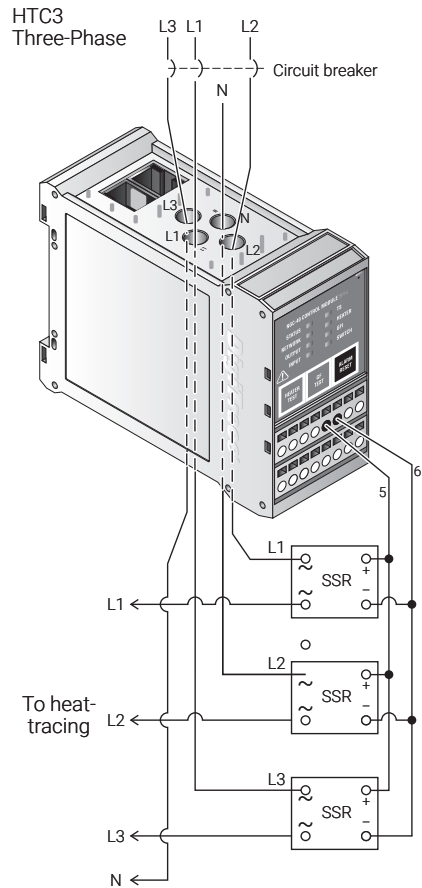

WARNING: Shock Hazard. Disconnect from live voltage prior to accessing terminals.

Alarm

WARNING: Shock Hazard. Disconnect from live voltage prior to accessing terminals.

Note: Exposure to some chemicals may degrade the sealing properties of the alarm relay, manufactured by NAIS, PN JQ1P-12V. Periodically inspect the alarm relay for degradation of properties and replace if any degradation is found.

Multi-purpose. Alarm relay energized in normal state.

The alarm relay is configured as Fail Safe.

The alarm relay connections provide a form C dry contact, rated at 277 V max (3 A).

The NO (normally open) contact is open in non-energized condition. When energized, it closes during normal conditions and will open upon an alarm condition or power failure.

The NC (normally closed) contact is closed in non-energized condition. When energized, it opens during normal conditions and will close upon an alarm condition or power failure.

Relay contact rated

250 V / 3A 50/60 Hz (CE)

277 V / 3A 50/60 Hz (c-CSA-us)

Connections are the same for the HTC3.

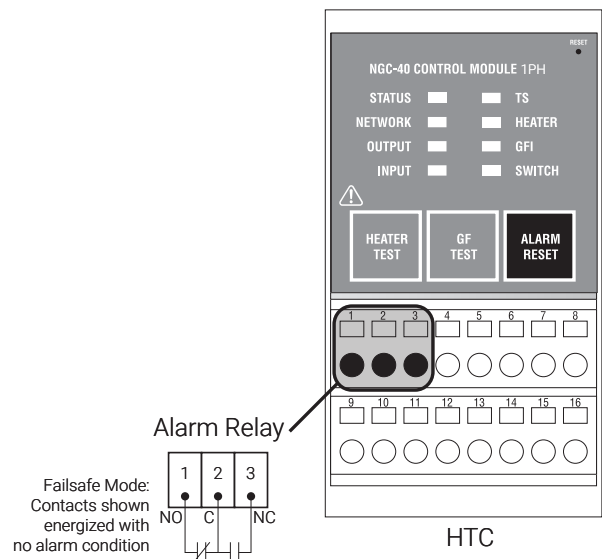

Digital Input Connections – North American and European Installation Techniques

Digital Input Multi-purpose input for connection to external dry (voltage free) contact or DC voltage.
 Rating 100 Ω max loop resistance or 5-24 Vdc @ 1 mA maximum

Connections are the same for the HTC3.

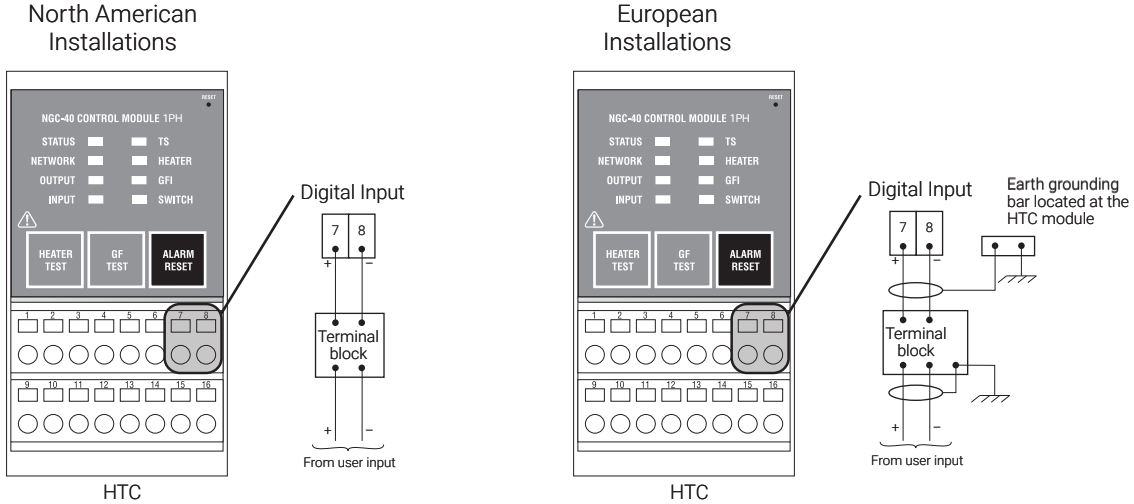

Provide Suitable Panel Enclosure and Determine Locations for NGC-40-HTC or NGC-40-HTC3 Assembly in Panel*

1. Provide suitable panel enclosure

The NGC-40-HTC or NGC-40-HTC3 must be mounted in an enclosure to protect its electronic components. For indoor applications, use a minimum NEMA 1 enclosure (NEMA 12 recommended). For outdoor applications, use a NEMA 4 or NEMA 4X enclosure depending on the requirements.

Note: The Raychem NGC-40-HTC or NGC-40-HTC3 is designed for operation in ambient temperatures from -40°C to 65°C (-40°F to 149°F). If the ambient temperature is outside this range, a space heater and/or cooling fan will be required in the panel.

2. Determine locations for the NGC-40-HTC or NGC-40-HTC3 assembly in the electrical panel.

The NGC-40-HTC or NGC-40-HTC3 should be located in the rear of the panel. The NGC-40-HTC or NGC-40-HTC3 assembly is an electronic unit and must not be located where it will be exposed to strong magnetic fields or excessive vibration.

* North American panel installation techniques

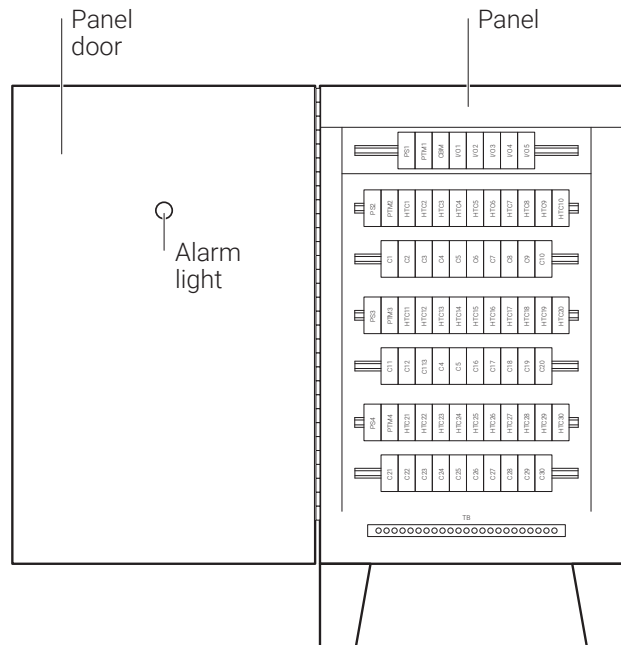

NGC-40 CAN Bus Connections for Up to 10 Modules

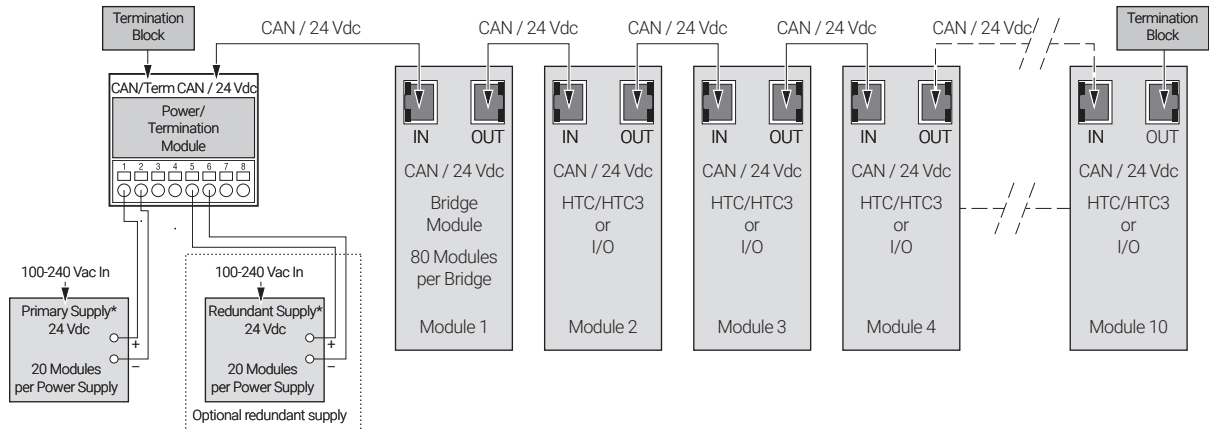

* Power supply shall have a means for disconnect from line voltage

NGC-40 CAN Bus Connections for Up to 20 Modules

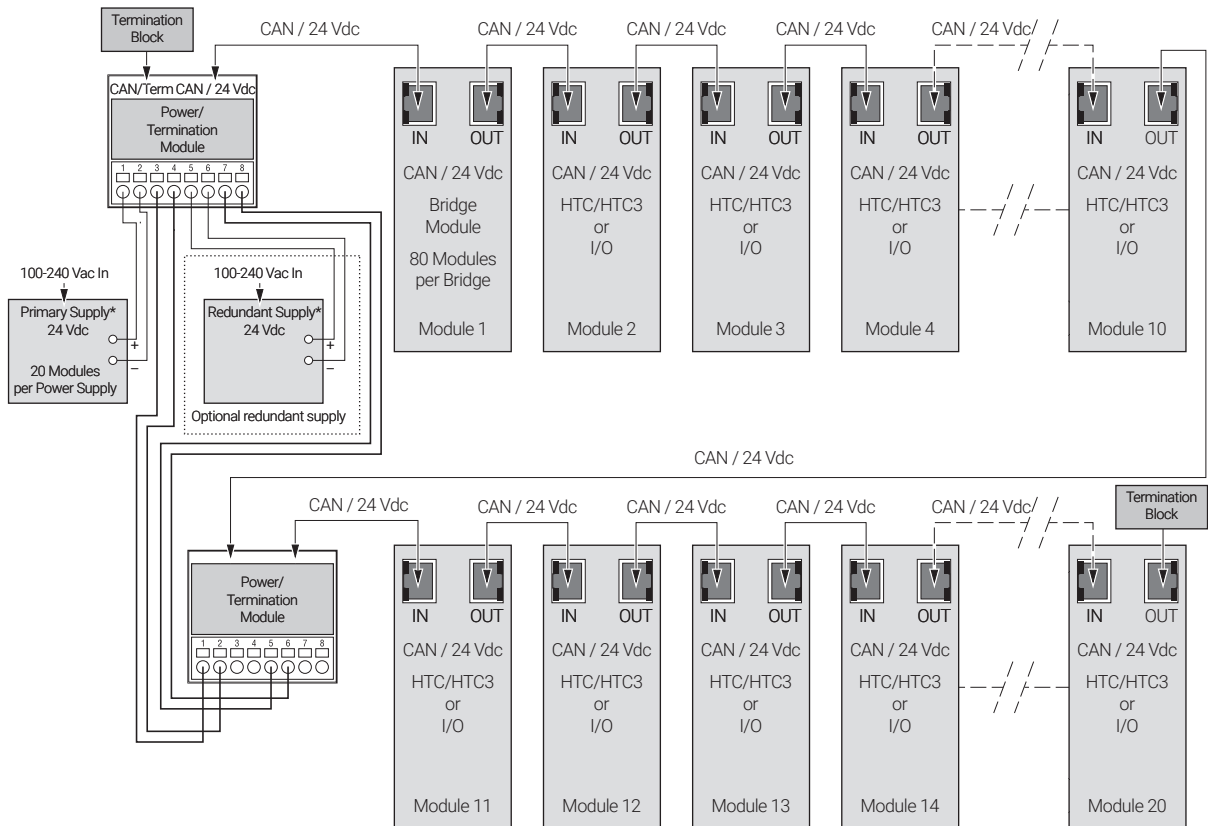

* Power supply shall have a means for disconnect from line voltage

NGC-40 CAN Bus Connections for Up to 40 Modules

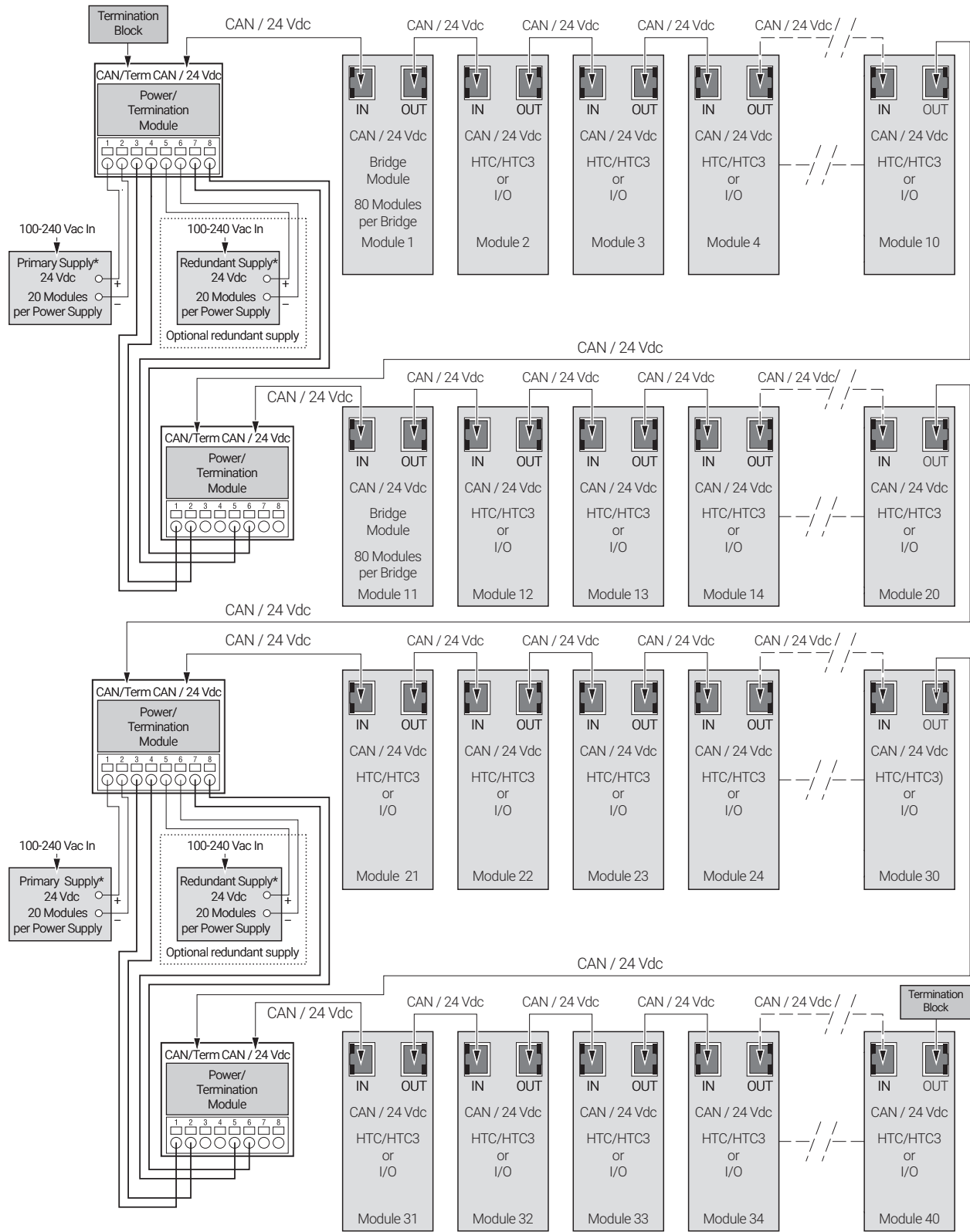

* Power supply shall have a means for disconnect from line voltage

Servicing

The NGC-40-HTC/HTC3 contains no user serviceable parts. Contact your Chemelex representative for service and an RMA number if required.

⚠ WARNING: Explosion Hazard - Substitution of components may impair suitability for Class I, Division 2 hazardous and nonhazardous locations

⚠ WARNING: Explosion Hazard - Do not replace NGC-40-PTM unless power has been switched off or the area is known to be nonhazardous

⚠ WARNING: Explosion Hazard - Do not disconnect equipment unless power has been switched off or the area is known to be nonhazardous

⚠ AVERTISSEMENT - Risque D'explosion - La substitution de composants peut rendre ce matériel inacceptable pour les emplacements de Classe I, Division 2

⚠ AVERTISSEMENT - Risque D'explosion - Couper le courant ou s'assurer que l'emplacement est désigné non dangereux avant de remplacer le NGC-40-PTM

⚠ AVERTISSEMENT - Risque D'explosion - Avant de déconnecter l'équipement, couper le courant ou s'assurer que l'emplacement est désigné non dangereux

North America

Tel +1 800 545 6258
info@chemelex.com

Latin America

Tel +1 713 868 4800
info@chemelex.com

Europe, Middle East, Africa, India

Tel +32 16 213 511
Fax +32 16 213 604
info@chemelex.com

Asia Pacific

Tel +86 21 2412 1688
infoAPAC@chemelex.com

chemelex
excellence is everything

Raychem Tracer Pyrotenax Nuheat