

Raychem

NGC UIT2-HAZ to
UIT3-EX

Conversion Instructions

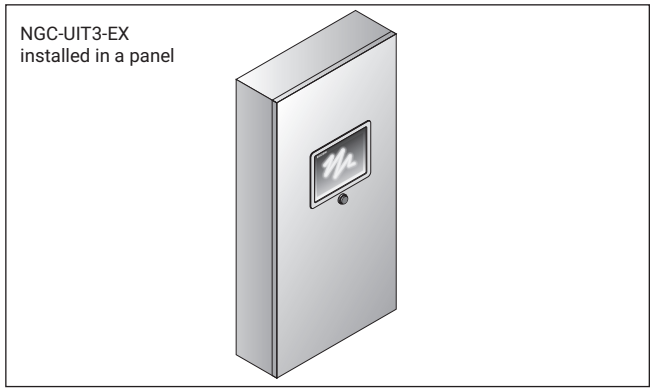

CERTIFICATIONS / APPROVALS

- TYPE 4X, IP65 protection on front panel
- FCC Part15 Subpart B/ICES 003 Class A
- CE marking
 - Low Voltage Directive (2014/35/EU) EN 62368-1:2014 / A11:2017
 - EMC Directive (2014/30/EU) EN 55032:2015 EN 55035:2017
- Conforms to UL 62368-1, 2nd Ed, 2014-12-01; CAN/CSA C22.2 No. 62368-1-14, 2nd Ed, Issued: 2014-12-01; UL 60950-1, 2nd Edition, 2019-05-09 ; CAN/CSA C22.2 No. 60950-1-07, 2nd Edition, 2014-10
- ATEX Directive (2014/34/EU)
 - EN 60079-0:2017
 - EN 60079-11:2012
 - EN 60079-7: 2015 +A1:2018
- IECEx
 - IEC 60079-0 2017
 - IEC 60079-11 2012
 - IEC 60079-7, 5.1 Ed



II 3 G Ex ic ec IIC T5 Gc



Refer to the Raychem NGC-UIT3-EX installation manual for full specifications.

⚠ WARNING:

Do not connect/disconnect equipment unless power has been switched off or the area is known to be non-hazardous.

Ne débranchez pas l'équipement tant que l'alimentation est coupée ou que la zone est connue pour être non dangereux.

⚠ IMPORTANT:

- Use appropriately classified and listed Power Supply (Limited Power Source, or LPS). Follow all applicable wiring codes and regulations.
- Peripheral equipment must be suitable for the location in which it is used.
- There are no non-incendive circuits or non-incendive field wiring within or associated with the unit.
- Only technically qualified service personnel are permitted to install or service the equipment.
- Do not disassemble the system - no user-serviceable parts inside.
- Do not operate the equipment if it has been damaged.
- Utilisez une source d'alimentation correctement classée et répertoriée (source dénergie limitée ou LPS). Suivez tous les codes et normes de câblage applicables.
- L'équipement périphérique doit être adapté à l'emplacement dans lequel il est utilisé.
- Il n'y a pas de circuits non incendiaires ni de câbles de terrain non incendiaires à l'intérieur ou associés avec l'équipement.
- Seul le personnel qualifié est autorisé à installer ou à entretenir l'équipement.
- Ne pas démonter le système - aucune pièce interne ne peut être réparée par l'utilisateur.
- N'utilisez pas l'équipement s'il a été endommagé.

DESCRIPTION

These instructions will guide the experienced installer in converting an existing Raychem NGC-UIT2-HAZ installation to an Raychem NGC-UIT3-EX installation.

TOOLS REQUIRED

- $\frac{5}{16}$ in (8 mm) nut driver
- $\frac{3}{8}$ in (10 mm) nut driver

KIT CONTENTS

Qty	Description	Manufacturer	Manufacturer Part Number
3	Alarm Relay Sockets	Square D	8501RSD34V51
3	12V SPDT Alarm Relays	Square D	NR45B
1	NGC-UIT3-EX	Chemelex	10332-034
12	$\frac{5}{32}$ in KEP nuts		10332-013
1	UIT2-HAZ to UIT3-EX Adapter Plate	Chemelex	T1213129
1	UIT2-HAZ to UIT3-EX Gasket	Chemelex	T1213130
4	Terminal Block	Phoenix Contact	3031364
2	Grounding Terminal Block	Phoenix Contact	3031380
2	End Cover	Phoenix Contact	3030420
1	15' Shielded Twisted Pair RS-485 wire		T0000929

NGC-UIT3-EX CONNECTION DIAGRAM

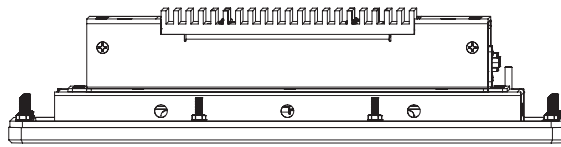

Top view

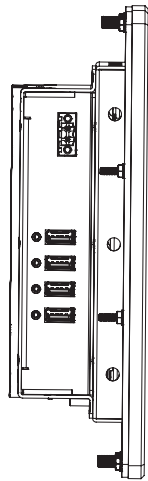

Side view

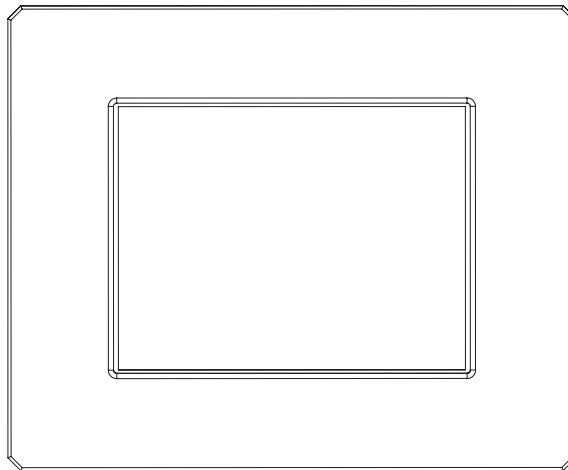

Front view

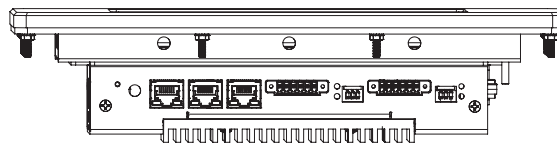

Bottom view

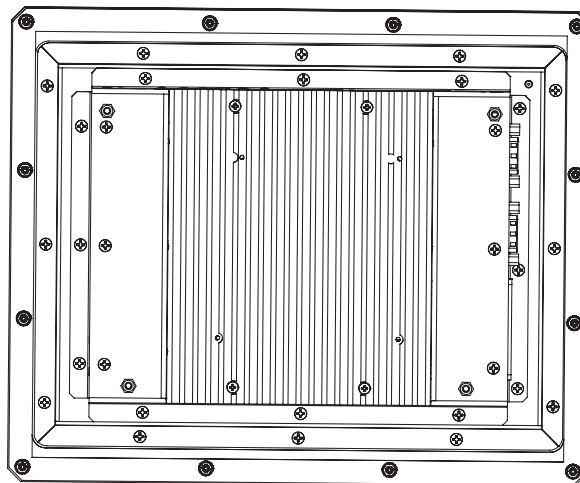

Back view

REMOVING THE NGC-UIT2-HAZ AND RELATED COMPONENTS

1. Prior to removing the existing UIT2-HAZ from the panel door, disconnect the AC power and remove the power cord. Disconnect the two RS-485 cables from the unit as shown in the illustration below.
2. Remove the (12) 5/16" nut driver that secure the NGC-UIT2-HAZ to the panel door. **Save the mounting hardware - it will be needed later to secure the adapter plate to the panel.**
3. Disconnect the RS-485 communications wiring from the two RS-232 to RS-485 converters, from the Adam Relay Output module and the DIN rail terminals. Carefully tag the RS-485 wiring coming from the CRM(s) and Remote connections, as these will need to be re-connected once the new components and NGC-UIT3-EX have been installed.

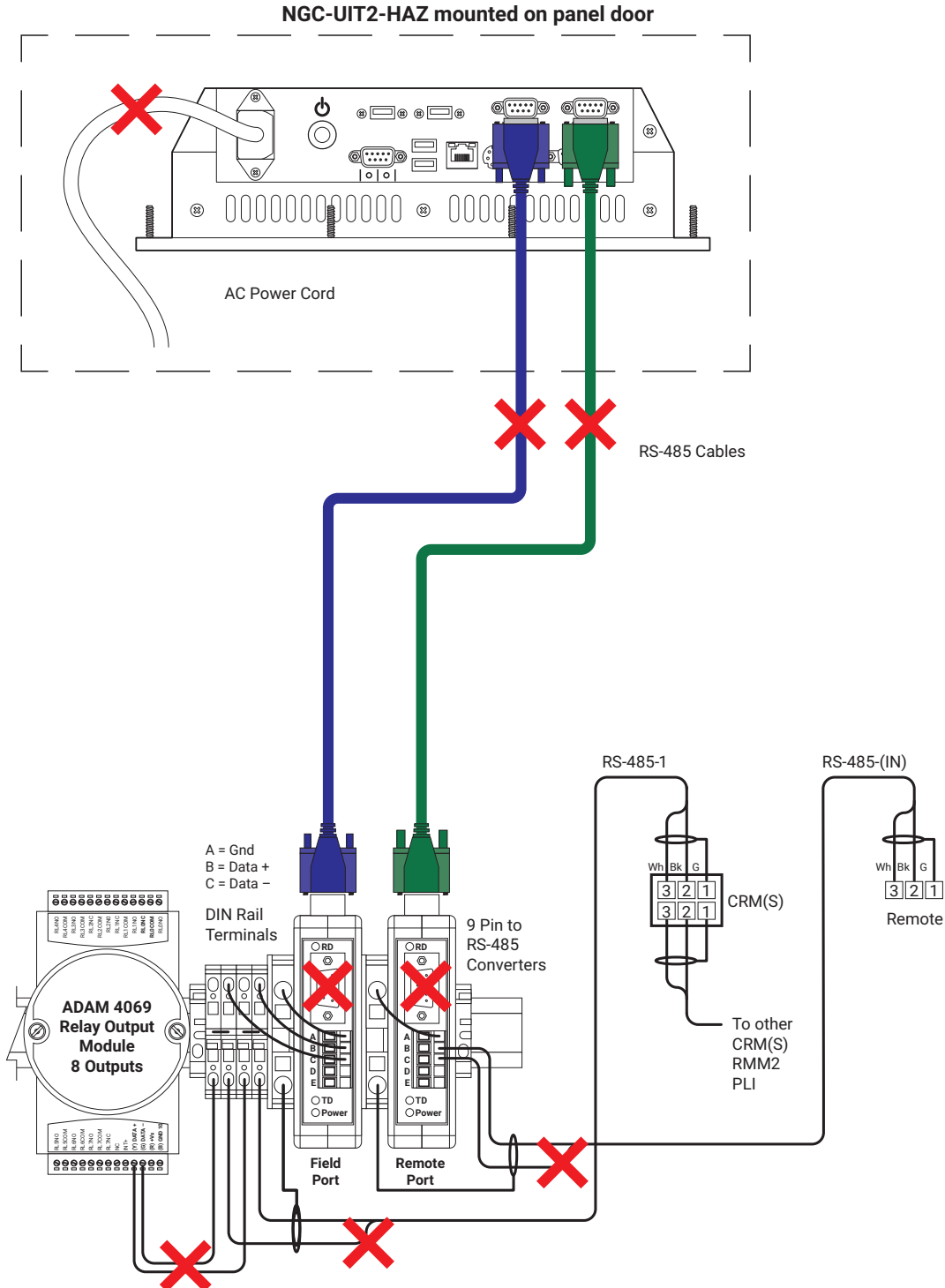

4. Next, disconnect the 12 Vdc wiring from the Adam module.

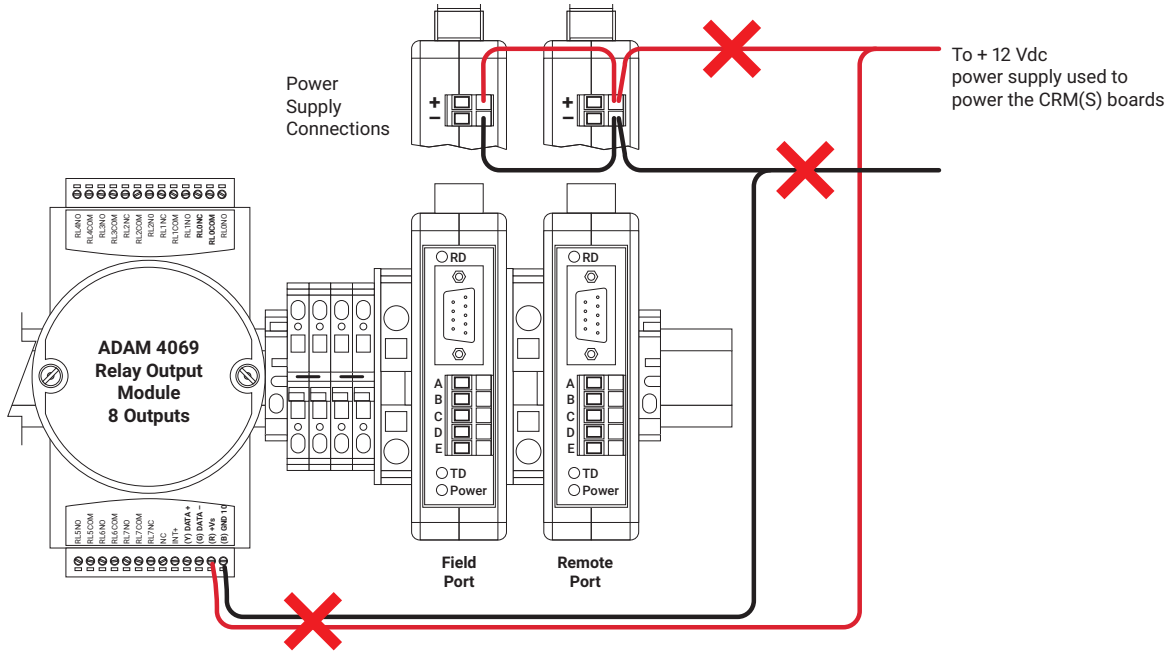

5. Disconnect any alarm relay wiring from the Adam module. Be sure to carefully label each set of wires (relay number, as well as NO, NC, and Common signals), as these will be reconnected to the new NGC-UIT3-EX once installed.

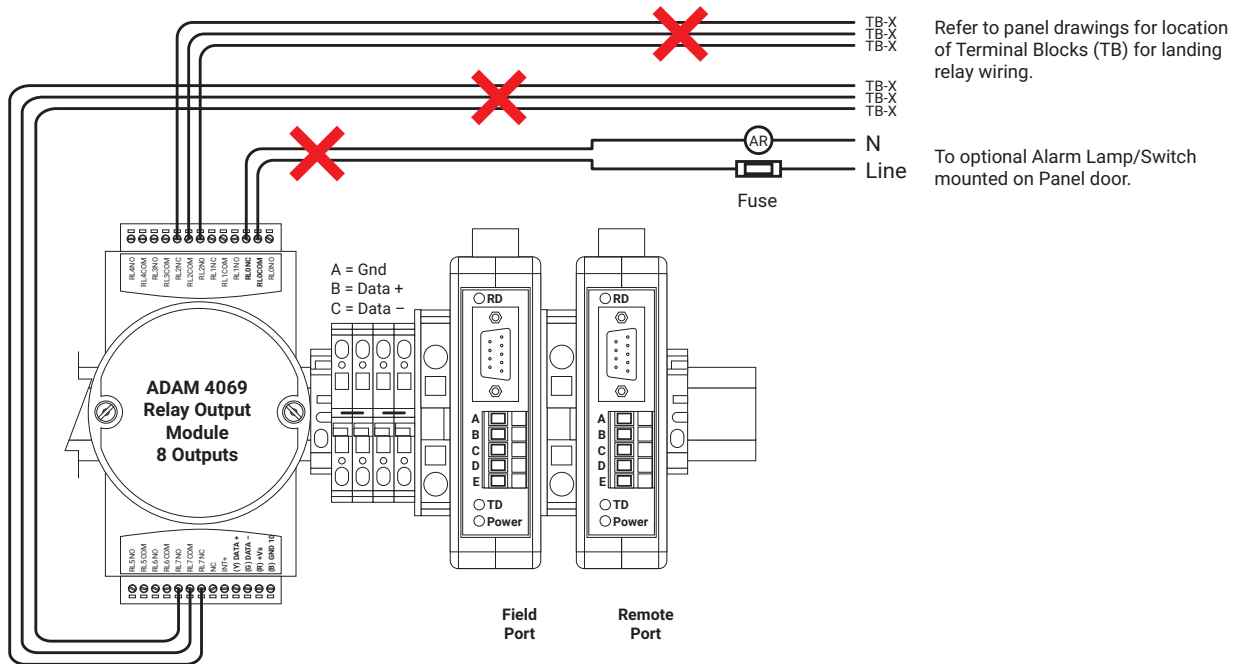

6. Remove components mounted to the DIN rail (Adam module, RS-232 to RS-485 converters).
7. Note that the four wiring terminals formerly used to connect the RS-485 signals should be retained since they will be re-used to distribute the 12 Vdc power to various components so they do not need to be removed. Further details are provided later in this document.

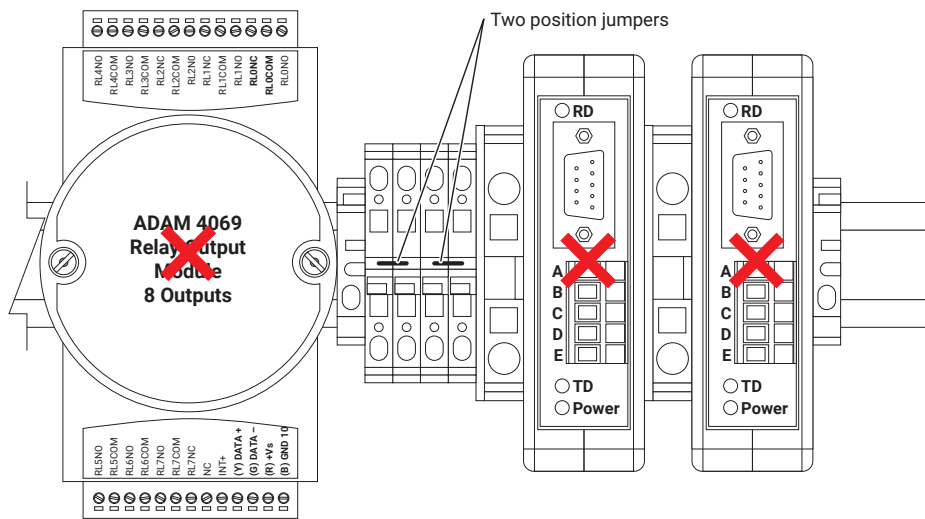

8. Install the new components onto the DIN rail as shown below. Note that the specific location or orientation of the components is not critical – choose the placement that makes wiring connections easiest to complete.

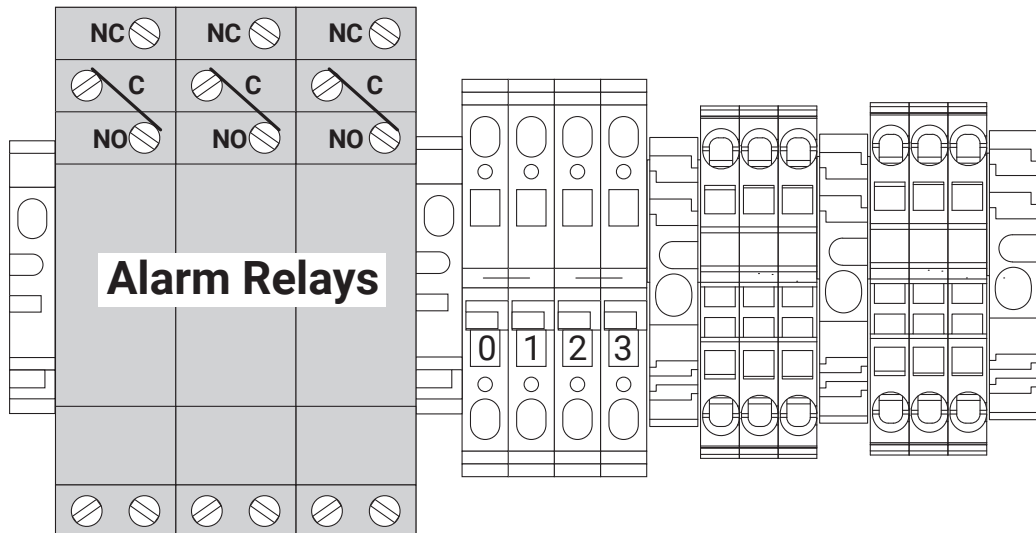

INSTALLING THE NGC-UIT3-EX AND ADAPTER PLATE INTO THE PANEL

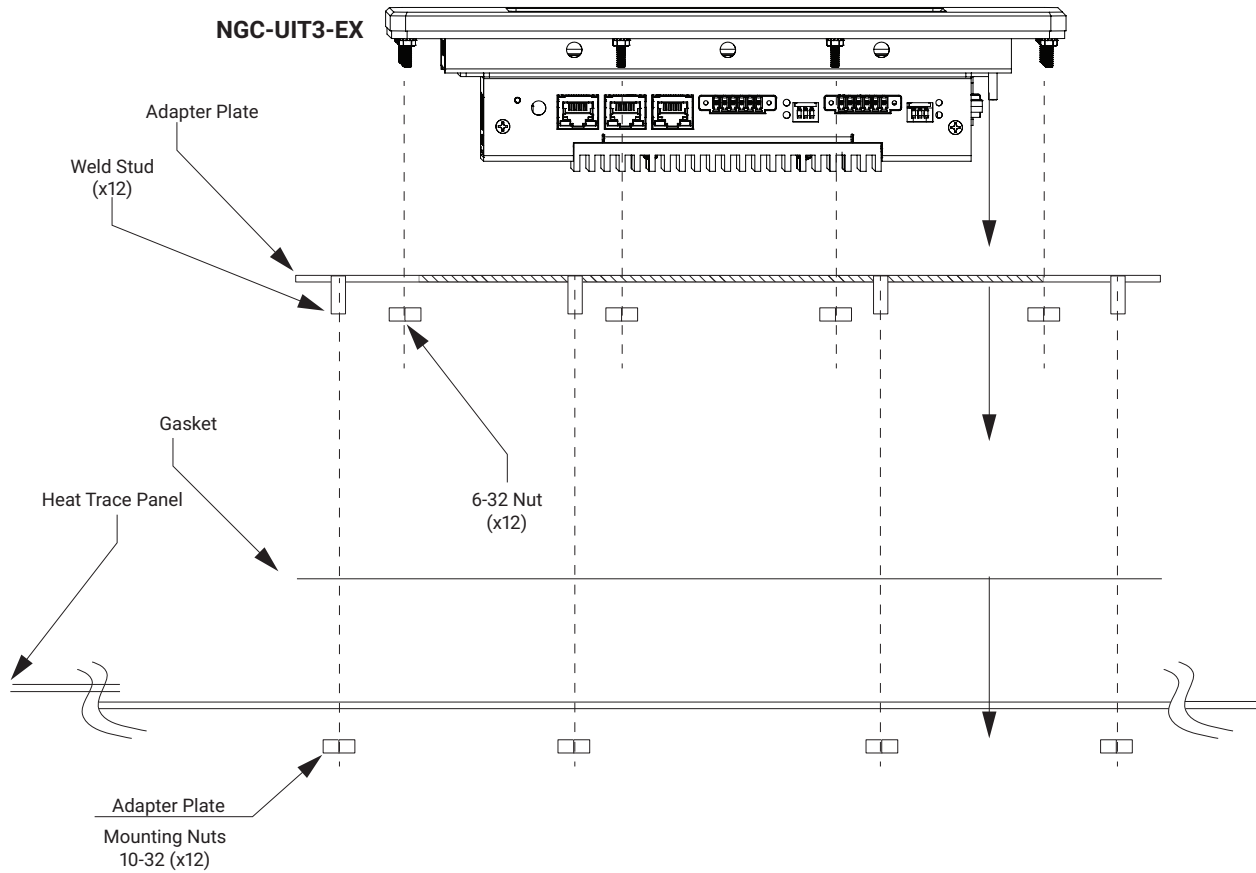

9. Install the NGC-UIT3-EX into the cutout in the adapter plate using the twelve 6-32 KepNuts supplied with the unit. Tighten the nuts to 0.56 N-m (5 in-lbs) of torque using the $\frac{5}{16}$ in nut driver in the sequence shown in the diagram below to ensure proper sealing.
10. Next, install the NGC-UIT3-EX and Adapter plate combination into the existing panel opening. Ensure that the gasket supplied with the kit is installed in between the Adapter plate and the panel opening.
11. Secure the Adapter plate using the twelve 10-32 nuts/lockwashers retained when the original NGC-UIT-HAZ was removed in Step 2 above.
12. Tighten the nuts to 0.9 N-m (8 in-lbs) of torque using the $\frac{3}{8}$ in nut driver in the sequence shown in the diagram below to ensure proper sealing.

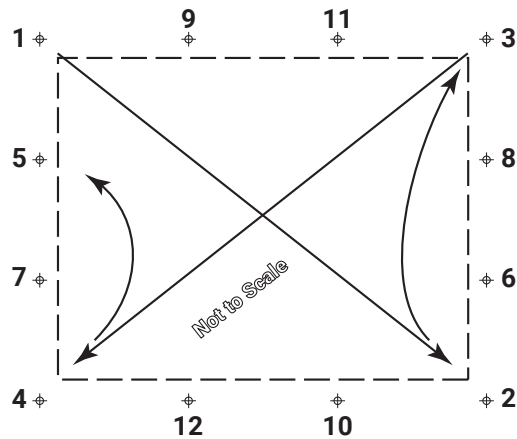

RECONNECT 12 VDC POWER TO COMPONENTS

13. Connect the 12 Vdc from the power supply used to power the CRM(s) boards to the DIN rail terminals as shown below. Be sure to connect the +12 V to the first terminal and the negative (common) to the third terminal. The jumpers installed in between terminals 1 & 2 as well as 3 & 4 should remain in place.
14. Connect the 12 Vdc from terminal 1 to each of the alarm relays as shown in the diagram below.
15. Connect 12 Vdc to the male power connector located on the left side of the NGC-UIT3-EX. The "+" lead should go from DIN terminal 2 to UIT3-EX terminal marked "9-30 Vdc" and the "-" lead should go from DIN terminal 4 to the UIT3-EX terminal marked "GND". Ensure that the cables are routed through the cable clamp as shown.

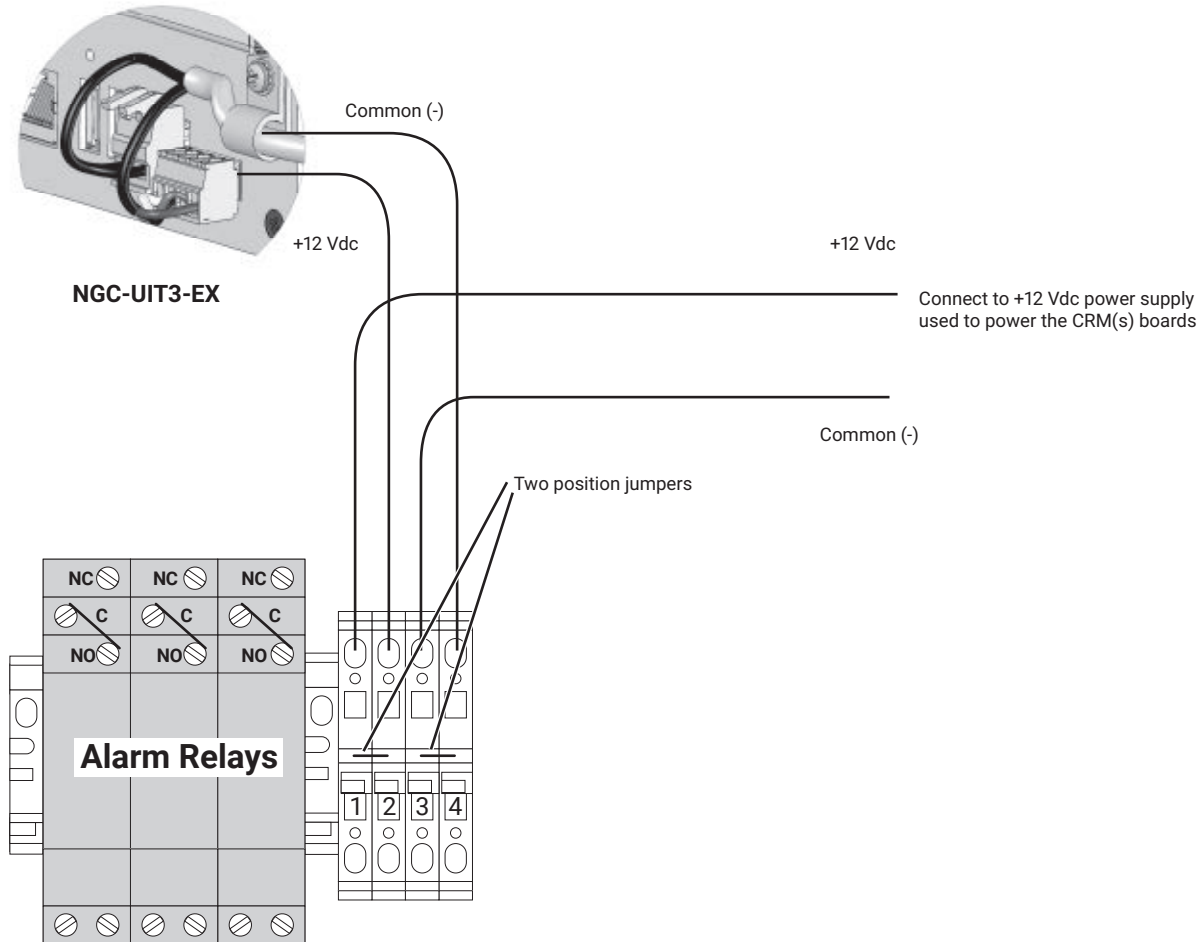

RECONNECT THE COMMUNICATIONS WIRING

19. Connect the RS-485 Field and Remote communications ports using shielded twisted pair wire included with the kit. Be sure to connect the Field Port terminals to the RS-485-1 serial port on the NGC-UIT3-EX, and the Remote port terminals to the RS-485-2 serial port on the NGC-UIT3-EX as shown below.
20. Reconnect the RS-485 field wiring (to/from the CRM(s) boards, RMMs, and other devices) that was disconnected in Step 3. Be careful to observe the polarity of the connections as well as ensuring that the shield connections are terminated as shown.
21. Repeat Step 20 for the Remote port (Host computer) connections.

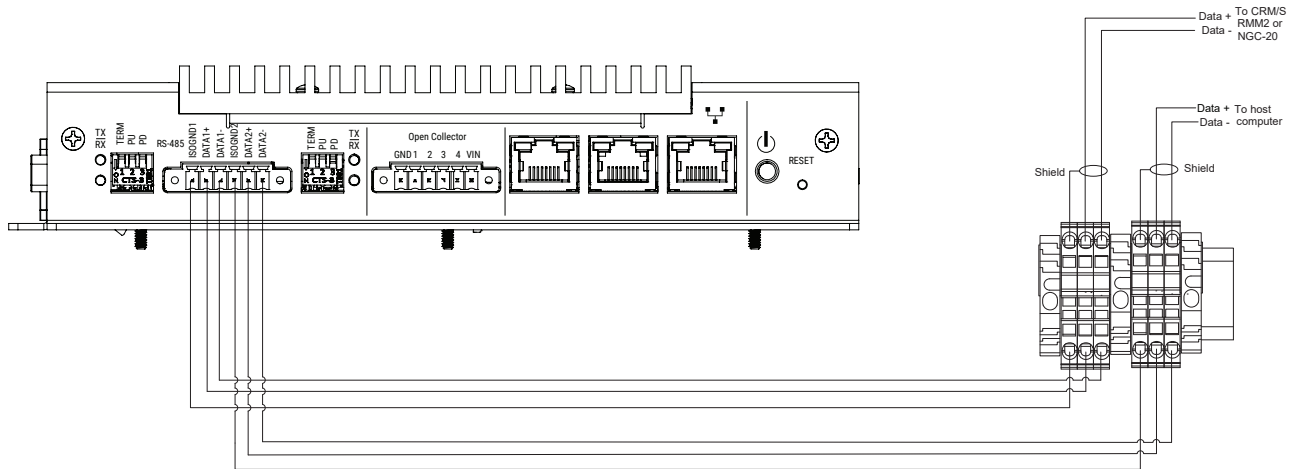

RS-485 CONFIGURATION SWITCHES

The configuration switches are found on the bottom of the NGC-UIT3-EX. Refer to the table below for settings.

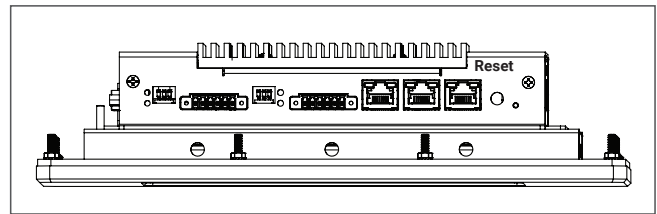

Switch	Position		Comments
	On	Off	
Pull-down	(As-shipped default) RS-485 network “-” signal is forced to a determinate state when idle.	RS-485 network “-” signal is not forced to a determinate state when idle.	One device (typically this NGC-UIT3-EX) on the RS-485 network should force the network “-” signal to a determinate state.
Pull-up	(As-shipped default) RS-485 network “+” signal is forced to a determinate state when idle.	RS-485 network “+” signal is not forced to a determinate state when idle.	One device (typically this NGC-UIT3-EX) on the RS-485 network should force the network “+” signal to a determinate state.
Termination	(As-shipped default) RS-485 network is terminated with 120-ohm resistor.	RS-485 network is not terminated.	Terminate the device (NGC-UIT3-EX or other) that is at each end of the RS-485 network, for a total of two terminated devices. No other devices on the network should be terminated.

RESET SWITCH

The Reset switch can be found on the bottom of the NGC-UIT3-EX. A pointed object is required to press the reset switch and restart the NGC-UIT software.

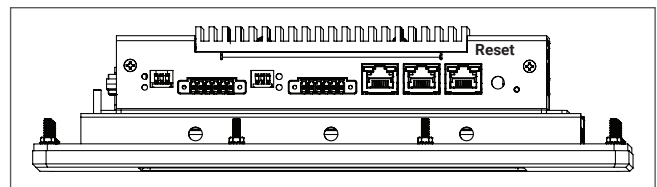



North America

Tel +1 800 545 6258
info@chemelex.com

Latin America

Tel +1 713 868 4800
info@chemelex.com

Europe, Middle East, Africa, India

Tel +32 16 213 511
Fax +32 16 213 604
info@chemelex.com

Asia Pacific

Tel +86 21 2412 1688
infoAPAC@chemelex.com

chemelex
excellence is everything

Raychem Tracer Pyrotenax Nuheat

©2025 Chemelex. All Chemelex marks and logos are owned or licensed by Chemelex Europe GmbH or its affiliates. All other trademarks are the property of their respective owners. Chemelex reserves the right to change specifications without notice.

RAYCHEM-IM-H60578-NGCUI2HAZtoUIT2EX-EN-2504

chemelex.com