

Raychem

MI Heating Cable System

Installation Instructions for Custom MI Heating
Cable Applications

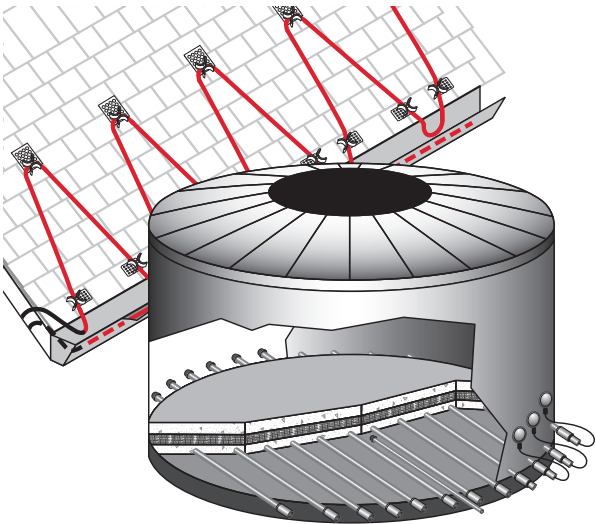

Important Safeguards and Warnings



WARNING: FIRE AND SHOCK HAZARD.

Raychem MI Heating Cable Systems must be installed correctly to ensure proper operation and to prevent shock and fire. Read these important warnings and carefully follow all the installation instructions.

- To avoid damage to the heating cables, do not energize cables until the installation has been completed.
- To minimize the danger of fire from sustained electrical arcing if the heating cable is damaged or improperly installed, and to comply with Chemelex requirements, agency certifications, and national electrical codes, ground-fault equipment protection must be used on each heating cable branch circuit. Arcing may not be stopped by conventional circuit breakers.
- Heating cables must be spaced at least 1/2 in (1.3 cm) from any combustible surface.
- Approvals and performance of the MI Heating Cable Systems are based on the use of approved components and accessories.
- Cable terminations must be kept dry before, during, and after installation.
- Energized exposed heating cables are hot and can cause burns. Take precautions to ensure that personnel in the area do not contact an energized heating cable.
- Damaged heating cable can cause electrical arcing or fire. Damaged heating cable or terminations must be repaired or replaced. Contact factory for assistance.
- If the heating cable sheath is stainless steel, the metal covering on the cable set shall be bonded to the circuit bonding conductor, but shall not be used as the circuit bonding means. Metallic structures or materials used for the support of, or on which the heating cables are installed, must be bonded to ground.
- To prevent fire or explosion in hazardous locations, verify that the maximum sheath temperature of the heating cable is lower than the auto-ignition temperature of the gases and vapors in the area. For further information, see the project design specifications.
- Reinforcing rod, mesh or other materials used for the support of, or on which the heating cables are installed, must be grounded in accordance with CSA Standard C22.1, Section 10 or the National Electrical Code as applicable.
- Megohmmeters operate at high voltage. This voltage is hazardous and possibly lethal. Read and follow all instructions included with the instrument you are using.

1.	General Information	5
1.1	Use of the Manual	5
1.2	MI Heating Cable Applications	6
1.3	Safety Guidelines	6
1.4	Electrical Codes	6
1.5	Approvals	6
1.6	Warranty	7
1.7	Heating Cable Identification	7
1.8	Heating Cable Identification	8

2.	General Installation Guidelines	9
2.1	Before You Start	9
2.2	Heating Cable Storage	9
2.3	Tools Required	9
2.4	Cable Testing Guidelines	9
2.5	General Installation Guidelines	10
2.6	Junction Boxes and Electrical Enclosures	11
2.7	Protecting the Heating Cable	12
2.8	Check Materials Received	12
2.9	Slab Temperature Sensor	12
2.10	Visual Inspection	13

3.	Heating Cable Installation	14
3.1	Roof and Gutter Deicing	14
3.2	Surface Snow and Ice Melting Using Heating Cables Installed Inside Pipe	22
3.3	Snow and Ice Melting on Exposed Surfaces	29
3.4	Frost Heave Protection for Cryogenic Storage Tanks	33
3.5	Tubular Heater Installation for Dam Gates	35
3.6	Soil Heating	39
3.7	Animal Pen Floor Heating	42

4.	Accessory Installation	46
4.1	Junction Boxes	46
4.2	Temperature Controller Installation	50

5.	Control, Monitoring and Power Distribution	52
5.1	Manual On/Off Control	52
5.2	Temperature Controller	52
5.3	Automatic Snow/Ice Melting Controller	52

6	Power Supply and Electrical Protection	53
6.1	Voltage Rating	53
6.2	Circuit Breaker Sizing	53
6.3	Ground-Fault Equipment Protection	53
6.4	Junction Box wiring	54
6.5	Typical Wiring Diagrams	55

7	Commissioning and Preventative Maintenance	58
7.1	System Tests	58
7.2	Preventative Maintenance	59

8	Test Procedures	60
8.1	Visual Inspection	60
8.2	Insulation Resistance Test – Test 1	60
8.3	Continuity (Resistance) Test – Test 2	61
8.4	Insulation Resistance and Continuity Test Procedure	61
8.5	Power Check	62
8.6	Fault Location Testing	65

9	Troubleshooting Guide	66
----------	------------------------------	-----------

10	Controllers and Accessories	70
-----------	------------------------------------	-----------

11	Installation and Inspection Records	90
-----------	--	-----------

1. GENERAL INFORMATION

1.1 Use of the Manual

This manual covers the installation of Raychem Mineral Insulated (MI) heating cables in nonhazardous areas for:

- Roof and gutter deicing
- Surface snow and ice melting using heating cables installed inside pipe
- Snow and ice melting on exposed surfaces
- Soil heating
- Animal pen floor heating
- Tubular heaters used to prevent the formation of ice around dam gates

The manual also covers the installation of MI heating cables in hazardous areas for:

- Roof and gutter deicing
- Surface snow and ice melting using heating cables installed inside pipe
- Frost heave protection for cryogenic storage tanks using heating cables installed inside pipe/conduit

The manual includes general heating cable installation procedures and specific installation details and provides information on testing and periodic maintenance.

This manual assumes that a proper heating system design has been completed according to Chemelex' recommendations. The applications described in this manual are approved by Chemelex for Raychem MI heating cables and only when used with approved accessories. The instructions in this manual and the installation instructions included with the control systems, power distribution systems, and accessories must be followed for the Chemelex warranty to apply.

For design assistance, technical support, or information regarding other applications not shown here, please contact your Chemelex representative or Chemelex directly.

Chemelex

15375 Memorial Dr., Ste. 11

Houston, TX 77079

USA

Tel: +1.800.545.6258

info@chemelex.com

chemelex.com



Important: For the Chemelex warranty and agency approvals to apply, the instructions that are included in this manual and with associated products must be followed.

1.2 MI Heating Cable Applications

Specific installation instructions relating to each application can be found on the pages following:

Section 3.1 - Roof and gutter deicing (ordinary and hazardous locations)

Section 3.2 - Surface snow and ice melting, heating cables installed inside pipe (ordinary and hazardous locations)

Section 3.3 - Snow melting on exposed surfaces (ordinary locations only)

Section 3.4 - Frost heave protection, heating cables installed inside pipe/conduit for cryogenic storage tanks (hazardous locations)

Section 3.5 - Tubular heaters for dam gate deicing (ordinary locations only)

Section 3.6 - Soil heating (ordinary locations only)

Section 3.7 - Animal pen floor heating (ordinary locations only)

1.3 Safety Guidelines

As with any electrical equipment, the safety and reliability of any heat-tracing system depends on the quality of the products selected and the manner in which they are installed and maintained. Incorrect design, handling, installation, or maintenance of any of the system components could damage the heating system and may result in inadequate heating system performance, electric shock, or fire. To minimize these risks and to ensure that the system performs reliably, read and carefully follow the information, warnings, and instructions in this guide.

Pay special attention to the following:

Notes are marked  **Note**

Important Instructions are marked  **Important**

Warnings are identified as  **Warning**

1.4 Electrical Codes

Articles 424 and 426 and Article 500 of the National Electrical Code and Section 62 and Section 18 of the Canadian Electrical Code, Part 1, govern the installation of heating systems in nonhazardous and hazardous locations. Installation of heating systems must comply with all national and local codes. In particular, ground-fault equipment protection is required for all electric heating installations to prevent arcing, fire, and shock if the cable is improperly installed or damaged.

1.5 Approvals

MI heating cables are approved for use in nonhazardous and hazardous locations. For a complete list of approvals, refer to product data sheets available on our website at chemelex.com or contact your Chemelex representative.

- H56990 – Copper and LSZH Jacketed Copper Sheathed MI Cable for Commercial and Industrial Applications data sheet
- H56870 – XMI-A (Alloy 825) High Temperature Constant Wattage Mineral Insulated Heating Cables data sheet

1.6 Warranty

Chemelex' standard limited warranty applies to MI Heating Cable Systems.



An extension of the limited warranty period to ten (10) years from the date of installation is available, except for the control and distribution systems, if a properly completed online warranty form is submitted within thirty (30) days from the date

of installation. You can access the complete warranty on our website at chemelex.com



Note: This extended warranty is not available for TH type tubular heaters used for dam gate deicing.

1.7 Heating Cable Configurations

The heating cables are available as factory-terminated units in the configurations shown in Figure 1. The "D" design heating cable with a reversed gland and pulling eye must be used for installations in pipe.

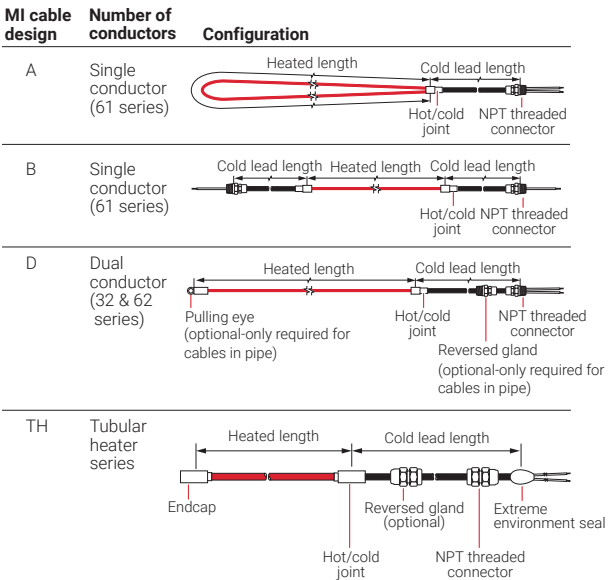

Figure 1: Typical MI heating cable configurations

1.8 Heating Cable Identification

Each MI heating cable is supplied with an identification tag on which the heating cable catalog number is permanently printed. In addition to its identification purposes, the catalog number provides information regarding the heating cable length, power output, and operating voltage. Also printed on the tag are the designer's circuit identification number, serial number and the maximum temperature the cable sheath may attain along with other design information.

If the cable has been designed for a hazardous location, the area classification is printed in the "Hazardous Locations" section of the tag.

CHEMELEX CANADA LTD.			
CATALOGUE NO. NO. DE CATALOGUE:		DESIGN / CABLE REF. / LENGTH / WATTS / VOLTS / C.L. LENGTH / C.L. CODE / JOINT / GLAND DESSIN / REF. DU CABLE / LONGUEUR / WATTS / VOLTS / C.L. LONG / CODE C.L. / JOINT / PRESSE-E-TOUPE D/32SA2275/50/120/130/7/LS23A/X/N12	
ORDER NO. NO DE COMMANDE:	727051	CUSTOMER ORDER NO. NO DE COMMANDE DU CLIENT:	7038622
SERIAL NO. NO DE SERIE:	19-166341201	CIRCUIT ID. ID. DU CIRCUIT:	12-PASC-2152-0-01
OUTPUT POWER: PUISSANCE DE SORTIE:	@ 130.0 V 120 W	@ MAINTAIN TEMP OF: TEMP E MAINTIEN:	
MAX SHEATH TEMP: TEMP DE GAINÉ MAXIMALE:	215°C	SHEATH REF TEMP: TEMP DE REF DE LA GAINÉ:	
DESIGN METHOD: METHODE DE DESIGN:		USAGE CODE: CODE D UTILISATION:	PS
CERTIFICATION REF: NO DE CERTIFICATION:	157944	T (CODE) / AIT: T (CODE DE) / TAI:	T2D
HAZARDOUS LOCATIONS: EMPLACEMENTS DANGEREUX: cCSAus CL I, II, III Div 1 Grp A,B,C,D,E,F,G Ex e IIC Class I Zone 1 Aex e IIC			
FOLLOW INSTALLATION AND OPERATION INSTRUCTIONS FOR SAFE USE IN HARARDOUS AREA! SVP VOUS REFERER AUX INSTRUCTIONS D'INSTALLATION.			
(SEE OTHER SIDE -- VOIR AUVERSO)		THIS TAG MUST NOT BE REMOVED - N'ENLEVEZ PAS CETTE ETIQUETTE	

Figure 2: Typical MI identification tag (front)

⚠ WARNING: Fire or explosion hazard. Ensure that the information provided in the Hazardous Locations and Max. Sheath Temp. [T (Code)/AIT] fields comply with the area in which the heating cable will be installed.

The heating cable catalog number may be broken out as follows:

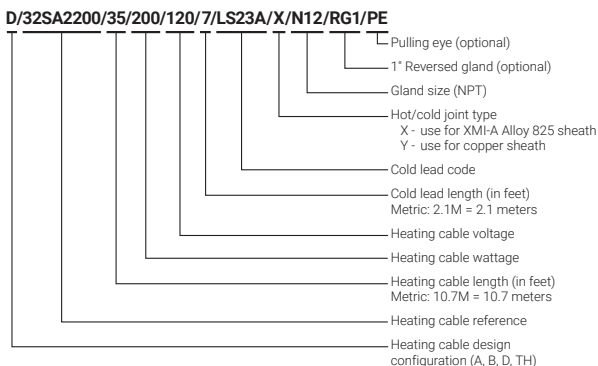

Figure 3: MI heating cable catalog number

2. GENERAL INSTALLATION GUIDELINES

The guidelines in Section 2 are provided to assist the installer throughout the installation process and should be reviewed before the installation begins.

2.1 Before You Start

These heating systems are engineered systems that have been designed for your application. To ensure a smooth, efficient installation and start-up, obtain all the relevant engineering information before commencing work. Contact the general contractor, owner, or owner's representative to obtain a statement of the project design basis, project specifications the heating cable layout drawings.

2.2 Heating Cable Storage

- Store the heating cables in a clean, dry location, in their shipping containers.
- Temperature range: -40°F to 140°F (-40°C to 60°C).
- Protect the heating cable from mechanical damage.

2.3 Tools Required

The following tools are recommended for installing MI heating cables.

- Pliers
- 500 Vdc or 1000 Vdc megohmmeter (1000 Vdc recommended)
- Multimeter
- Large adjustable wrench
- Torque wrench
- Pay-off reel (to uncoil long cables)

2.4 Cable Testing Guidelines

Insulation resistance (IR) testing is recommended at four stages during the installation process and as part of regularly scheduled maintenance. Further details on Testing can be found in Section 8.

- When received (prior to installation) – minimum 100 M Ω
- Continuously during placement of soil, concrete, etc. – minimum 20 M Ω
- After the cables have been installed – minimum 20 M Ω
- Prior to initial start-up (commissioning) – minimum 20 M Ω including branch circuit wiring
- As part of the regular system inspection
- After any maintenance or repair work

2.5 General Installation Guidelines

Avoid damage to the MI heating cable as follows:

- Do not energize cables before the installation is complete.
- Use a pay-off reel to uncoil heating cable during installation; do not pull cable out into a spiral (Figure 4).

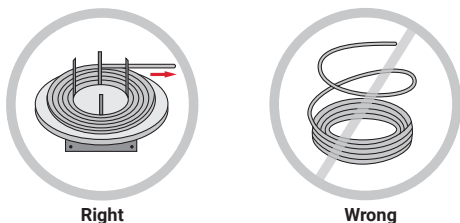

Figure 4: Unreeling/uncoiling cable

- Do not alter cable length.
- Avoid damaging heating cables by cutting or crushing (Figure 5).

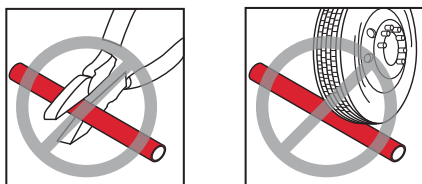

Figure 5: Avoid cutting and crushing the heating cable

- Minimum installation temperature:
 - Bare copper sheath and Alloy 825 sheath cables: -76°F (-60°C)
 - LSZH jacketed copper sheath cables: -4°F (-20°C) for UL, -22°F (-30°C) for CSA
- Do not install so that heating cables are crossed, overlapped, or grouped (Figure 6). Grouped heating cables can cause localized overheating with a risk of fire or cable failure.



Figure 6: Do not cross, overlap, or group heating cables

- Do not repeatedly bend and straighten the cable.
- Do not install heating cable in contact with combustible materials.

- Install heating cable at the recommended spacing to ensure correct watt density.
- For embedded applications, use a plank to tip wheelbarrow on.
- Handle the hot/cold joint carefully. Support the joint on both sides when moving and positioning the cold lead.
- Position hot/cold joints 6 in (15 cm) in from edge of heated areas and spaced at least 6 in (15 cm) apart from each other (do not bunch hot/cold joints – see Figure 7).

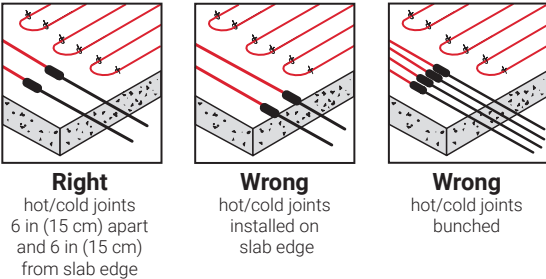

Figure 7: Positioning hot/cold joints

- During installation, protect tails from breaking where they emerge from brass pot by taping over tails and pot with electrical tape.
- Do not bend the heating cable or cold lead within 6 in (15 cm) of a splice, the hot/cold joint, or the end cap.
- Do not bend cable to an inside radius less than 6 times the outside diameter of the cable.
- Do not space runs of heating cable closer than 3 in (7.5 cm) together.
- Do not use sharp objects such as shovels, rakes, etc. when installing the cable (Figure 8).

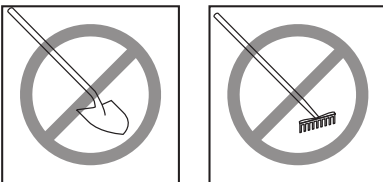

Figure 8: Avoid damage by not using shovels or rakes

2.6 Junction Boxes and Electrical Enclosures

- Junction boxes and enclosures used for electrical connections to the heating cables must be listed and approved for the environment in which they are installed, such as ordinary, wet or hazardous areas.

- Junction boxes should be mounted indoors or above grade when possible.
- Keep covers on junction boxes to prevent moisture from entering them.

2.7 Protecting the Heating Cable

On many projects, there is a delay between installation of the heating cables and final completion work, such as covering the cables with concrete or soil. If there is any delay at all, take the following precautions to protect the installation until the heating cables can be completely covered.

- **Do not energize the heating cables.**
- Mechanically protect the heating cables so that they cannot be damaged by being walked on, run over, painted, sandblasted, burned, welded, or cut.

2.8 Check Materials Received

Review the project specifications, drawings, and schedules and compare the list of materials to the catalog numbers of heating cables and components received to confirm that proper materials are on site. The heating cable catalog number, voltage, wattage, and length are printed on the metal tag attached to the cold lead.

- Ensure that the heating cable voltage rating is suitable for the power supply voltage available.
- Inspect the heating cable and components for in-transit damage.
- Perform continuity and insulation resistance testing (minimum 100 M Ω) on each cable as detailed in Section 8 and record the results in the Heating Cable Installation Record in Section 11.

2.9 Slab Temperature Sensor

All applications should be controlled with a thermostat or electronic controller, including embedded snow melting applications where the heating cables may be controlled with an automatic snow/ice melting controller. For snow/ice melting applications, the thermostat or electronic controller can be used to limit the maximum temperature of the slab, improving energy efficiency. Some applications, such as soil heating, animal pen floor heating and frost heave protection, will require only a thermostat or temperature controller to regulate the temperature.

The temperature sensor should be installed in metal or plastic conduit/pipe placed between two runs of heating cable. Do not allow the conduit/pipe to touch the heating cable. Cap the buried end of the conduit/pipe so that it is watertight. Ensure that the sensor can fit past all bends in the conduit/pipe prior to installation of the conduit/pipe. The conduit/pipe should be long enough to extend out to approximately the middle of the area being heated.

2.10 Visual Inspection

A visual inspection of the heating system should be made before placement of the concrete or soil, connection into pipe, etc. to ensure proper installation of the system.

- Verify that there is no mechanical damage to the heating cables (cuts, breaks, burns, scrapes, etc.).
- Verify proper heating cable spacing, depth, etc. for the application where applicable.
- Verify proper heating cable fastening method (no wire).
- Ensure heating cable does not cross expansion joints. If crossing expansion joints cannot be avoided, contact Chemelex technical support.
- For directly embedded heating cables, verify that the cold leads are protected with nonmetallic conduit where they emerge from the heated area.
- For directly embedded heating cables, verify that the hot/cold joints are 6 in (15 cm) in from the edge of the heated area, are not bunched together, and spaced at least 6 in (15 cm) apart from each other (see Figure 7).
- Verify that the junction boxes are properly installed per manufacturer's instructions and the details in Section 4.

 **WARNING:** Damaged heating cables can cause sustained electrical arcing or fire. Do not energize cables that have been damaged. Repair or replace damaged heating cable or terminations before energizing the circuit.

For installation assistance or technical support, please contact your Chemelex representative or Chemelex directly at (800) 545-6258.

3. HEATING CABLE INSTALLATION

This section provides instructions to install the heating cables for the applications shown below. Read and follow these instructions to ensure that the snow melting system performs reliably and as intended.

- Section 3.1 covers heating cable installation for roof and gutter deicing
- Section 3.2 covers heating cable installation inside pipe for surface snow and ice melting - including garage doors and aircraft hangar doors
- Section 3.3 covers heating cable installation for snow melting on exposed surfaces
- Section 3.4 covers heating cable installation inside pipe for frost heave prevention of cryogenic storage tanks - including LNG, LPG (propane, butane, ethylene), and ammonia storage tanks
- Section 3.5 covers tubular heater installation for dam gate deicing
- Section 3.6 covers heating cable installation for soil heating
- Section 3.7 covers heating cable installation for animal pen floor heating

3.1 Roof and Gutter Deicing

These instructions show how to install MI heating cables along roofs and gutters to help prevent the formation of ice dams and icicles in both ordinary and hazardous locations. To maintain a continuous path for melt water runoff, heating cables serpentine along the roof with one or two runs in the gutter and downspout can provide a continuous path for melt water to run off. Review and understand the technical requirements in Section 2 prior to installing the heating cables.

Steps 1 and 2 and Steps 6, 7, 8 and 9 apply to all installations. Steps 3, 4 and 5 cover specific installation details for Gutters and Downspouts, Sloped roof - non-standing seam, Valleys and Sloped roof - standing seam.

1. Install UL Listed or CSA Certified junction boxes suitable for the area classification (see Section 4 for details). For single conductor cables, the cable layout should begin and end at or close to the junction box to allow the cold leads to be fed back to the junction box.
2. Before installing the heating cable, check the insulation resistance and continuity to verify that the cable was not damaged during shipment. Details on testing can be found in Section 8. Record the results of the tests in the Heating Cable Installation Record in Section 11.



Important: If installing the heating cable in a hazardous area, verify that the appropriate hazardous area requirements are marked in the "Hazardous Location" section of the metal tag attached to the cold lead and follow all applicable electrical codes and standards for installation in hazardous areas.

Continue with Steps 3, 4 and 5 in each of the four sections following that cover specific installation details for Gutters and downspouts, Sloped roof – non-standing seam, Valleys and Sloped roof – standing seam.

Gutters and downspouts

Ice build-up in gutters and downspouts can prevent melt water from draining away, causing the gutters to overflow and form dangerous icicles. Installing heating cable in the gutters and downspouts can provide a continuous path for melt water to run off.

3. Install one or two passes of heating cable in the gutter as per the design requirements (Figure 9 shows a double run of cable); if also installing the heating cable along the edge of a non-standing seam roof as in Figure 10, it will only be possible to install one run of cable in the gutter. It is not necessary to attach the heating cable to the gutters. If attachment is required, use 2 in (50 mm) wide adhesive metal foil tape to secure the cable to the bottom of the gutter.

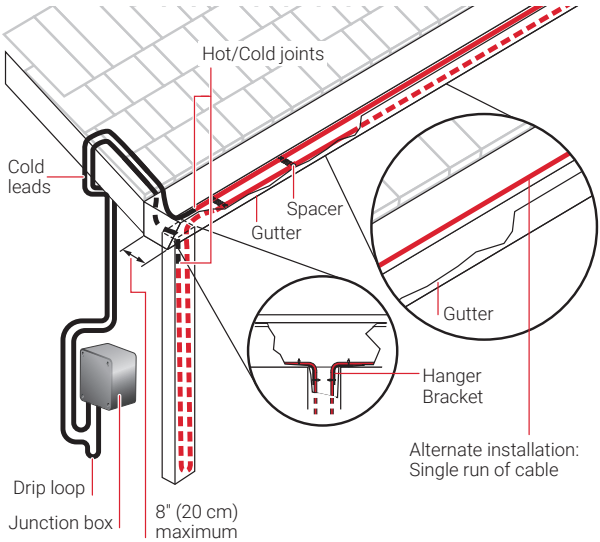

Figure 9: Gutters and downspouts

4. Install the hot/cold joints so that they are inside the gutter or downspout and, if necessary, protect the cold leads with nonmetallic conduit if they emerge from the gutter in an area where they may be damaged.
5. Loop the heating cable into each downspout as required taking care not to damage the heating cable. The cable should extend all of the way down to the bottom of the downspouts.



Important: If the cable is damaged during installation, the insulation resistance will immediately decrease – check cable with the megohmmeter. If the cable was damaged, protect the damaged section from moisture with several layers of PVC tape. Installation can then continue and repairs made after the installation is complete.

If the installation is complete, continue with Step 6, otherwise continue with the installation details following, if applicable.

Sloped roof – non-standing seam

For sloped roofs, ice dams may form at the roof edge. To maintain a continuous path for melt water runoff, route the heating cable in a serpentine pattern as shown in Figure 10. Additional heating cable may be needed for downspouts and valleys.

- Run heating cable up the roof, at the required angle, until it is at least 12 in (30 cm) past the exterior building wall and into the heated area below the roof (Figure 10). Handle heating cable carefully to avoid damaging the cable. Secure cable in place using roof clips available from the manufacturer. Table 1 shows the heating cable required per foot of roof edge for several common “Tracing heights” and includes one run along the gutter and a 3 in (7.5 cm) drip loop into the gutter every 18 in (46 cm).

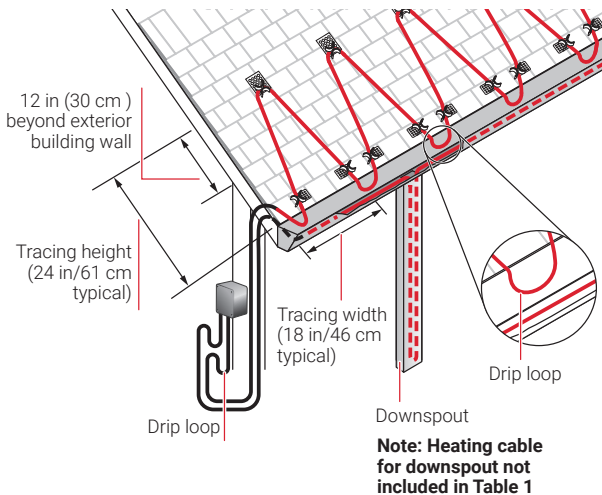

Figure 10: Layout for sloped roof - non-standing seam

- Continue installing the cable in a serpentine (zigzag) pattern, maintaining 18 in (46 cm) spacing between zigzags. Ensure that the bottom drip loop of the heating cable extends (overhangs) into the gutter as shown in Figure 10. This provides a continuous path for melt water to flow from the roof into the gutters.

- Install a single run of cable back along the gutter with a loop into each downspout as shown in Figure 10 (gutters wider than 6 in (15 cm) may require 2 or more runs of heating cable). The loop should extend all of the way down to the bottom of the downspouts. It is not necessary to attach the heating cable to the gutters. If attachment is required, use 2 in (5 cm) wide adhesive metal foil tape to secure the cable to the bottom of the gutter.



Important: If the cable is damaged during installation, the insulation resistance will immediately decrease – check cable with the megohmmeter. If damaged, protect the damaged section from moisture with several layers of PVC tape. Installation can then continue and repairs made after the installation is complete.

Table 1: Heating cable length for sloped roof (non-standing seam)

Eave overhang distance	Tracing width	Tracing height	Feet of heating cable per foot of roof edge*	Meters of heating cable per meter of roof edge*
None	18 in (46 cm)	12 in (30 cm)	3.0 ft	3.0 m
12 in (30 cm)	18 in (46 cm)	24 in (61 cm)	4.2 ft	4.2 m
24 in (61 cm)	18 in (46 cm)	36 in (91 cm)	5.5 ft	5.5 m
36 in (91 cm)	18 in (46 cm)	48 in (122 cm)	6.8 ft	6.8 m

*Includes one run in gutter and 3 in (7.5 cm) drip loop every 18 in (46 cm)

Note: Values in Table 1 do not include heating cable for downspouts

If the installation is complete, continue with Step 6, otherwise continue with the installation details following, if applicable.

Valleys

Ice dams may form at the valley on a roof where two different slopes meet. To maintain a continuous path for melt water, run the heating cable up and down the valley as shown in Figures 11 and 12. Additional heating cable may be needed for the roof surface, gutters, and downspouts.

- Trace two-thirds of the way up each valley with a double run of heating cable (loop up and back once) as shown in Figure 11 taking care not to damage the heating cable. Secure cable in place using roof clips available from the manufacturer.

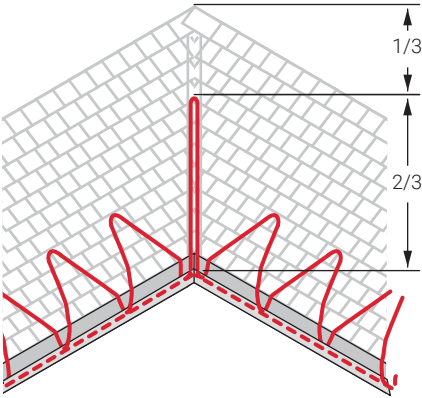

Figure 11: Layout for valley

4. The heating cable must extend into the gutter. If there are no gutters, the heating cable should extend over the edge 2 to 3 in (5 to 7.5 cm) to form a drip loop.
5. Continue laying out heating cable along roof, tracing roof edge, gutters and downspouts as required.

Important: If the cable is damaged during installation, the insulation resistance will immediately decrease – check cable with megohmmeter. If damaged, protect the damaged section from moisture with several layers of PVC tape. Installation can then continue and repairs made after the installation is complete.

Note: An alternate installation method is to lay out the heating cable in serpentine pattern along each side of the valley as shown in Figure 12, tracing two-thirds of the way up the valley. Serpentine heating cable using a 12 in (30 cm) zigzag height and 12 in (30 cm) zigzag width. Secure cable in place using roof clips available from the manufacturer - this method requires additional heating cable.

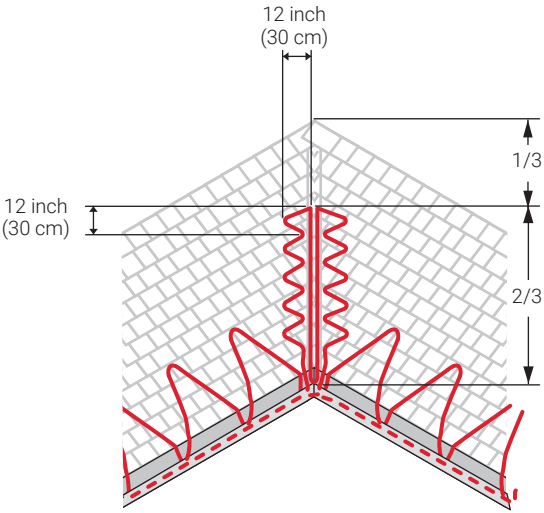

Figure 12: Alternate layout for valley

If the installation is complete, continue with Step 6, otherwise continue with the installation details following, if applicable.

Sloped roof – standing seam

For sloped standing seam metal roofs, ice dams may form at the roof edge. To maintain a continuous path for melt water runoff, route the heating cable along the seams as shown in Figure 13 below. Additional heating cable may be needed for downspouts and valleys.

3. Run heating cable up the seam until it is at least 12 in (30 cm) past the exterior building wall and into the heated area below the roof taking care not to damage the heating cable. Secure cable in place using one-hole clips or other similar attachment clip. Table 2 shows the heating cable required per foot of roof edge for several common “Tracing heights” and includes two runs along the gutter (see details in Figure 13).

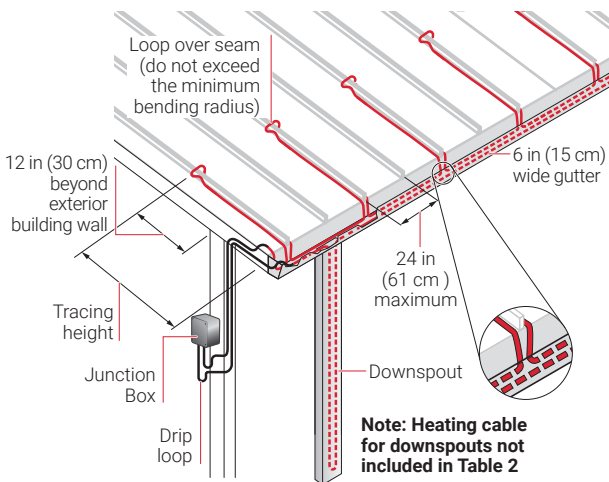

Figure 13: Layout for standing seam roof

- Run the heating cable up one side of the seam, loop it over to the other side, taking care not to exceed the minimum bending radius, and return it to the bottom of the gutter. Continue along the bottom of the gutter to the third seam and repeat the process as shown in Figure 13. If the seams are more than 24" apart, trace every seam.
- Loop heating cable into each downspout as shown. The cable should extend all of the way down to the bottom of the downspouts. Install a single run of cable back along the gutter to the junction box as shown in Figure 13. It is not necessary to attach the heating cable to the gutters. If attachment is required, use 2 in (5 cm) wide metal foil adhesive tape to secure the cable to the bottom of the gutter.

Important: If the cable is damaged during installation, the insulation resistance will immediately decrease – check cable with the megohmmeter. If damaged, protect the damaged section from moisture with several layers of PVC tape. Installation can then continue and repairs made after the installation is complete.

Table 2: Heating Cable Length for Standing Seam Roofs

Eave overhang distance	Standing seam spacing	Tracing height	Feet of heating cable per foot of roof edge**	Meters of heating cable per meter of roof edge**
12 in (30 cm)	18 in (46 cm)	24 in (61 cm)	3.8 ft	3.8 m
24 in (61 cm)	18 in (46 cm)	36 in (91 cm)	4.5 ft	4.5 m
36 in (91 cm)	18 in (46 cm)	48 in (122 cm)	5.2 ft	5.2 m
12 in (30 cm)	24 in (61 cm)	24 in (61 cm)	3.4 ft	3.4 m
24 in (61 cm)	24 in (61 cm)	36 in (91 cm)	3.9 ft	3.9 m
36 in (91 cm)	24 in (61 cm)	48 in (122 cm)	4.4 ft	4.4 m

** includes two runs of cable in gutter as shown in Figure 13

Note: Values in Table 2 do not include heating cable for downspouts

Continue with Step 6 following.

6. Visually inspect the heating cable, cold leads, and junction box (see Section 2.10) and record the results in the Heating Cable Installation Record in Section 11.
7. Before connecting the heating cable to the junction box, check the insulation resistance and continuity to verify that the cable was not damaged during installation. Details on testing can be found in Section 8. Minimum acceptable IR is 20 MΩ at 1000 Vdc. Record the results of the tests in the Heating Cable Installation Record in Section 11. Damaged cable must be repaired before energizing the heating cable.
8. Connect the cold leads to the junction box (refer to Section 4 for details).
9. Use an ambient sensing temperature controller or automatic gutter ice sensor as per project design specifications to control the heating cables. Set temperature controller to 40°F (5°C).

3.2 Surface Snow and Ice Melting Using Heating Cables Installed Inside Pipe

These instructions cover the installation of MI heating cables inside pipe for melting ice in concrete areas at the foot of garage doors to prevent the door from freezing to the concrete floor. It also covers the installation of MI heating cables inside pipe to prevent ice formation on aircraft hangar door rails. These applications may include both ordinary and hazardous areas. Review and understand the technical requirements in Section 2 prior to installing the heating cables.



Important: Reinforcement is necessary to ensure that the concrete is structurally sound. Concrete that cracks, crumbles, or settles can damage the heating cable. The reinforcement must be adequately supported so that it is not disturbed by the installation. It is important that the heating cable depth in the concrete be maintained for proper operation of the system.

Garage Doors

A single heating cable installed inside a pipe embedded in concrete below the garage door weather strip can be used to prevent the garage door from freezing to the concrete floor. Installing the heating cable in pipe increases the life expectancy of the cable and also simplifies maintenance and replacement of the heating cable. These applications may include both ordinary and hazardous areas.

1. Before installing the heating cable, check the insulation resistance and continuity to verify that the cable was not damaged during shipment. Details on testing can be found in Section 8. Record the results of the tests in the Heating Cable Installation Record in Section 11.



Important: If installing the heating cable in a hazardous area, verify that the appropriate hazardous area requirements are marked in the "Hazardous Location" section of the metal tag attached to the cold lead and follow all applicable electrical codes and standards for installation in hazardous areas.

2. Prepare 1 in (2.5 cm) steel pipe of the proper length as shown in Figure 14 (schedule 80 ASTM A-106 GR B standard weight seamless steel pipe recommended). One end must be capped and sealed so that it is air/liquid tight. The other end, where the heating cable will be inserted, must be prepared with a female 1 in NPT fitting to accept the male 1 in NPT fitting (Reversed Gland) on the heating cable cold lead (see Figure 1 in Section 1). If the heating cable will be installed in a hazardous location, ensure that the pipe and fittings all have the proper agency approvals.



Important: The bend in the pipe should not have a radius less than 12 in (30 cm). A smaller radius may result in difficulty installing the heating cable.



Note: The pipe must be accessible at both ends to allow a long heating cable to be pulled into it.

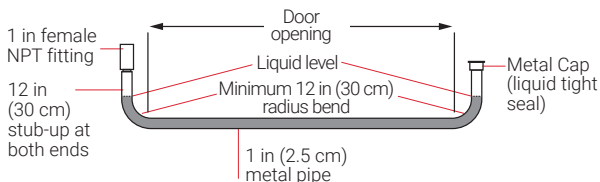

Notes:

- 1) All pipe and fittings must be suitable for the area classification. Use only approved pipe and fittings.
- 2) In hazardous areas, pipe must be filled with a heat transfer fluid.

Figure 14: Typical pipe profile for garage doors

3. Install the 1 in (2.5 cm) pipe for the heating cable so that it is located under the door opening (where the door weather seal will contact the concrete surface) and so that the top of the pipe is about 2 in (5 cm) below the finished level of concrete (see Figure 15).
4. Install the junction box and temperature controller close to the point where the heating cable will be inserted into the pipe. The junction box must be close enough to allow the heating cable cold lead to reach it.
5. Install the conduit for the slab temperature sensor about 3 in (7.5 cm) away from the heating cable pipe and located in the outdoor section of the slab (see Figure 15). Cap the buried end of the conduit so that it is watertight. Before covering with concrete, check that the temperature sensor will fit past the bend in the conduit. If using an automatic snow/ice sensing controller, follow the manufacturer's recommendations to install the slab snow/ice sensor.



Note: Do not install the temperature sensor at this time.

6. Visually inspect the heating cable pipe and the temperature sensor conduit for damage and to make sure that the ends are completely sealed. If using an automatic snow/ice sensing controller, make sure that the slab snow/ice sensor is mounted with the top of the sensor at the finished concrete level.
7. Pour the concrete topping to the final finished level – 2 in (5 cm) minimum to 3 in (7.5 cm) maximum above the top of the heating cable pipe as shown in Figure 15, and ensure that it is thoroughly consolidated with a high frequency vibrator. The concrete cover over the heating cables must be reinforced and structurally sound to prevent damage from heavy vehicles.
8. Allow the concrete to cure following the specifications in the contract documents.
9. Once the concrete has cured sufficiently, install the cable in the pipe. Short heating cables can usually be pushed into the

pipe, but longer cables may have to be pulled into the pipe (use a fish tape to feed a rope into the pipe and tie the rope to the pulling eye on the end of the heating cable). Pull on the rope from the far end of the pipe while someone else feeds/pushes the heating cable at the other end.

10. For hazardous area installations, fill the pipe with an EPA friendly glycol or a heat transfer oil ensuring that the heating cable will be completely immersed while leaving space for liquid expansion. Follow the respective manufacturer's installation recommendations to install/mix the glycol or heat transfer oil.



Note: If the garage door is in a non-hazardous location, it is not necessary to fill the pipe with glycol or a heat transfer oil.

11. Check the insulation resistance of the heating cable after it has been installed in the pipe – minimum acceptable IR is 20 MΩ at 1000 Vdc.
12. Tighten the reversed gland on the heating cable cold lead into the female NPT fitting on the pipe. Refer to the torque tag on the cold lead for proper torque. In hazardous areas, it is especially important that the gland be tightened to the specified torque.
13. Ensure drainage will be adequate for run-off of melted snow and ice.
14. Insert the temperature sensor into the conduit. Refer to Section 4.2 for details.
15. Connect the cold lead to the junction box per the recommendations in Section 4 and connect the temperature controller. Excess cold lead can be coiled into a 12 in (30 cm) diameter loop.
16. If using only a slab sensing temperature controller, set the controller to 40°F (5°C). If the heating cables will be controlled with an automatic snow/ice melting controller, follow the installation instructions supplied with the automatic snow/ice melting controller to install and connect the controller to the heating cables.

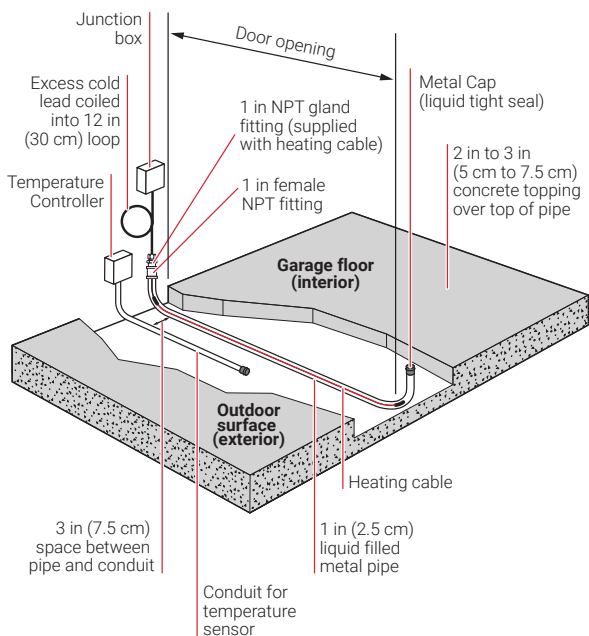

Figure 15: Typical garage door installation

Aircraft Hangar Doors

Heating cables are installed inside pipe embedded in the concrete near the hangar rails to prevent ice formation on the rails. Installing the heating cables in pipe increases the life expectancy of the cables and also simplifies maintenance and replacement of the cables. Hangar door rail deicing applications are generally classified as hazardous. Refer to Section 20-500 of the CEC and Article 513 of the NEC for additional information.

1. Before installing the heating cables, check the insulation resistance and continuity to verify that the cables were not damaged during shipment. Details on testing can be found in Section 8. Record the results of the tests in the Heating Cable Installation Record in Section 11.

Important: Verify that the appropriate hazardous area requirements for the hangar installation are marked in the “Hazardous Location” section of the metal tag attached to the cold lead and follow all applicable electrical codes and standards for installation in hazardous areas. Junction boxes, pipe, pipe fittings and bonding jumpers must be approved for the area classification.

2. Prepare 1 in (2.5 cm) steel pipe of the proper length as shown in Figure 16 or Figure 17 (schedule 80 ASTM A-106 GR B standard weight seamless steel pipe recommended). One end must be capped and sealed so that it is liquid tight. The other end, where the heating cable will be inserted, must be prepared with a female 1 in NPT fitting to accept the male 1 in NPT fitting (Reversed Gland) on the heating cable cold lead (see Figure 1 in Section 1). Ensure that the pipe and fittings all have the proper agency approvals for hazardous areas.

Important: The bend in the pipe should not have a radius less than 12 in (30 cm). A smaller radius may result in difficulty installing the heating cable.

Note: The pipes must be accessible at both ends to allow long heating cables to be pulled into them.

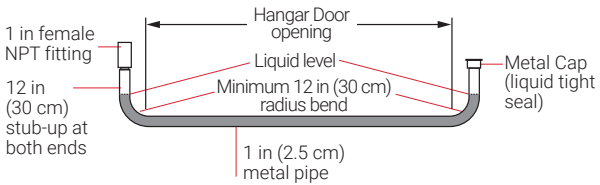

Note: All pipe and fittings must be suitable for the area classification. Use only approved pipe and fittings.

Figure 16: Typical pipe profile for hangar doors with pipe ends curved upwards

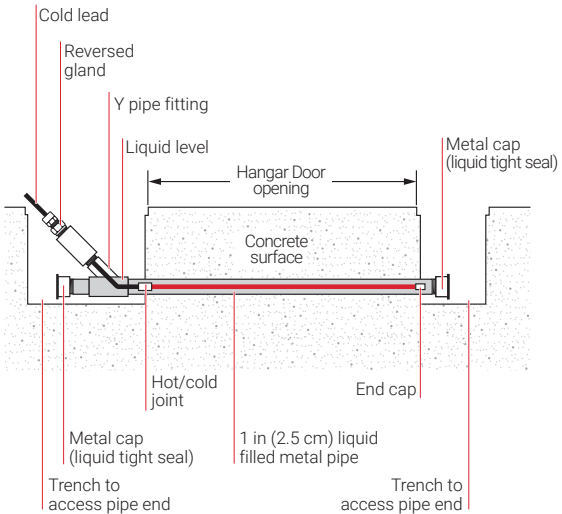

Note: All pipe and fittings must be suitable for the area classification. Use only approved pipe and fittings.

Figure 17: Typical pipe profile for hangar doors with trenches at either end

3. Install the 1 in (2.5 cm) pipes for the heating cables so that they are located on either side of the hangar door rails as shown in Figures 18 and 19, and at a depth that will allow for a 3 in (7.5 cm) minimum concrete topping over the top of the steel pipes.

Important: The concrete base must be of a high quality and to the thickness and strength required for the application. The concrete must be structurally sound to carry the weight of aircraft and heavy vehicles it must support.

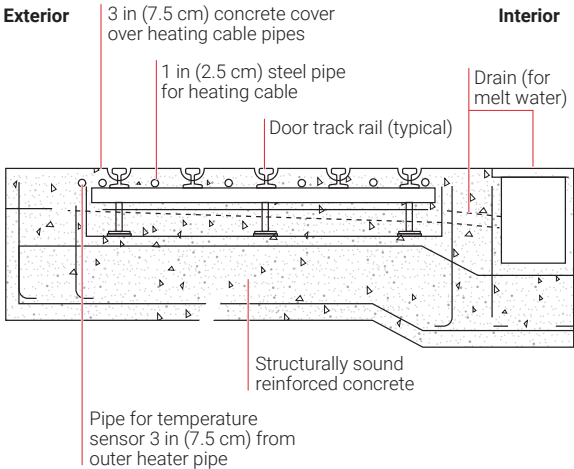

Figure 18: Typical cross-section of hangar door rails

4. Install the junction boxes and temperature controller close to the point where the heating cables will be inserted into the pipes. The junction boxes must be close enough to allow the heating cable cold leads to reach them.
5. Install the pipe for the slab temperature sensor about 3 in (7.5 cm) away from the outer heating cable pipe and located in the outdoor section of the slab (see Figures 18 and 19). Cap the buried end of the pipe so that it is watertight. Before covering with concrete, check that the temperature sensor will fit past the bend in the pipe. If using an automatic snow/ice sensing controller, follow the manufacturer's recommendations to install the slab snow/ice sensor.

Note: Do not install the temperature sensor at this time.

6. Visually inspect the heating cable and temperature sensor pipes for damage and to make sure that the ends are completely sealed. If using an automatic snow/ice sensing controller, make sure that the slab snow/ice sensor is mounted with the top of the sensor at the finished concrete level.

7. Pour a high quality concrete topping to the final finished level – 3 in (7.5 cm) minimum above the top of the heating cable pipes as shown in Figures 18 and 19, and ensure that it is thoroughly consolidated with a high frequency vibrator. The concrete cover over the heating cables must be reinforced and structurally sound to prevent damage from aircraft and other heavy vehicles.
8. Allow the concrete to cure following the specifications in the contract documents.
9. Once the concrete has cured sufficiently, install the cables in the pipes. Short heating cables can usually be pushed into the pipes, but longer cables may have to be pulled into the pipes (use a fish tape to feed a rope into the pipe and tie the rope to the pulling eye on the end of the heating cable). Pull on the rope from the far end of the pipe while someone else feeds/pushes the heating cable at the other end.
10. Fill the heating cable pipes with an EPA friendly glycol or a heat transfer oil ensuring that the heating cables will be completely immersed while leaving space for liquid expansion. Follow the respective manufacturer's installation recommendations to install/mix the glycol or heat transfer oil.



Important: Hangar door installations are classified as hazardous. Fill all heating cable pipes with a heat transfer liquid such as a heat transfer oil or a glycol/water mixture at this time. Heating cables must be completely immersed while allowing space for expansion of the liquid. Do not overfill pipes.

11. Check the insulation resistance of the heating cables after they has been installed in the pipes – minimum acceptable IR is 20 MΩ at 1000 Vdc.
12. Tighten the reversed glands on the heating cable cold leads into the female NPT fittings on the pipes. Refer to the torque tag on the cold lead for proper torque. In hazardous areas, it is especially important that the gland be tightened to the specified torque.
13. Ensure drainage will be adequate for run-off of melted snow and ice.
14. Insert the temperature sensor into the temperature sensor pipe. Refer to Section 4.2 for details.
15. Connect the cold leads to the junction boxes per the recommendations in Section 4 and connect the temperature controller. Excess cold lead can be coiled into a 12 in (30 cm) diameter loop (see Figure 15).
16. If using only a slab sensing temperature controller, set the controller to 40°F (5°C). If the heating cables will be controlled with an automatic snow/ice melting controller, follow the installation instructions supplied with the automatic snow/ice melting controller to install and connect the controller to the heating cables.

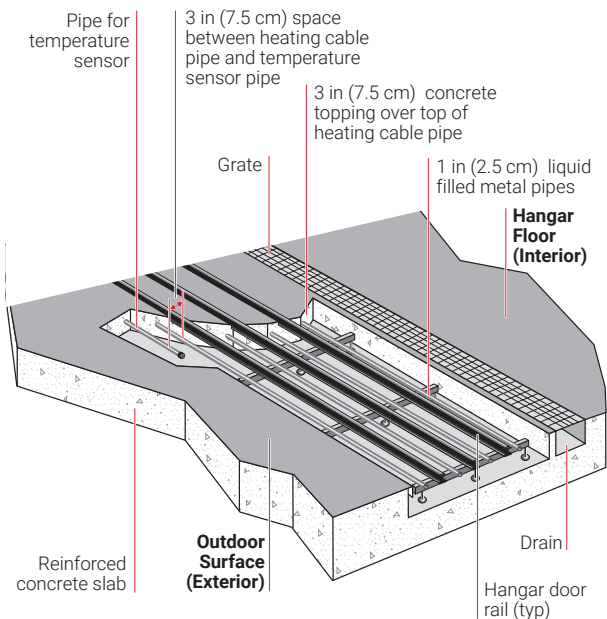

Figure 19: Typical hangar door deicing installation

3.3 Snow and Ice Melting on Exposed Surfaces

These instructions show how to install MI heating cables for snow and ice melting applications on exposed surfaces such as roofs, roof overhangs, ledges, skylights and antennas. The cables are attached to the surface using clips, clamps or tie wire. The heating cables may be exposed to contact with personnel so precautions must be taken to ensure that personnel working in the area do not contact the heating cables. Review and understand the technical requirements in Section 2 prior to installing the heating cables.

⚠ WARNING: Energized exposed heating cables are hot and can cause burns. Take precautions to ensure that personnel in the area do not contact an energized heating cable.

1. Install the junction boxes (see Section 4 for details). They should be located such that the heating cable cold leads can reach the junction box.
2. Roof snow/ice melting: Heating cables are generally attached to wire mesh elevated about 1/2 in (13 mm) above the roof surface and laid out over the area to be snow/ice melted (Figure 20). If using a mesh, attach the mesh to the roof following the requirements in the project design specifications

Antenna deicing: The heating cable is usually installed in inverted channels or tubes (pipe or conduit) welded to the antenna. Cut the tube or channel to the required length plus 12 in (30 cm) to allow for cable expansion when energized and install the tube or channel per the project design specifications. Note that the heating cable length should have been custom designed for each tube or channel.

Roof overhang deicing: Heating cables are attached to the surface to be heated using clips or clamps (Figure 22). Cables are generally used to prevent the formation of icicles at the edges of roof overhangs.

 **CAUTION:** In roof overhang and similar applications, melt water from the overhang can collect on surfaces beneath the overhang and refreeze, creating a secondary hazard.

3. Before installing the heating cable, check the insulation resistance and continuity to verify that the cable was not damaged during shipment. Details on testing can be found in Section 8. Record the results of the tests in the Heating Cable Installation Record in Section 11.
4. Roof snow/ice melting: Lay out the heating cable in a serpentine pattern and fasten the cable to the wire mesh at the predetermined spacing, ensuring the watt density is as directed in the project design specifications. For sloping roofs, it is recommended that the heating cable be installed up and down the roof (Figure 20) rather than across the roof to minimize damage to the cable from snow sliding off the roof. The heating cable can be fastened to the wire mesh using copper tie wire or straps. Do not over-tighten the copper tie wire/straps as the heating cable will expand when energized and must be allowed to move. If over-tightened, the cable may be damaged.

Cable spacing can be confirmed as follows:

$$\text{Cable Spacing (in)} = \frac{\text{Heated Area (ft}^2\text{)} \times 12}{\text{Heating Cable Length (ft)}}$$

$$\text{Cable Spacing (cm)} = \frac{\text{Heated Area (m}^2\text{)} \times 100}{\text{Heating Cable Length (m)}}$$

 **Important:** If the cable is damaged during installation, the insulation resistance will immediately decrease – check cable with the megohmmeter. If damaged, protect the damaged section from moisture with several layers of PVC tape. Installation can then continue and repairs made after the installation is complete.

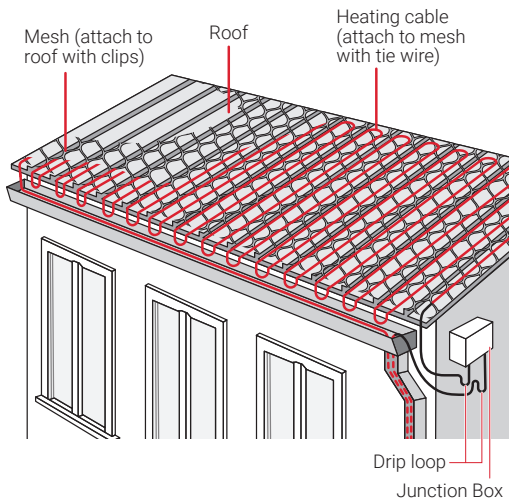

Figure 20: Typical roof snow/ice melting installation for entire roof

Antenna deicing: Install the heating cable in the tube or channel as noted in the project design specifications. Ensure that the tube or channel is long enough to allow for expansion of the heating cable. Use a clamp or bracket to keep the heating cable in place where it enters the tube or channel.

Roof overhang deicing: If snow melting the entire overhang, lay out the heating cable in a serpentine pattern, at the predetermined spacing, ensuring the watt density is as directed in the project design specifications.

The heating cable can be fastened to the surface using clips or clamps. Do not over-tighten the clips or clamps as the heating cable will expand when energized and must be allowed to move. If over-tightened, the cable may be damaged. If installing the cables to prevent icicle formation, it may only be necessary to install 4 to 6 runs of heating cables along the edges of the overhang as shown in Figure 21.

Cable spacing can be confirmed as follows:

$$\text{Cable Spacing (in)} = \frac{\text{Heated Area (ft}^2\text{)} \times 12}{\text{Heating Cable Length (ft)}}$$

$$\text{Cable Spacing (cm)} = \frac{\text{Heated Area (m}^2\text{)} \times 100}{\text{Heating Cable Length (m)}}$$

Important: If the cable is damaged during installation, the insulation resistance will immediately decrease – check cable with the megohmmeter. If damaged, protect the damaged section from moisture with several layers of PVC tape. Installation can then continue and repairs made after the installation is complete.

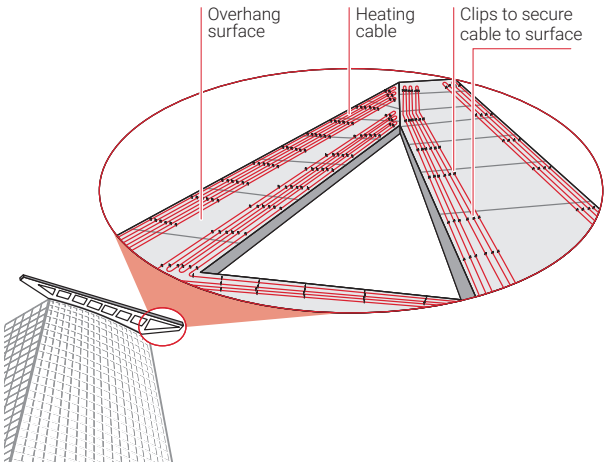

Figure 21: Typical installation to prevent icicle formation on overhang

5. Install the hot/cold joints so that they are at least 6 in (15 cm) in from the edge of the roof or overhang, or inside the tube or channel if this is an antenna deicing installation. If the cold leads are low to the ground and may be contacted by personnel in the area, protect them from damage by running them through nonmetallic conduit.
6. After installation, visually inspect the heating cables, cold leads, and junction boxes (see Section 2.10) and record the results in the Heating Cable Installation Record in Section 11.
7. Before connecting the heating cables, check the insulation resistance and continuity of all cables to verify that the cables were not damaged during installation. Details on testing can be found in Section 8. Minimum acceptable IR is 20 M Ω at 1000 Vdc. Record the results of the tests in the Heating Cable Installation Record in Section 11.
8. Connect the cold leads to the junction boxes per the recommendations in Section 4.
9. Roof snow and ice melting/roof overhangs: Use an ambient sensing temperature controller or automatic snow/ice melting controller as per project design specifications to control the heating cables. If using only an ambient sensing temperature controller, set the controller to 40°F (5°C). If the heating cables will be controlled with an automatic snow/ice melting controller, follow the installation instructions supplied with the automatic snow/ice melting controller to install and connect the controller to the heating cables. Antenna deicing: Use an ambient sensing temperature controller or timer to control the heating cables. Set temperature controller to 40°F (5°C).

3.4 Frost Heave Protection for Cryogenic Storage Tanks

Heating cables are installed inside conduit or pipe embedded in the concrete below the cryogenic tank, such as LNG, LPG (propane, butane, ethylene), or ammonia storage tank, to prevent the soil under the tank from freezing.

Freezing of the soil below the cryogenic tank can cause the concrete base to heave, possibly rupturing the tank and creating a critically hazardous situation.



Important: Reinforcement is necessary to ensure that the concrete is structurally sound. Concrete that cracks, crumbles, or settles can damage the heating cable and create a hazardous situation. The reinforcement must be adequately supported so that it is not disturbed by the installation.



Important: Verify that the appropriate hazardous area requirements are marked in the “Hazardous Location” section of the metal tag attached to the cold lead and follow all applicable electrical codes and standards for installation in hazardous areas. Junction boxes, conduit, conduit fittings, pipe, pipe fittings and bonding jumpers must be approved for the area classification.

1. Heater conduits/pipes are shorter near the outer diameter of the cryogenic tank. The conduits/pipes are generally spaced 2 ft to 4 ft (0.6 m to 1.2 m) apart and will be longest near the center of the tank (see Figure 23). Two conduits/pipes of each length will be required to completely protect the cryogenic tank. Heating cables are custom designed for each pair of conduits/pipes based on the length, therefore it is critical that the installer follow the project design specifications during preparation and installation.
2. The illustration in Figure 22 is typical of the preparation for the conduits/pipes and related fittings required for installation of the heating cables. Cut and prepare the conduit/pipes as directed in the project design specifications. One end must be capped and sealed so that it is air tight. The other end, where the heating cable will be inserted, must be prepared with a female 3/4 in or 1 in NPT fitting, as required, to accept the male 3/4 in or 1 in NPT fitting (Reversed Gland) on the heating cable cold lead (see Figure 1 in Section 1). Ensure that the conduit/pipe and fittings all have the proper agency approvals for hazardous areas.
3. Install the conduits/pipes for the heating cables, at the prescribed spacing, on a structurally sound concrete base capable of supporting the load exerted by the weight of the cryogenic tank (Figure 23).
4. Install the conduit/pipe for the slab temperature sensor midway between two of the heating cable conduits/pipes, preferably close to the center of the tank. Ensure that the end which will be embedded in the concrete is sealed. Check that the temperature sensor will fit past any bends in the conduit/pipe.



Note: Do not install the temperature sensor at this time.

5. Visually inspect the heating cable conduits/pipes and the temperature sensor conduit/pipe for damage and to make sure that the far ends are completely sealed.
6. Cover the heating cable conduits/pipes with concrete as per the requirements in the project design specifications.
7. Install rigid insulation/cellular insulation, vapor barrier, etc. per the requirements in the project design specifications.

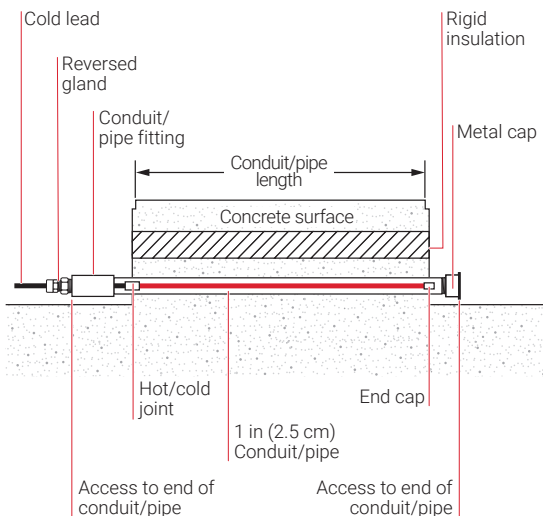
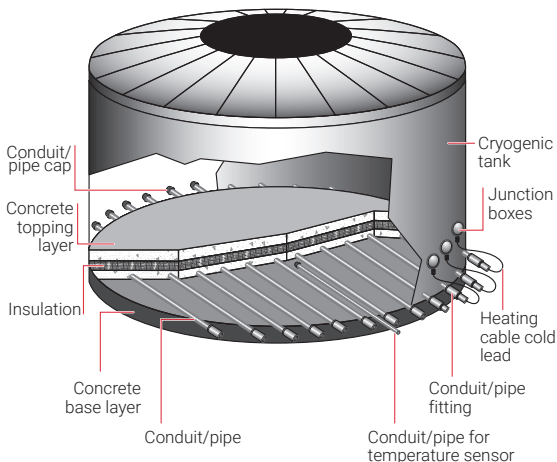

Figure 22: Typical simplified pipe installation for cryogenic tanks

8. Pour the concrete topping to the thickness specified in the project design specifications. The concrete cover over the heating cables must be reinforced and structurally sound to prevent damage from the weight of the cryogenic tank.
9. Allow the concrete to cure following the specifications in the project design specifications.
10. After the cryogenic tank has been constructed, install the junction boxes and temperature controller close to the point where the heating cables will be inserted into the conduits/pipes (Figure 23 shows a typical installation). The junction boxes must be close enough to allow the heating cable cold leads to reach them.
11. Before installing the heating cables, check the insulation resistance and continuity to verify that the cables were not damaged during shipment. Details on testing can be found in Section 8. Record the results of the tests in the Heating Cable Installation Record in Section 11.
12. Install the heating cables in the conduits/pipes. Short heating cables can usually be pushed into the conduits/pipes, but longer cables may have to be pulled into the conduits/pipes from the opposite end (use a fish tape to

feed a rope into the conduit/pipe and tie the rope to the pulling eye on the end of the heating cable).

13. Check the insulation resistance of the heating cables after they has been installed in the conduits/pipes to make sure they were not damaged during installation – minimum acceptable IR is 20 MΩ at 1000 Vdc.
14. Tighten the reversed glands on the heating cable cold leads into the female NPT fittings on the conduits/pipes. Refer to the torque tag on the cold lead for proper torque. In hazardous areas, it is especially important that the glands be tightened to the specified torque.
15. Insert the temperature sensor from the temperature controller into the temperature sensor conduit/pipe. Refer to Section 4.2 for details.
16. Connect the cold leads to the junction boxes per the recommendations in Section 4 and connect the temperature controller.
17. Set the temperature controller to the temperature indicated in the project design specifications.



Note: Junction boxes, conduit, conduit fittings, pipe, pipe fittings and bonding jumpers must be approved for the area classification.

Figure 23: Typical cryogenic tank installation (simplified)

3.5 Tubular Heater Installation for Dam Gates

These instructions cover the installation of MI tubular heaters used to allow mechanical operation of dam gates by preventing ice formation at the gates. Review and understand the technical requirements in Section 2 prior to installing the tubular heaters.

These are rugged Alloy 825 sheath heaters with welded joints, but the following additional handling guidelines are recommended:

- Do not bend the heating element to a radius less than 15 times the outside diameter of the element. Do not bend the cold lead to a radius less than 6 in (15 cm); make all bends by hand and gently curve.
- Do not bend within 6 in (15 cm) of the hot/cold joint or the end cap (see Figure 24).
- Do not alter the length of the tubular heater.
- Do not energize the tubular heater before installation is complete.
- Do not install tubular heaters where combustible materials are present.
- Follow the recommendations in Section 4 to connect tubular heaters to junction boxes.
- Where the heater loading exceeds 250 Watts/foot (820 Watts/meter), the heated length must be completely immersed in a heat conducting liquid (such as a glycol/water mixture or heat transfer oil).
- Keep cold lead termination dry before and during installation.

 **Important:** Tubular heaters must be handled and installed carefully.

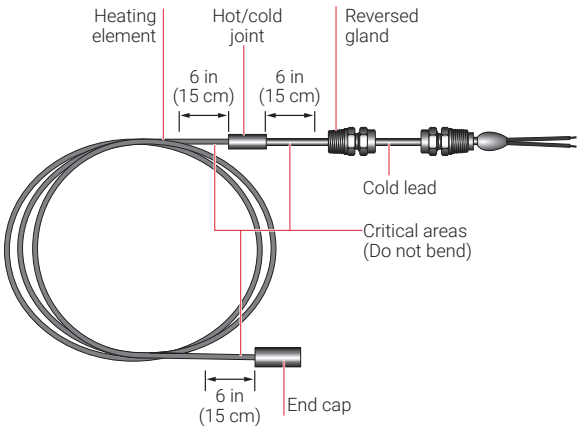



Figure 24: Typical tubular heater

 **WARNING:** Fire and shock hazard. To minimize the danger of fire from sustained electrical arcing if the heating cable is damaged or improperly installed, and to comply with Chemelex requirements and national electrical codes, ground-fault equipment protection must be used on each tubular heater branch circuit. Arcing may not be stopped by conventional circuit breakers.

⚠ WARNING: Tubular heaters are capable of reaching high temperatures during operation and can cause burns when touched. Avoid contact when heaters are powered. Use only properly trained personnel to install and maintain tubular heaters.

⚠ WARNING: The metal covering on the tubular heaters shall be bonded to the circuit bonding conductor, but shall not be used as the circuit bonding means. Metallic structures or materials used for the support of, or on which the tubular heaters are installed, must be bonded to ground.

1. The illustration in Figure 25 is typical of the preparation required for the pipes and related fittings necessary for installation of the tubular heater. Cut and prepare the pipes as directed in the project design specifications. One end must be capped and sealed so that it is liquid tight. The other end, where the tubular heater will be inserted, must be prepared with a female 3/4 in or 1 in NPT fitting, as required, to accept the male 3/4 in or 1 in NPT fitting (Reversed Gland) on the tubular heater cold lead (see Figure 1 in Section 1). A threaded flange may be used instead of the threaded pipe fitting.

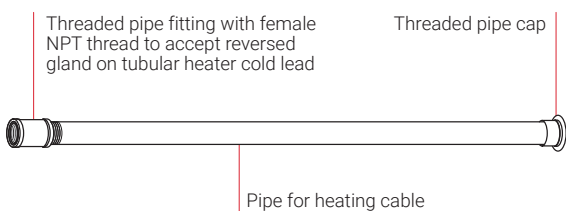

Figure 25: Typical pipe preparation for tubular heaters

2. Install the pipes for the tubular heaters and the temperature sensor per the project design specifications. Figure 26 shows a typical pipe installation for tubular heaters used in vertical dam gates.
3. Before pouring concrete, check that the pipes for the tubular heaters and the temperature controller sensor have been installed per the project design specifications.
4. Pour the concrete and allow it to cure.
5. Install the junction boxes and temperature controller close to the point where the tubular heaters will be inserted into the pipe. The junction boxes must be close enough to allow the tubular heater colds lead to reach them.
6. Before installing the heaters, check the insulation resistance and continuity to verify that the heaters were not damaged during shipment. Details on testing can be found in Section 8. Record the results of the tests in the Heating Cable Installation Record in Section 11.
7. The tubular heater weighs approximately 0.34 lb/ft (0.51 kg/m). Install the heater by hand. If the heater is lowered

down a hole, such as in dam gate applications, it is advisable to use the hole to straighten the heater as it is uncoiled by slowly inserting it a few feet at a time.



Note: Keep the cold lead coiled until the heated length is lowered into position and then uncoil the cold lead by hand.

8. If called for in the project design specifications, fill the pipe with an EPA friendly glycol or a heat transfer oil ensuring that the tubular heater will be completely immersed while leaving space for liquid expansion. Follow the respective manufacturer's installation recommendations to install/mix the glycol or heat transfer oil.
9. Support the heater from the cold lead using an appropriate support method (such as the optional reversed gland, if supplied). Do not use the 3/4 in NPT termination gland assembly to support the heater.

If the tubular heater was supplied with the optional "mounting gland assembly" (reversed gland), screw the gland into the NPT fitting on the pipe and tighten to the recommended torque. This gland will support the weight of the heater.

10. Form the cold lead to the desired shape observing the bending radius shown under the "guidelines" above and connect the 3/4 in NPT termination gland assembly to the junction box per the recommendations in Section 4.



Note: Ensure that the pot seal is positioned above the bottom of the junction box to prevent moisture from causing an electrical short.

11. Before connecting power, check the insulation resistance and continuity to verify that the heaters were not damaged during installation. Details on testing can be found in Section 8. Record the results of the tests in the Heating Cable Installation Record in Section 11.
12. Connect the heaters to the temperature controller and set controller to the desired temperature.

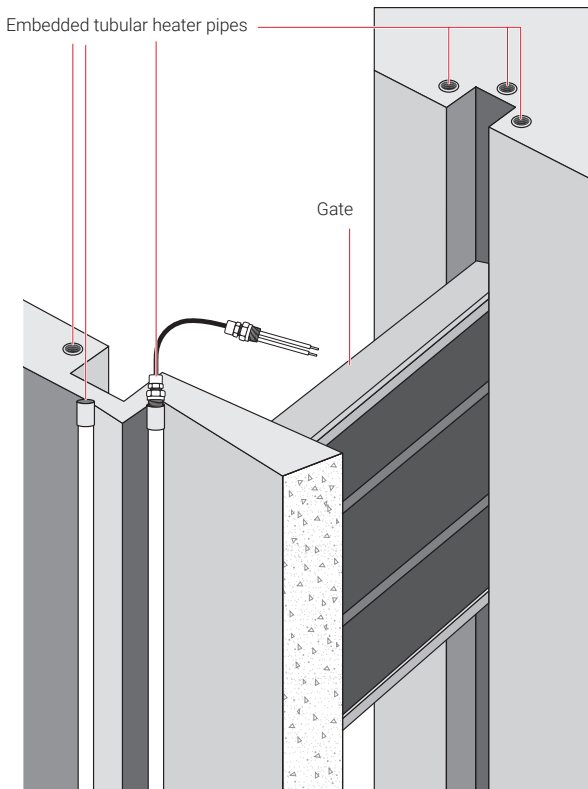

Figure 26: Typical tubular heater installation

3.6 Soil Heating

These instructions show how to install MI heating cables in soil to promote the starting of plant cuttings and seed for nursery stock and flower crops in greenhouses. Review and understand the technical requirements in Section 2 prior to installing the heating cables.

1. Ensure cold frame or hotbed can accept the heating cable without causing damage to the cable. If the cold frame or hotbed is existing, it will be necessary to remove 6 in (15 cm) of soil below the final intended soil level – refer to Figure 27
2. Make sure that the cold frame or hotbed has adequate drainage. If not, remove an additional 3 in (7.5 cm) of soil and replace with sand or coarse gravel.
3. Level the subsoil layer that the cables will be laid on.

4. Install the junction box and temperature controller (see Section 4 for details). For single conductor heating cables, the cable layout should begin and end at or close to the junction box to allow the cold leads to be fed back to the junction box.
5. Before installing the heating cable, check the insulation resistance and continuity to verify that the cable was not damaged during shipment. Details on testing can be found in Section 8. Record the results of the tests in the Heating Cable Installation Record in Section 11.
6. Install heating cable on subsoil layer; start with the heating cable cold lead close to the junction box or temperature controller (Figure 27). Install the cable in a serpentine manner at the specified cable spacing taking care not to damage the heating cable. If using a "B" configuration heating cable, finish with the opposite end of the cold lead back at the junction box. Closer spacing at the outside edges will help to provide more uniform heating.

Cable spacing can be confirmed as follows:

$$\text{Cable Spacing (in)} = \frac{\text{Heated Area (ft}^2\text{)} \times 12}{\text{Heating Cable Length (ft)}}$$

$$\text{Cable Spacing (cm)} = \frac{\text{Heated Area (m}^2\text{)} \times 100}{\text{Heating Cable Length (m)}}$$

7. Install the hot/cold joints so that they are at least 6 in (15 cm) in from the edge of the soil (see Section 2 for details), ensuring that they will be completely embedded in the soil. Protect the cold leads with nonmetallic conduit where they emerge from the soil.
8. Visually inspect the heating cable, cold leads, and junction box (see Section 2.10) and record the results in the Heating Cable Installation Record in Section 11.
9. Before covering the heating cable, check the insulation resistance and continuity of the heating cable to verify that the cable was not damaged during installation. Details on testing can be found in Section 8. Minimum acceptable IR is 20 MΩ at 1000 Vdc. Record the results of the tests in the Heating Cable Installation Record in Section 11.



Important: If the cable is damaged during installation, the insulation resistance will immediately decrease – check cable with the megohmmeter. If the cable was damaged, the installation should be stopped and repairs made to the heating cable before continuing with the installation.



Important: Take precautions to protect the heating cable during installation. Do not use sharp tools such as rakes, shovels, etc. that might damage the heating cable. Do not strike the heating cable with tools, walk on the heating cable, or do

anything else that will damage the heating cable. Further details can be found in Section 2.

10. Cover the heating cable with 2 in (5 cm) of soil or sand making sure that the heating cable is thoroughly embedded in the soil/sand. Make sure that the heating cable is not damaged by sharp tools such as rakes, shovels, etc.
11. Install hardware cloth over the 2 in (5 cm) sand/soil layer – this will prevent damage to the heating cable from garden tools.
12. Install the conduit for the soil temperature sensor; it should sit about 2 in (5 cm) above the hardware cloth. If necessary, place 2 in (5 cm) of soil, by hand, below the conduit to keep it elevated above the hardware cloth (see Figure 27 for details). Installing the temperature sensor in metal or plastic conduit will protect it from damage by garden tools. Before covering with soil, check that the temperature sensor will fit past the bend in the conduit.



Important: Do not install the temperature sensor at this time.

13. Place a minimum 4 in (10 cm) of soil planting layer over the hardware cloth.
14. Connect the cold leads to the junction box.
15. Connect the temperature controller to the heating cable and install the temperature sensor inside the conduit.
16. Set the temperature controller to 45°F (7°C). This is an ideal setting when the air temperature is 50°F (10°C) or lower.

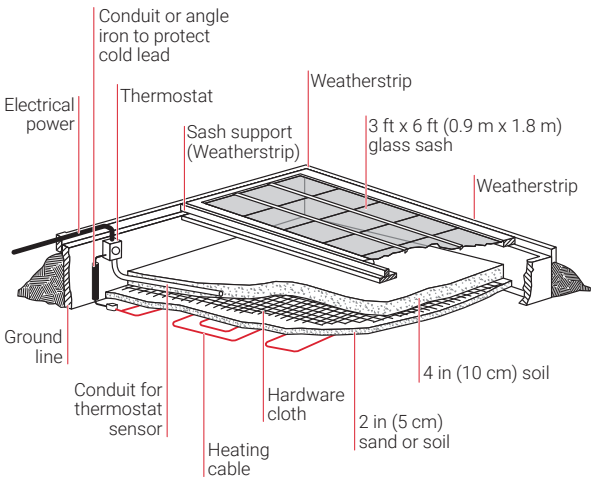

Figure 27: Typical soil heating installation

3.7 Animal Pen Floor Heating

These instructions show how to install MI heating cables in concrete floors used in animal pens. The cables are attached to the concrete base slab and covered with a minimum of 2 in (5 cm) of concrete. Review and understand the technical requirements in Section 2 prior to installing the heating cables.

Important: Reinforcement is necessary to ensure that the concrete is structurally sound. Concrete that cracks, crumbles, or settles can damage the heating cable. The reinforcement must be adequately supported so that it is not disturbed by the installation. It is important that the heating cable depth in the concrete be maintained for proper operation of the system.

1. Mark the location of control and/or expansion joints on the edge forms and on the heating cable layout drawings. Control joints may be crossed as shown in Figure 28. Avoid crossing expansion joints.

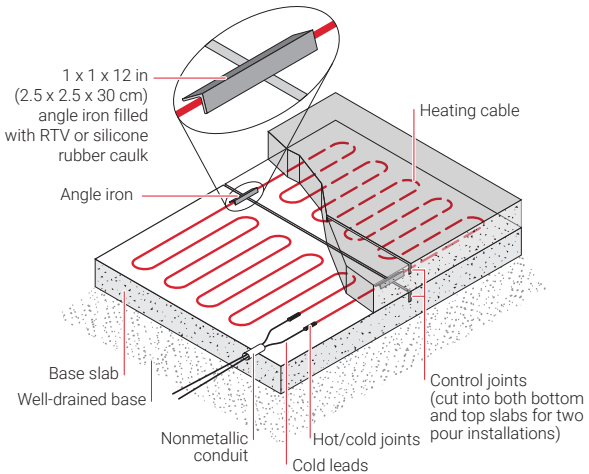

Figure 28: Crossing control joints

Important: In two-pour installations it is desirable to make the base slab and topping course truly monolithic since the majority of recorded cable damage is a result of slabs becoming delaminated and shifting. The surface of the base slab must be properly cleaned and prepared to allow the topping pour to bond to the base slab. Use an appropriate method for proper bonding or consult with the structural engineer.

2. Install the junction boxes (see Section 4 for details). For single conductor cables, the cable layout should begin and end at or close to the junction box to allow the cold leads to be fed back to the junction box.
3. Install prepunched strapping at 3 to 4 ft (0.9 to 1.2 m) intervals with additional runs, where required, to hold cable loops securely. Fasten the strapping in place using an appropriate fastening method (see Figure 30).
4. Before installing the heating cable, check the insulation resistance and continuity to verify that the cable was not damaged during shipment. Details on testing can be found in Section 8. Record the results of the tests in the Heating Cable Installation Record in Section 11.
5. Lay out the heating cable in a serpentine pattern and fasten the cable to the prepunched strapping at the predetermined spacing, ensuring the watt density is as directed in the project design specifications. It is recommended that the tabs on the prepunched strapping be bent backwards over the cable as shown in Figure 29. Typical cable spacing ranges between 3 in (7.5 cm) minimum to 7 in (18 cm) maximum on centers. Stay at least 6 in (15 cm) from edges and outer walls (see Figure 30 for details). Cross control joints as shown in Figure 28.

Cable spacing can be confirmed as follows:

$$\text{Cable Spacing (in)} = \frac{\text{Heated Area (ft}^2\text{)} \times 12}{\text{Heating Cable Length (ft)}}$$

$$\text{Cable Spacing (cm)} = \frac{\text{Heated Area (m}^2\text{)} \times 100}{\text{Heating Cable Length (m)}}$$

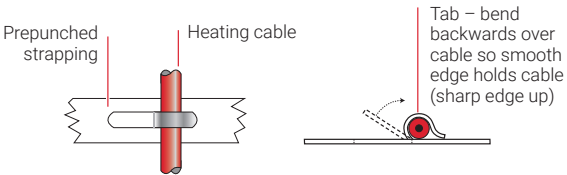

Figure 29: Method of bending tabs on prepunched strapping

Important: The heating cable spacing may have to be adjusted to ensure uniform coverage over the area to be heated.

6. Install the hot/cold joints so that they are at least 6 in (15 cm) in from the edge of the slab, ensuring that they will be completely embedded in the concrete (see Figure 7). Protect the cold leads with nonmetallic conduit where they emerge from the slab (see Figure 30).

7. Install the conduit for the slab temperature sensor between two runs of heating cable (see Section 4.2 for details). Before covering with concrete, check that the temperature sensor will fit past the bend in the conduit.



Important: Do not install the temperature sensor at this time.

8. Visually inspect the heating cables, cold leads, and junction boxes (see Section 2.10) and record the results in the Heating Cable Installation Record in Section 11.
9. Before the concrete is poured, check the insulation resistance and continuity of all heating cables to verify that the cables were not damaged during installation. Details on testing can be found in Section 8. Minimum acceptable IR is 20 MΩ at 1000 Vdc. Record the results of the tests in the Heating Cable Installation Record in Section 11.
10. Pour a minimum 2 in (5 cm) thick concrete topping over the heating cables and ensure that it is thoroughly consolidated with a high frequency vibrator. Continuously check the insulation resistance of the heating cables to verify that the cables are not damaged during the concrete pour – minimum acceptable IR is 20 MΩ at 1000 Vdc. The concrete cover over the heating cables must be structurally sound and must properly adhere to the base slab to prevent delamination between the slabs.



Important: Take precautions to protect the heating cable during the concrete pour. Do not use sharp tools such as rakes, shovels, etc. that might damage the heating cable. Do not strike the heating cable with tools, walk on the heating cable, or do anything else that will damage the heating cable. Further details can be found in Section 2.



Important: If the cable is damaged during the concrete pour, the insulation resistance will immediately decrease – check with the megohmmeter. The pour should be stopped and a small wooden box built around the damaged section. Pouring can then continue and repairs made after the concrete sets up.

11. Allow the concrete to cure following the specifications in the contract documents. Do not energize the heating cables during the curing period. Do not allow traffic on the new completed surface until adequate stability has been attained and the material has cured sufficiently.



Important: Use caution when saw cutting the control joints to avoid damaging the heating cables. Consult with the electrical contractor or cable installer before cutting or drilling to find out cable depth.

12. Connect the cold leads to the junction box and connect the temperature controller.
13. Install the slab temperature sensor in the conduit. Refer to Section 4 for details.

14. Set the temperature controller to the temperature specified in the contract documents or as required to maintain the floor at a temperature that is comfortable for the livestock.

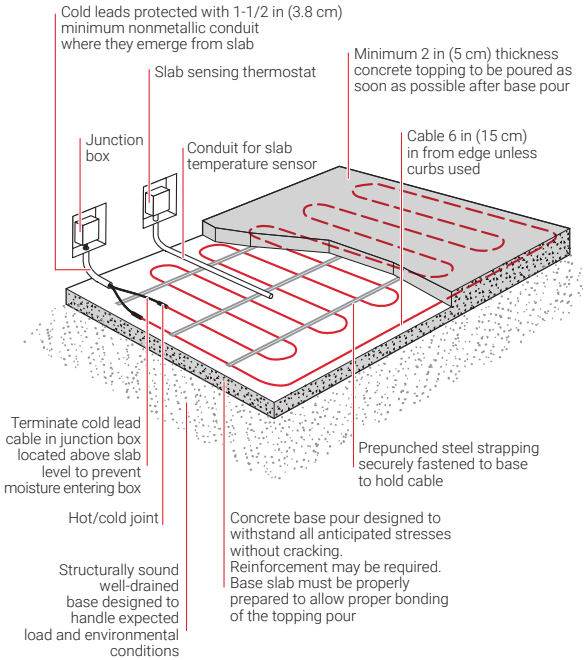

Figure 30: Heating cable installation for animal pen floors

4. ACCESSORY INSTALLATION

4.1 Junction Boxes

MI heating cables must be connected to UL Listed or CSA Certified junction boxes suitable for the area classification (hazardous, wet, etc). Metallic junction boxes with threaded entries are recommended since the NPT threaded connector (see Figure 1) provides a ground path for the cable sheath when tightened to the recommended torque. In hazardous areas, the NPT threaded connector also prevents the passage of gases, vapors, liquids and flames.

Nonmetallic junction boxes may also be used but a means of grounding the NPT gland connector is required. For nonmetallic junction boxes without a grounding/earthing plate, a grounding kit, available from Chemelex (see Figure 31) can be connected into each entry hole. Figure 34 shows a MI heating cable connected into a nonmetallic junction box using the grounding kit.

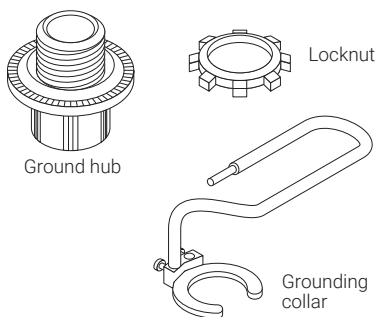

Figure 31: Typical ground hub for non-metallic junction box without grounding/earthing plate

If the nonmetallic junction box is supplied with a grounding/earthing plate (see MIJB-864-A and MIJB-1086-B in Section 10), the NPT gland connector can be connected into a threaded hub (see Figure 32) available from major electrical retailers.

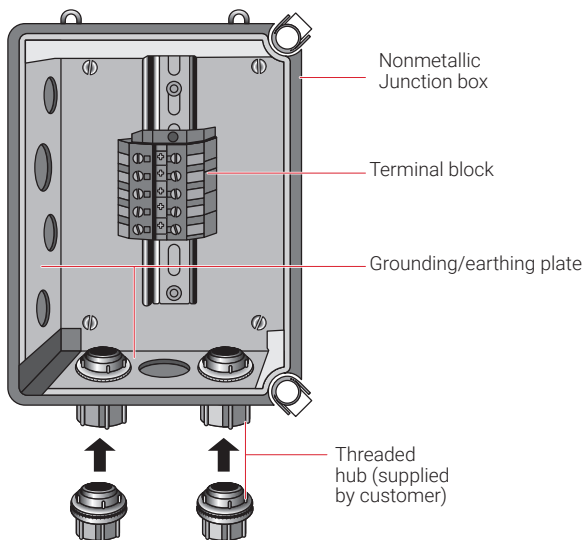

Figure 32: Typical nonmetallic junction box with grounding/earthing plate

Ground hubs should be sized to suit the NPT gland connector supplied on the heating cable cold lead. Make sure that the non-metallic junction box, ground hubs and reducers are suitable for the area classification (hazardous, wet, etc).

Note: If installing the heating cable in a hazardous area, ensure that the junction boxes are also approved for the area where the heating cables will be installed.

Important: Ensure that the heating cable sheath is properly grounded. This can be accomplished by connecting the cold lead into a metallic junction box with threaded entries and tightening the gland connector to the recommended torque. When connecting heating cables to nonmetallic junction boxes, ensure that the heating cable sheaths are properly grounded by following the instructions in this section.

Junction box installation details

Improper location of junction boxes can cause heating cable failure. Avoid problems by:

- Installing the heating cable cold leads and/or conduit leading to the junction box so that water does not enter the box.
- Not embedding the junction box in the concrete slab or too low to the ground as this may allow moisture to enter the junction box, resulting in cable failure; mount junction boxes above grade level, inside the building, or on a structure wall, if possible.

- Not entering the junction box from the top as this may allow water to enter the box.
- Taking appropriate measures to ensure that moisture does not collect in the bottom of the junction box. Moisture, due to condensation, may form in the box even after the lids have been installed.

For metal junction boxes with threaded entries (Figure 33), insert the heating cable tails through the threaded entry and tighten the threads of the NPT gland connector into the junction box (if required, screw a reducer into the threaded entry).

When using nonmetallic junction boxes, a means to ground the NPT gland connector is required. For nonmetallic junction boxes without a grounding/earthing plate, the NPT gland connector can be threaded into a ground hub kit as shown in Figure 31 and Figure 34 – this kit is available from Chemelex. If the nonmetallic junction box is supplied with a grounding/earthing plate, the NPT gland connector can be connected into a threaded hub (see Figure 32) available from major electrical retailers.

Install the cold lead “pot” so that it extends about 2 in (5 cm) above the bottom of the junction box (see Figure 33 and Figure 34). Tighten the compression nut on to the cold lead to the torque setting indicated on the tag attached to the gland connector. This ensures that the cable sheath is properly grounded and prevents the passage of gases, vapors, liquids, and flames in hazardous areas.

Connect the heating cable tails and distribution power wires to the terminal block (see typical junction box wiring diagrams in Section 6). Install the junction box lid and make sure it is watertight. Check to make sure that unused entries in the junction box are sealed with hole plugs.



Important: Minimize handling the tails to avoid breakage.

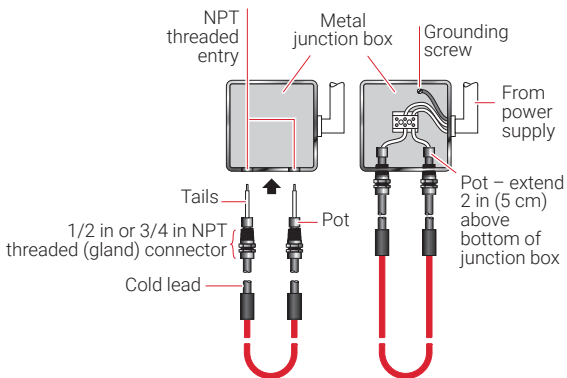

"B" configuration

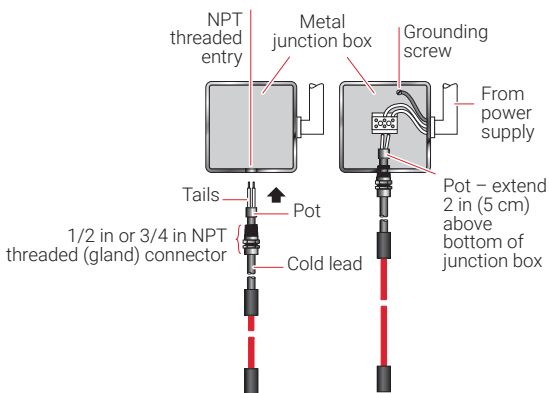

"D" or "TH" configuration

Figure 33: Metal junction box with NPT threaded entries

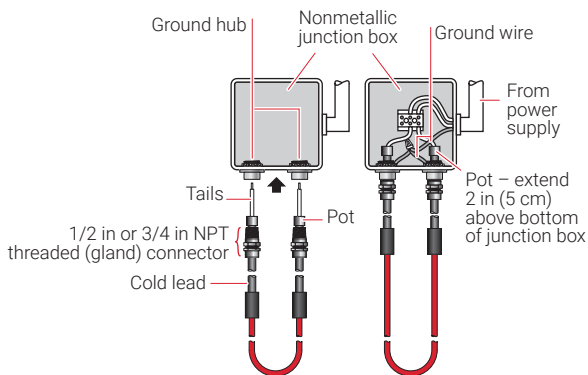

"B" configuration

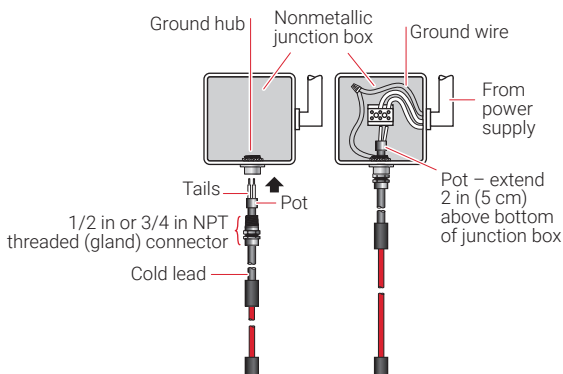

"D" or "TH" configuration

Figure 34: Nonmetallic junction box with ground hubs

Cold lead installation guidelines

- For embedded heating cables, plan the location of the junction box so that the cold leads can reach the box without crossing expansion joints. If the cold leads must cross an expansion joint, contact Chemelex for assistance.
- Do not feed the cold leads through metal conduit of any kind.
- If the cold leads are run exposed on exterior walls or supports, prevent damage from vehicles and vandalism by protecting them with a metal guard.
- Coil excess cold lead into a 12 in (30 cm) or larger diameter loop and attached to a support close to the junction box.

4.2 Temperature Controller Installation

For applications where the slab or soil must be maintained at a specified temperature, mount the enclosure on a wall (Figure 35) close to the conduit which was installed during the heating cable installation (Section 3). Insert the sensor into the conduit far enough out into the area being heated so that it will sense the temperature at approximately the middle of the area. Set the temperature as specified in the design documentation.

For roof deicing applications, an automatic snow/ice melting controller is recommended. This will provide the most energy efficient form of control. If using only an ambient sensing temperature controller, the sensing bulb should be located in such a manner as to sense air temperature. Set the temperature between 40°F to 50°F (5°C to 10°C).

- Mount temperature controller above grade level and in an area where it will not be damaged by vehicles or vandalism.
- Cable or conduit leading to temperature controller must be installed so that water does not enter the enclosure.
- Make sure temperature controller lid is watertight.

 **Important:** The temperature controller enclosure must be suitable for the area classification (wet area, hazardous area, etc.).

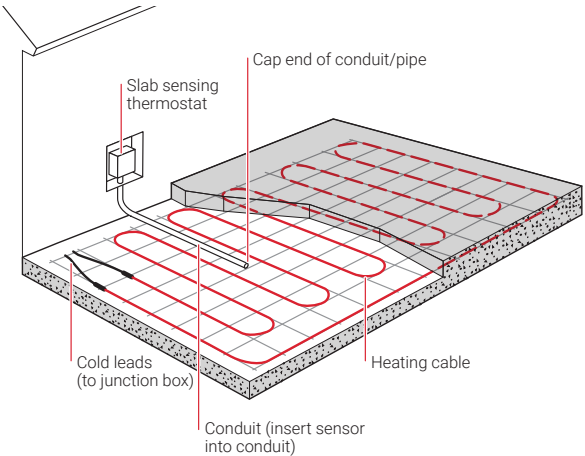

Figure 35: Slab/soil temperature controller installation

5. CONTROL, MONITORING AND POWER DISTRIBUTION

The MI Heating Cable System may be controlled using one of the following three options. For snow/ice melting and roof deicing applications, the automatic snow controller offers the highest system reliability and the lowest operating cost. For soil heating, animal pens, frost heave protection and dam gate applications, the slab sensing temperature controller is recommended as these applications require the slab/soil be kept at a specified temperature regardless of weather conditions.

The three control methods commonly used with these MI Heating Cable Systems are:

- Manual on/off control
- Ambient/soil/slab sensing temperature controller
- Automatic snow controller

If the current rating of the control means is exceeded, all three methods will require contactors sized to carry the load. For snow/ice melting and roof deicing, each method offers a tradeoff balancing initial cost versus energy efficiency and ability to provide effective snow/ice melting; if the system is not energized when required, snow and ice will accumulate. If the system is energized when it is not needed, there will be unnecessary power consumption. For additional information refer to Section 6, or contact your Chemelex representative for details.

5.1 Manual On/Off Control

Under manual control, recommended only for small areas, a manual on/off switch operates the power contactor. In some installations, the system may be controlled directly by manually operating the circuit breakers.

5.2 Temperature Controller

A temperature controller may be used for all applications covered in this installation manual. For soil heating, animal pens, frost heave protection and dam gate deicing applications, a temperature controller, with the sensing element placed in the soil/slab, must be used to maintain the medium at the specified temperature. For snow/ice melting and roof deicing applications, the temperature controller can be used to energize the heating system whenever the temperature falls below freezing, but is not very energy efficient when used as the sole means of control as the heating cables will cycle on and off even when precipitation is not present.

5.3 Automatic Snow/Ice Melting Controller

This control method, Figure 36, automatically energizes the heating cables when precipitation and low temperature are detected. For snow/ice melting applications, the integral slab

temperature sensor de-energizes the heating cables after the slab reaches the controller set-point, even if freezing precipitation is still present. For roof deicing applications, the heating cables are de-energized when moisture is no longer present in the gutter. A built-in timer keeps the system energized for a set hold-on time to allow the slab or gutter to completely dry once precipitation stops. This is the most energy efficient control solution.

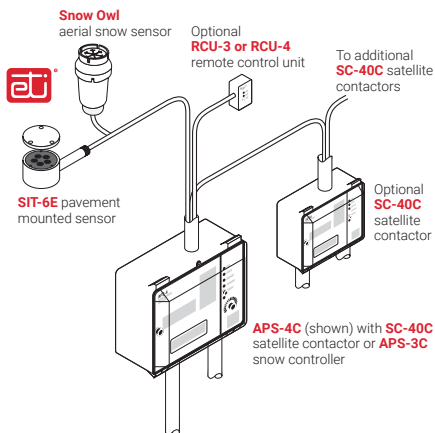

Figure 36: Automatic snow/ice melting control system

6. POWER SUPPLY AND ELECTRICAL PROTECTION

6.1 Voltage Rating

Check the incoming electrical supply to verify that the voltage to be connected to the heating cable is correct. The heating cable voltage rating is printed on the metal tag attached to the cold lead. For a Wye connected three-phase system, the heating cable voltage rating printed on the metal tag will equal the line-to-line supply voltage divided by the square root of 3 ($V_{L-L} / \sqrt{3}$). For some applications, the heating cables may have been designed to be connected in series. For these rare instances, where the heating cables are series connected, the sum of the voltages shown on the cable tags should equal the supply voltage.

6.2 Circuit Breaker Sizing

Size circuit breakers according to electrical code requirements. Single-phase connected heating cables require single-pole circuit breakers if one leg of the circuit will be wired to neutral, otherwise two-pole breakers are required. For three-phase connected heating cables, 3-pole circuit breakers are required. Generally, heating cable current draw, supply voltage, and wiring configuration are required to size circuit breakers. Refer to the

heating cable tag for the electrical characteristics of the heating cable.

The minimum breaker size may be determined as follows:

Single phase circuit

For single phase connected heating cable circuit, the minimum breaker size can be calculated using the follow formula:

Breaker size = Heating cable current* x 1.25

Balanced three-phase circuit

For a Delta connected heating cable circuit, the minimum breaker size can be calculated using the following formula:

Breaker size = Heating cable current* x $\sqrt{3}$ x 1.25

For a Wye connected heating cable circuit, the minimum breaker size can be calculated using the follow formula:

Breaker size = Heating cable current* x 1.25

* Heating cable current = Watts/Voltage (see cable ID tag)

6.3 Ground-Fault Equipment Protection

Use circuit breakers with 30 mA ground-fault protection on all heating cable circuits. If commercially available ground-fault circuit breakers are unavailable for the voltage and current rating of the circuit, ground-fault protection may be accomplished using a shunt trip breaker and ground-fault sensor (see Figure 43 and Figure 44). For snow/ice melting and roof deicing applications, an Raychem SMPG series power distribution and control panel is available.

Ground-Fault Equipment Protection (GFEP) is required for all heating cable installations to prevent arcing or fire if the cable is improperly installed or damaged. To minimize the risk of fire, Chemelex and national electrical codes require both ground-fault protection of equipment and a grounded metallic covering on all heating cables.

 **WARNING:** To minimize the danger of fire from sustained electrical arcing if the heating cable is damaged or improperly installed, and to comply with Chemelex requirements, agency certifications, and national electrical codes, ground-fault equipment protection must be used on each heating cable branch circuit. Arcing may not be stopped by conventional circuit protection.

 **WARNING:** To prevent shock or personal injury, disconnect all power before making connections to the heating cable.

6.4 Junction box Wiring

Typical junction box wiring for a single-phase connected heating cable is shown in Figure 37. Balanced three-phase connected heating cables (cables are the same voltage and wattage) are shown in Figure 38 and Figure 39. In the delta

connected circuit shown in Figure 38, the three heating cables are connected to a single junction box, but could be connected to individual junction boxes and three-phase connected at the contactor.

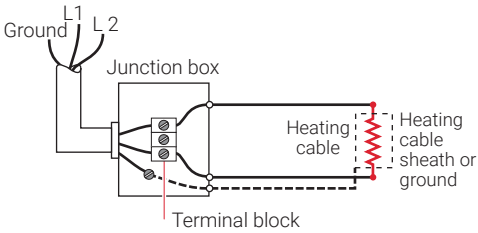

Figure 37: Typical 1Ø connection

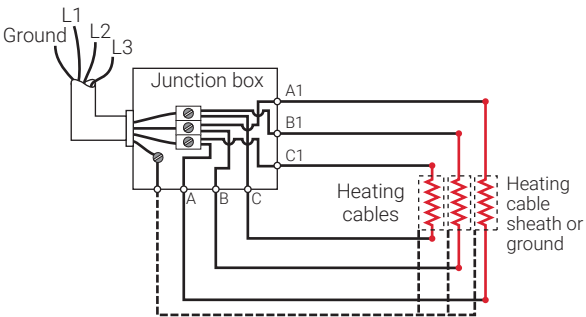

Figure 38: Typical 3Ø Delta connection

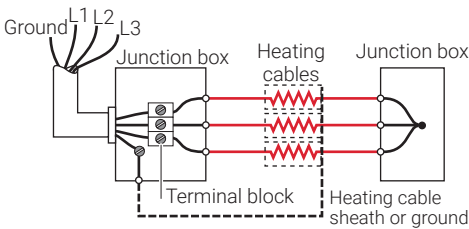

Figure 39: Typical 3Ø Wye connection

6.5 Typical Wiring Diagrams

Typical single and three phase wiring diagrams using only an ambient sensing or slab temperature controller are shown in Figure 40 to Figure 44. Use a contactor, as shown in Figure 42 to Figure 44, when switching loads greater than the maximum current or voltage rating of the temperature controller. Follow all requirements of national and local electrical codes when connecting heating cables and controllers.

When connecting heating cables in a three-phase Delta configuration, the heating cable voltage must equal the line-to-line supply voltage; e.g., on a 480 volt, three-phase supply, the heating cable voltage must equal 480 volts. When connecting heating cables in a Wye configuration, the heating cable voltage must equal the line-to-neutral supply voltage; e.g., on a 480 volt, three-phase supply, the heating cable voltage must equal 277 volts.

For wiring configurations outside the scope of this manual, please contact your Chemelex representative for assistance.

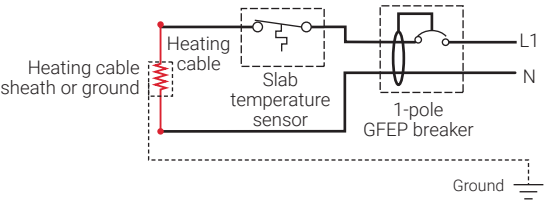

Figure 40: Control of heating cable on 1Ø line-to-neutral supply using temperature controller

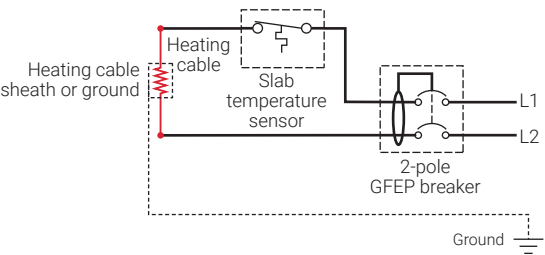

Figure 41: Control of heating cable on 1Ø line-to-line supply using temperature controller.

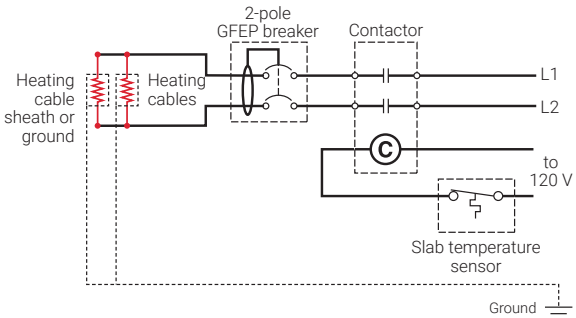

Figure 42: Control of parallel connected heating cables with contactor on 1Ø line-to-line supply using temperature controller

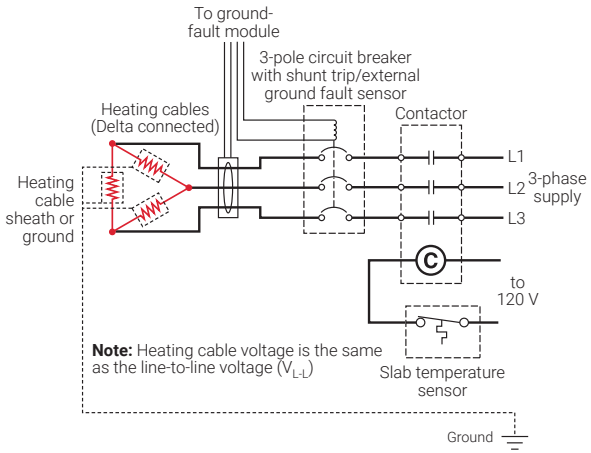

Figure 43: Control of balanced 3Ø Delta connected heating cables with contactor using temperature controller

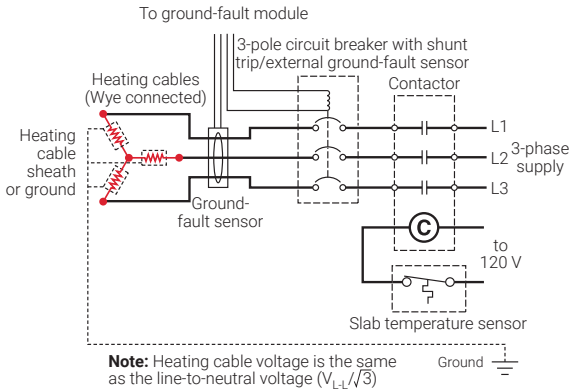

Figure 44: Control of balanced 3Ø Wye connected heating cables with contactor using temperature controller

7. COMMISSIONING AND PREVENTATIVE MAINTENANCE

Chemelex requires that a series of commissioning tests be performed on the system. These tests are also recommended annually for preventive maintenance. Results must be recorded and maintained for the life of the system utilizing the Heating Cable Installation Record in Section 11. Submit this manual with initial commissioning test results to the owner.

7.1 System Tests

A brief description of each test is found below. Detailed test procedures are found in Section 8.

Visual Inspection

Inspect all wiring for conformance to design drawings and applicable codes. Inspect the junction boxes, cable terminations, and connections to the cable for physical damage. Inspect the cold leads from the point where they exit the installation area to the junction boxes for physical damage. Check that moisture is not present in the junction boxes, that electrical connections are tight, and that the NPT threaded connectors are tight and properly grounded.



Note: Damaged cold leads and terminations must be repaired or replaced.

Continuity and insulation resistance

Continuity and insulation resistance (IR) testing is recommended at four stages during the installation process, as part of regular system inspection, and after any maintenance or repair work. Continuity testing checks the integrity of the resistive heating element inside the heating cable. IR testing checks the integrity of the electrical insulating barrier between the resistive heating element and the cable sheath. IR testing can also be used to isolate the damage to a single run of heating cable. Fault location can be used to further locate damage.

Snow/ice melting controller

Test the functioning of the controller by following the instructions supplied by the manufacturer.

Power check

The power check is used to verify that the system is generating the correct power output. This test can be used in commissioning to confirm that the circuit is functioning correctly. For ongoing maintenance, compare the power output to previous readings. The heating cable power output (watts) is printed on the identification tag attached to the heating cable.

Energize the circuit breaker and measure the heating cable current using a clamp-on or in-line ammeter. Measure the

voltage across the heating cable using a volt meter. Calculate the heating cable wattage using the measured voltage and current.

The calculated wattage can be compared to the wattage indicated on the heating cable tag. This gives a good indication of heating cable performance.

Ground-fault test

Test all ground-fault breakers per manufacturer's instructions.

7.2 Preventative Maintenance



Important: De-energize all circuits that may be affected during maintenance work.

Maintenance Records

The Maintenance Log Record in Section 11 should be filled out during all inspections and kept for future reference.

Repairs

Use only Raychem MI cable and components when replacing any damaged cable. Repairs should be performed only by qualified personnel and to Chemelex requirements. Retest the system after all repairs or replacements.



WARNING: Damage to cables or components can cause sustained electrical arcing or fire. Do not energize cables that have been damaged. Repair or replace damaged heating cable or terminations before energizing the circuit.

8. TEST PROCEDURES

This section describes the test procedure for heating cables when they are received, during installation, at commissioning and during any maintenance or repair work.

8.1 Visual Inspection

- Inspect all wiring for conformance to applicable codes.
- Check circuit breaker sizing for each circuit to make sure it is suitable for the circuit current and voltage.
- Verify that the contactor coil operating voltage is correct for the control device used.
- Verify electrical wiring for the heating cables and temperature control system. Check that moisture and corrosion are not present and that electrical connections are tight.
- Verify temperature controller sensor is correctly installed, capillary or sensor lead is not damaged and ensure that temperature controller is operational and set to the temperature indicated in the project specifications.
- Visually inspect junction boxes, cold leads, terminations, and electrical connections to the cable for physical damage. Repair or replace damaged cable and terminations.
- Verify that the cable glands are correctly fitted into junction boxes, and are tight and properly grounded.
- Check that no moisture is present in junction boxes and that electrical connections are tight.
- Verify that all junction boxes are appropriate for the area classification and are properly sealed.

8.2 Insulation Resistance Test – Test 1

Insulation resistance is measured between the heating cable sheath and the tails. Chemelex recommends that the insulation resistance test be conducted at, but not exceeding 1000 Vdc, however in the absence of equipment with this capability, a 500 Vdc test is suitable to detect most installation related concerns.

Frequency

Insulation resistance testing is recommended at four stages during the installation process and as part of regularly scheduled maintenance.

- When received – minimum 100 M Ω
- After the cables have been installed – minimum 20 M Ω
- Continuously during placement of concrete, soil, etc. – minimum 20 M Ω
- Prior to initial start-up (commissioning) – minimum 20 M Ω *
- As part of the regular system inspection
- After any maintenance or repair work

* Under adverse weather conditions, or when the tails or terminal connections have evidence of moisture, lower

insulation resistances may be encountered. Wipe tails, face of pot, and all terminal connections with a clean dry rag to eliminate moisture and retest.

Test Criteria

The minimum insulation resistance for a clean, dry, properly installed heating cable should reflect the values shown above, regardless of the heating cable length.

8.3 Continuity (Resistance) Test – Test 2

Continuity testing is conducted using a standard Digital Multimeter (DMM) and measures the resistance between the cold lead tails. This test should also be done after any maintenance or repair work.

Test Criteria

Measure the resistance of the MI heating cable with the DMM. Most MI heating cable resistances are less than 100 ohms. The approximate resistance can be calculated using the formula: Resistance (ohms) = Volts² / Watts. Voltage and wattage are printed on the heating cable identification tag.

8.4 Insulation Resistance and Continuity Test Procedure

1. De-energize the circuit.
2. Disconnect the heating cable tails from supply wires or terminal block.
3. Set megohmmeter test voltage to 0 Vdc or off.
4. Connect the positive (+) lead to the heating cable sheath (Figure 45).
5. Connect the negative (–) lead to both heating cable tails simultaneously.



Important: In cases where the opposite end of the heating cable does not terminate in the same junction box, it must be disconnected from the power supply or series connected heating cable and kept isolated from surrounding metal objects to avoid erroneous readings.

6. Turn on the megohmmeter and set the voltage to 1000 Vdc; apply the voltage for 1 minute. Meter needle should stop moving. Rapid deflection indicates a short. Record the insulation resistance value in the Heating Cable Installation Record in Section 11.
7. Turn off the megohmmeter.
8. If the megohmmeter does not self-discharge, discharge phase connection to ground with a suitable grounding rod. Disconnect the megohmmeter.
9. Check the continuity (resistance) of the heating cable between the two tails (Figure 45). Record the resistance value in the Heating Cable Installation Record in Section 11.

10. Disconnect the multimeter.
11. Reconnect heating cable tails to the supply wires or terminal block.

If the heating cable fails either the insulation resistance or continuity test, stop and follow the troubleshooting instructions in Section 9.

⚠ WARNING: Fire hazard in hazardous locations. Insulation resistance tests can produce sparks. Be sure there are no flammable vapors in the area before performing this test.

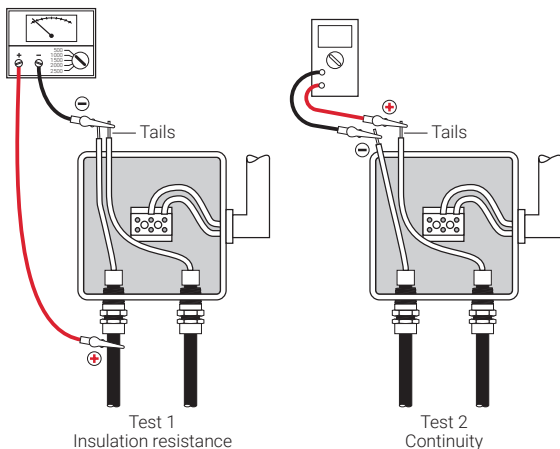

Figure 45: Insulation resistance and continuity test

8.5 Power Check

The power for single and three-phase circuits can be calculated as shown below. For clarity, automatic snow/ice melting controllers, circuit breakers, and junction boxes have been omitted.

Single Phase Circuits

Energize the circuit and measure the supply line current using a clamp-on or in-line ammeter; if an in-line ammeter is used, it must be series connected into the circuit (see Figure 46). Measure the voltage across the heating cable using a voltmeter. Record the values in the Heating Cable Installation Record in Section 11. This information is needed for future maintenance and troubleshooting.

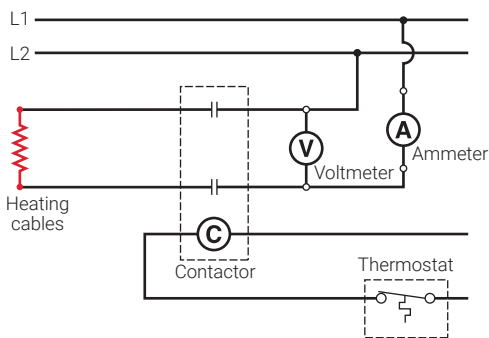

Figure 46: Using voltmeter and ammeter to measure voltage and current in a single-phase circuit

The heating cable power (watts) can be calculated by multiplying the measured voltage (volts) by the measured current (amperes) using the following formula:

$$\text{Power (W)} = \text{Volts (V)} \times \text{Current (A)}$$

Compare the calculated wattage to the wattage printed on the heating cable tag. This gives a good indication of heating cable performance. Variations of 10% to 20% are possible due to deviations in measurement equipment, supply voltage, and cable resistance.

Balanced Three Phase Circuits

Energize the circuit and measure the supply line current for each phase of the circuit using a clamp-on or in-line ammeter; if an in-line ammeter is used, it must be series connected into the circuit (see Figure 47). The three current measurements should be approximately equal. Measure the voltage across each line-to-line pair (L1-L2, L2-L3, L1-L3) using a voltmeter. The three voltage measurements should be equal. Record the values in the Heating Cable Installation Record in Section 11. This information is needed for future maintenance and troubleshooting.

Important: For a wye connected three-phase circuit, the voltage (L-N) across each heating cable will equal the line-to-line supply voltage, measured in Figure 47, divided by the square root of 3 ($V_{L-L} / \sqrt{3}$).

Delta connected circuit

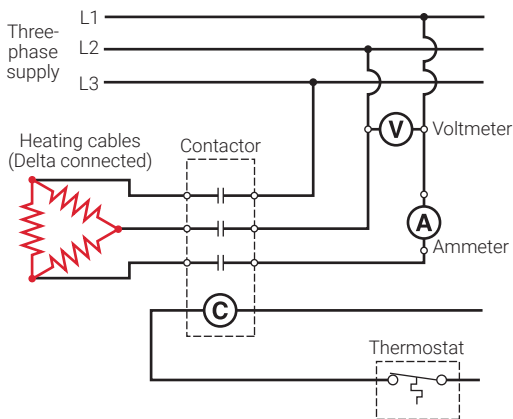

Wye connected circuit

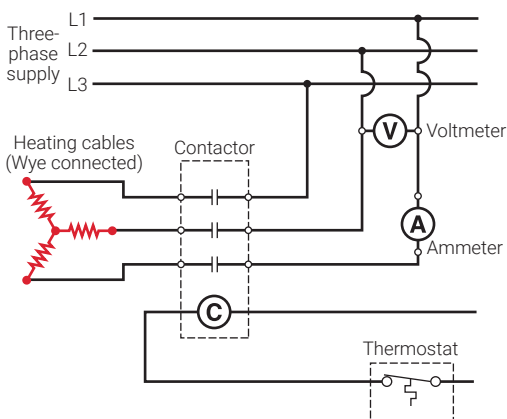

Figure 47: Using voltmeter and ammeter to measure voltage and current in each phase of a three-phase circuit

For balanced Delta and Wye connected three-phase circuits, the heating cable power (watts), for each cable, can be calculated by multiplying the measured voltage by the measured current (see Figure 47) and dividing this result by the square root of 3 using the following formula:

$$\text{Power/cable (W)} = \frac{\text{Volts (V)} \times \text{Current (A)}}{\sqrt{3}}$$

If the voltage measurement is taken directly across each heating cable in a Wye connected circuit, the power can be calculated simply by multiplying this measured voltage by the measured current using the following formula:

$$\text{Power/cable (W)} = \text{Volts (V)} \times \text{Current (A)}$$

The calculated wattage can be compared to the wattage printed on the heating cable identification tag. This gives a good indication of heating cable performance. Variations of 10% to 20% are possible due to deviations in measurement equipment, supply voltage, and cable resistance.

8.6 Fault Location Testing

MI heating cable is the most rugged heating cable available, however, damage does occur occasionally. Most damage occurs during installation due to bending too sharply, planks thrown on the cable, cutting the cable with shovels, or cutting or drilling through the cable after installation. Using good installation practices and following the “Test Procedures” in the preceding sections will reveal any installation problems and permit faults to be located and repaired prior to commissioning of the system. The distance a fault is located from the end of the cable can usually be pinpointed quite accurately; a heating cable layout drawing will be required to determine exactly where the fault lies. Refer to H58744 Tests to Locate Faults in MI Heating Cable, available on our website at chemelex.com for further information on fault location testing.

9. TROUBLESHOOTING GUIDE

Symptom	Probable Causes
Insulation resistance less than expected	<ol style="list-style-type: none">1. Rain or high humidity.2. Nicks or cuts in heating cable or cold lead sheath, with moisture present.3. Kinked or crushed heating cable or cold lead.4. Physical damage to heating cable or cold lead is causing a direct short from conductor to sheath.5. Presence of moisture in terminations or connections.6. Damaged termination.
Resistance lower than expected	<ol style="list-style-type: none">1. Conductor(s) shorted to sheath along length of heating cable.2. Both conductors in dual-conductor cable shorted together along length of heating cable.
Resistance is infinite	<ol style="list-style-type: none">1. Conductor is open circuited.
Resistance is zero	<ol style="list-style-type: none">1. Conductor(s) shorted to sheath at termination or hot/cold splice.
Circuit breaker trips	<ol style="list-style-type: none">1. Circuit breaker undersized.2. Defective circuit breaker.3. Short circuit in electrical connections.4. Excessive moisture in connection boxes.5. Nicks or cuts in heating cable or cold lead sheath, moisture present.6. Kinked or crushed heating cable or cold lead.7. GFEP device trip level too low (5 mA used instead of 30 mA) or miswired.

Corrective Action

- (1) Dry tails and face of seal. Inspect power connection box for moisture or signs or tracking. Dry out connections and retest.
- (2, 3) Fault locate to find damaged section of cable (see H58744 for details). If damaged, repair or replace heating cable or cold lead.
- (4) Check for visual indications of damage around any area where there may have been maintenance work. For embedded cables, look for cracked or damaged concrete or any evidence of work on the slab surface. Repair or replace damaged sections of heating cable, cold lead or terminations.
- (5) Dry out cold lead and/or connections and replace termination if necessary.
- (6) Replace termination.

-
- (1, 2) Fault locate to find damaged section of cable (see H58744 for details). Repair or replace damaged sections of heating cable.

-
- (1) Fault locate to find damaged section of cable (see H58744 for details). Repair or replace damaged sections of heating cable, cold lead, or terminations.

-
- (1) Fault locate to find damaged termination or hot/cold splice (see H58744 for details). Repair or replace damaged hot/cold splice or termination.

-
- (1) Recalculate circuit load current. Resize breaker and wiring as required.
 - (2) Repair or replace breaker.
 - (3) Locate and repair the incorrect connections.
 - (4) Install drains in connection boxes as required. Dry cold lead and replace terminations if required.
 - (5,6) Fault locate to find damaged section of cable (see H58744 for details). Repair or replace damaged sections of heating cable, cold lead, or terminations.
 - (7) Replace 5 mA GFEP device with 30 mA GFEP device. Check the GFEP wiring instructions.
-

Symptom	Probable Causes
Power output appears correct, but heating system not performing as expected	<ol style="list-style-type: none"> 1. Temperature controller set to incorrect temperature. 2. Thermal time delay. 3. Weather conditions too severe for design. 4. Inadequate wattage or watt density (W/sq ft; W/sq m). 5. Wrong cable installed.
Power output is zero or incorrect	<ol style="list-style-type: none"> 1. Snow/ice melting controller inoperative. 2. Temperature controller inoperative. 3. Slab/soil temperature controller wired in the normally open (N.O.) position. 4. No input voltage. 5. Broken or damaged heating cable, cold lead, or hot/cold joint. 6. Circuit breakers tripped. 7. Improper voltage used. 8. Wrong cable installed.

 **Important:** If the corrective actions above do not resolve the problem, contact your Chemelex representative for further assistance.

Corrective Action

- (1) Set temperature controller to the temperature indicated in the project specifications.
- (2) Heating cables not energized soon enough. Check system controls. Adjust or modify operation.
- (3) Snow/Ice Melting/Roof Deicing System: After snowfall ceases, manually energize system to melt remaining snow or ice (a typical Snow/Ice Melting/Roof Deicing System is not designed to effectively melt all snow/ice during the severest storms or coldest temperatures).
- (4,5) Verify installation as per design. Contact Chemelex for assistance.

-
- 1) Verify electrical connections to snow/ice melting controller and sensor, verify supply voltage to controller, verify operation, and repair or replace controller or sensor if necessary.
 - (2) Verify electrical connections to temperature controller, verify operation, and repair or replace controller if necessary.
 - (3) Confirm wiring using the normally closed (N.C.) terminals so that contacts close with falling temperature.
 - (4) Repair electrical supply lines and equipment.
 - (5) Repair or replace heating cable or cold lead.
 - (6) See above symptom under "Circuit breaker trips."
 - (7) Verify voltage and connect to proper voltage, if necessary.
 - (8) Verify installation as per design. Contact Chemelex for assistance.
-

10. CONTROLS AND ACCESSORIES

Catalog number

Ambient-Sensing Thermostats

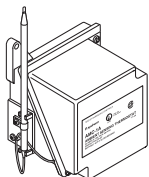

AMC-1A

AMC-1A

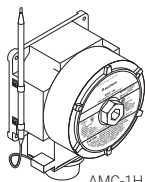

AMC-1H

AMC-1H

Line-Sensing Thermostats

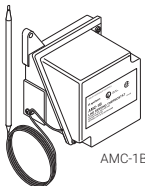

AMC-1B

AMC-1B

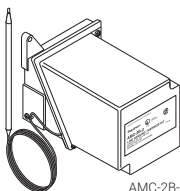

AMC-2B-2

AMC-2B-2

Description

This thermostat has an adjustable set point between 15°F and 140°F (-9°C and 60°C) and is used for freeze protection applications. The Type 4X enclosure is coated cast aluminum with stainless steel hardware. The switch is rated 480 Vac, 22 A. The stainless steel sensor assembly is permanently mounted to the enclosure. The unit is UL Listed and CSA certified for use in nonhazardous locations. Select this thermostat where set-point adjustment or mechanical ruggedness is important.

This is the hazardous location-approved version of the AMC-1A. It includes a Type 4, 7, 9 coated cast-aluminum enclosure and is approved by FM, UL Listed, and CSA certified for use in Division 1 and 2 hazardous locations. Select this thermostat when the control unit must be located in a hazardous location.

Line-sensing thermostat designed to control heat-tracing systems in nonhazardous locations. The AMC-1B senses pipe or tank wall temperatures and can be used to control a single heat-tracing circuit or as a pilot control of a contactor switching multiple heat-tracing circuits. It can also be used to indicate low-temperature or high-temperature alarm conditions.

This is the two-pole version of the AMC-1B. It has an adjustable setpoint between 25°F and 325°F (-4°C and 163°C). The control switch in this thermostat opens both heat-tracing circuit power wires. Select this thermostat when local safety standards require that both phases be switched in phase-to-phase supplies such as 208 and 240 Vac. The unit is UL Listed and CSA certified for use in nonhazardous locations. Select this thermostat where set point adjustment or mechanical ruggedness is important.

Catalog number



E507S-LS

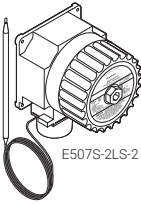

E507S-2LS-2

Electronic Thermostats and Accessories

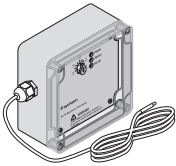

EC-TS



ECW-GF

Description

This is the hazardous location-approved version of the AMC-1B. It has an adjustable setpoint between 25°F and 325°F (-4°C and 163°C). It includes a Type 4, 7, 9 coated cast-aluminum enclosure and is approved by FM, UL Listed, and CSA certified for use in Division 1 and 2 hazardous locations. Select this thermostat when the control unit must be located in a hazardous location.

This is the two-pole version of the E507S-LS. It has an adjustable setpoint between 25°F and 325°F (-4°C and 163°C). The control switch in this thermostat opens both heat-tracing circuit power wires. Select this thermostat when local safety standards require that both phases be switched in phase-to-phase supplies such as 208 and 240 Vac. It includes a Type 4, 7, 9 coated cast-aluminum enclosure and is approved by FM, UL Listed, and CSA certified for use in Division 1 and 2 hazardous locations. Select this thermostat when the control unit must be located in a hazardous location.

Electronic thermostat housed in a Type 4X enclosure with 2 x 1/2-in conduit entries for power and one gland entry for the sensor. The temperature set point and LED indicators for alarm, power, and heating cable status can be visually checked through the clear lid. Electrical rating is 30 A at 100–277 V, 50–60 Hz, SPST switch. EC-TS includes a 25 ft (7.6 m) sensor.

Electronic controller with 30-mA ground-fault protection. The controller can be programmed to maintain temperatures up to 200°F (93°C) at voltages from 100 to 277 V and can switch current up to 30 Amperes. The ECW-GF is complete with a 25-ft (7.6-m) temperature sensor and is housed in a Type 4X rated enclosure. The controller features an AC/DC dry alarm contact relay.

Catalog number



ECW-GF-DP

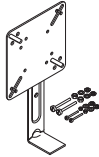

SB-110

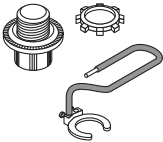

MI-GROUND-KIT

Electronic Controllers and Sensors

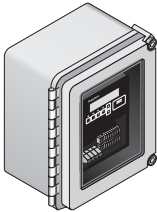

C910-485

Description

An optional remote display panel (ECW-GF-DP) can be added to provide ground-fault or alarm indication in applications where the controller is mounted in inaccessible locations.

Pipe mounting bracket for EC-TS

MI cable grounding kit (required if installing MI heating cable)

The C910-485 is a compact, full-featured microprocessor-based single-point heat-trace controller. The C910-485 provides control and monitoring of electrical heat-tracing circuits for both freeze protection and temperature maintenance, and can be set to monitor and alarm for high and low temperature, high and low current, ground-fault level, and voltage. The Raychem C910-485 controller is available with an electromechanical relay (EMR) for use in ordinary areas. The C910-485 comes with an RS-485 communication module.

Catalog number

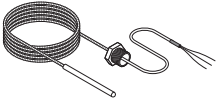

RTD-200
RTD3CS
RTD10CS
RTD50CS

Snow Melting and De-icing Controllers



APS-3C



APS-4C

Description

Stainless steel jacketed three-wire RTD (Resistance Temperature Detector) used with Raychem C910-485 controllers.

RTD-200: 3-in (76 mm) temperature sensor with a 6-ft (1.8 m) lead wire and 1/2-in NPT bushing

RTD3CS: temperature sensor with a 3-ft (0.9 m) flexible armor, 18-in (457 mm) lead wire and 1/2-in NPT bushing

RTD10CS: temperature sensor with a 10-ft (3 m) flexible armor, 18-in (457 mm) lead wire and 1/2-inch NPT bushing

RTD50CS: temperature sensor with a 50-ft (3 m) flexible armor, 18-in (457 mm) lead wire and 1/2-in NPT bushing

Automatic snow melting controller housed in a Type 3R enclosure provides effective, economical automatic control of all snow melting applications. CSA Certified, c-UL-us Listed, available in 120 V and 208-240 V, 50/60 Hz models, 24-Amp DPDT output relay, adjustable hold-on timer.

Enclosure dimensions: 11-1/2 in x 9-1/8 in x 6-9/16 in
(292 mm x 232 mm x 167 mm)

Automatic snow melting controller housed in a Type 3R enclosure provides effective, economical automatic control of all snow melting applications. The APS-4C can operate with any number of SC-40C satellite contactors for larger loads. Features include: 277 V single-phase or 208-240, 277/480, and 600 V three-phase models, built-in 3-pole contactor, integral 30 mA ground-fault circuit interrupter and an adjustable hold-on timer.

Enclosure dimensions: 11-1/2 in x 9-1/8 in x 6-9/16 in
(292 mm x 232 mm x 167 mm)

Catalog number



SC-40C

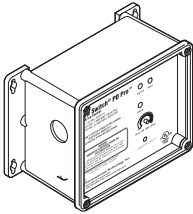

PD Pro

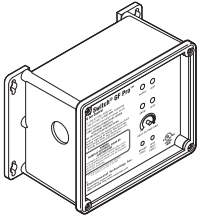

GF Pro

Snow Melting and Gutter De-Icing Sensors and Accessories

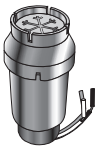

Snow Owl

Description

Satellite contactor power control peripheral for an APS-4C snow melting controller, housed in a Type 3R enclosure. Features include: 277 V single-phase or 208–240, 277/480 and 600 V three-phase models, built-in 3-pole contactor and integral 30 mA ground-fault circuit interrupter.

Enclosure dimensions: 11-1/2 in x 9-1/8 in x 6 in
(292 mm x 232 mm x 152 mm)

Automatic snow and ice melting controller for pavement, sidewalks, loading docks, roofs, gutters and downspouts in commercial and residential environments. The PD Pro interfaces with up to two sensors, (any combination of Snow Owl, GIT-1 or SIT-6E) to meet site requirements. The PD Pro is housed in an environmentally sheltered Type 4X enclosure and weighs only 3 pounds.

Automatic snow and ice melting controller for pavement, sidewalks, loading docks, roofs, gutters and downspouts in commercial and residential environments. The GF Pro interfaces with up to two sensors, (any combination of Snow Owl, GIT-1 or SIT-6E) to meet site requirements. The GF Pro is housed in an environmentally sheltered Type 4X enclosure and weighs only 3 pounds.

Features a built-in 30 mA, self-testing Ground-Fault Equipment Protection (GFEP) capability, digitally filtered to minimize false tripping. A ground-fault alarm must be manually reset using the Test/Reset switch before heater operation can continue.

Aerial snow sensor that detects precipitation or blowing snow at ambient temperatures below 38°F (3.3°C). For use with either an APS-3C or APS-4C automatic snow melting controller.

Catalog number



SIT-6E



GIT-1

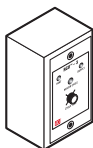

RCU-3

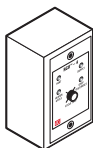

RCU-4

Description

Pavement-mounted sensor signals for the heating cable to turn on when the pavement temperature falls below 38°F (3.3°C) and precipitation in any form is present. Microcontroller technology effectively eliminates ice bridging while ensuring accurate temperature measurement. For use with either an APS-3C or APS-4C automatic snow melting controller.

Gutter sensor that detects moisture at ambient temperatures below 38°F (3.3°C). For use with an APS-3C or APS-4C automatic snow controller, or a SC-40C satellite contactor.

The RCU-3 provides control and status display to the APS-3C controller from a remote location. It has a 2, 4, 6 or 8 hour CYCLE TIME adjustment, independent of APS-3C setting.

The RCU-4 provides control and status display to the APS-4C controller and SC-40C Satellite Contactor from a remote location. It has a 2, 4, 6 or 8 hour CYCLE TIME adjustment, independent of the APS-4C or SC-40C setting.

Junction Boxes

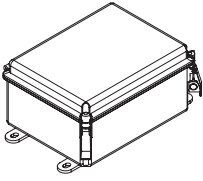

MIJB-864-A

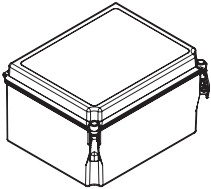

MIJB-1086-B

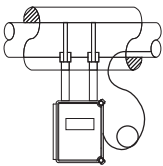

MBRP-B

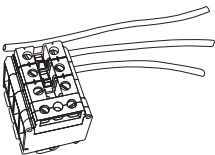

MIJB-LPWR-KIT

Description

Junction box with pre-drilled earth plate for use with MI heating units. Typical uses - Power, splice and end box for three-phase systems. Hazardous locations: CID2 Groups B, C and D. Maximum operating voltage 600Vac. Maximum 35A per terminal, rated 18AWG to 6AWG, Type 4X.

Entries: Up to 8 x ½" and 3 x ¾". Power cable gland and hubs not included. Two mounting brackets (MBRP-B) and two pipe straps must be ordered separately for installation.

Enclosure dimensions: 8" x 6" x 4" (200 x 150 x 100 mm).

Junction box with pre-drilled earth plate for use with MI heating units. Accommodates up to 7 outgoing heating cables and one incoming power cable. It can also be used as a marshalling box – one incoming power cable and 5 outgoing power cables. Typical uses - Power or marshalling, splice and end box for three-phase systems.

Hazardous locations: CID2 Groups B, C and D. Maximum operating voltage 600Vac. Maximum 35A per terminal, rated 18AWG to 6AWG, Type 4X.

Entries: Up to 11 x ½" and 8 x ¾". Power cable gland and hubs not included. Two mounting brackets (MBRP-B) and two pipe straps must be ordered separately for installation. Order a separate MIJB-LPWR-KIT for #2 or #4AWG power cable to downsize to #6AWG (35A).

Enclosure dimensions: 10" x 8" x 6" (250 x 200 x 150 mm).

Enclosure mounting bracket for MIJB series fiberglass enclosures.

Mounting bracket enables enclosure installation and connection prior to application of insulation and cladding. Stainless steel pipe support bracket for MIJB-864-A, MIJB-1086-A and MIJB-1086-B fiberglass enclosures. Two brackets are required to support each enclosure. Each bracket requires one pipe strap.

Terminal kit to facilitate downsizing of large power cables.

Large power wire kit to downsize #2 or #4 power cable to #6AWG (max 35amps for enclosure terminal blocks). Use with MIJB-1086-A and MIJB-1086-B enclosures as required.

Catalog number

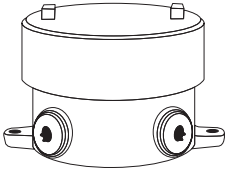

XMI-JB

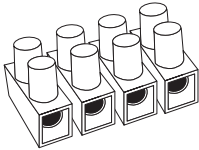

4POLETSTRIP

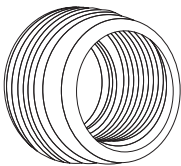

PTRDBH3412

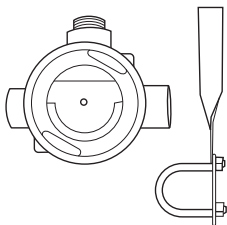

PT-JB

Description

Aluminum enclosure for CID1 areas. Typical uses: MI heating units power or splice connection box, RTD connection box
Hazardous locations - CID1 Groups B, C and D, Maximum operating voltage 600Vac, Includes 4 pole terminal block (CSA-600 Vac, 65 A, 18-6 AWG /UL-300 Vac, 65 A, 18-6 AWG), Type 4X.
Entries : 5 x 3/4" and includes 3 x 3/4" plugs, two reducer bushings (3/4" x 1/2") and two mounting feet with space to tap hole for bonding wire. Power cable gland should be purchased separately. Additional terminal strips or reducer bushings may also be purchased separately for additional RTD connection. (4POLETSTRIP and PTRDBH3412)
Enclosure dimensions: 4 1/2" x 3 1/2" (114 x 89 mm).

Terminal strip for enclosure. 4 pole terminal strip (CSA-600 Vac, 65 A, 18-6 AWG /UL-300 Vac, 65 A, 18-6 AWG) for use with XMI-JB enclosure. May be used for additional RTD connections.

Reducer bushing for enclosure.

Zinc plated steel reducer bushing for use with XMI-JB enclosure. Reduces 3/4" NPT tapered hole to 1/2" NPT. Body length 23/32" (18 mm), Class I, Div. 1 & 2, Groups A, B, C, D. Class I, Zone 1, Groups IIC, IIB, IIA. Class II, Div. 1 & 2, Groups E, F, G.

A smaller ferro-alloy junction box with three entries for use with MI heating cables.
Typical use : power or splice connection box
Three 3/4" NPT entries. Provided with one plug and two 3/4" x 1/2" reducers. Includes 4 pole terminal block (CSA-600 Vac, 65 A, 18-6 AWG / UL-300 Vac, 65 A, 18-6 AWG) and stainless steel support bracket (U-clamp). UL and CSA approved for: Class I, Div. 1 & 2, Groups A, B, C, D; Class II, Div. 1 & 2, Groups E, F, G.
Enclosure dimensions: 5.5" x 4.75" x 3" (140 mm x 121 mm x 76 mm).

Power Distribution and Control Panels

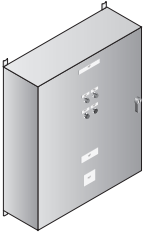

SMPG1

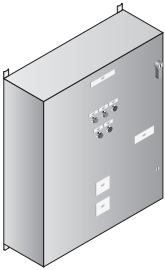

SMPG3

Accessories

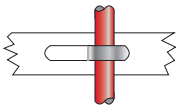

HARD-SPACER GALV-25MM-25M

HARD-SPACER SS-25MM-25M



SMCS

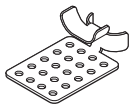

GMK-RC

Description

Single-phase power distribution panel that includes ground-fault protection, monitoring, and control for snow melting systems. Single-phase voltages include 208 and 277 V. Refer to the SMPG1 data sheet (H57680) for information on selecting a control panel.

If standard configurations do not meet your requirements, contact your Chemelex representative for a quotation on a custom SMPG1 panel.

Three-phase power distribution panel that includes ground-fault protection, monitoring, and control for snow melting systems. Three-phase voltages include 208, 480, and 600 V. Refer to the SMPG3 data sheet (H57814) for information on selecting a control panel.

If standard configurations do not meet your requirements, contact your Chemelex representative for a quotation on a custom SMPG3 panel.

Galvanized steel prepunched strapping. Use when cable is embedded in concrete or mortar. 82 ft (25 m) rolls.

Stainless steel prepunched strapping. 82 ft (25 m) rolls.

Snow melt caution sign
Dimensions 6 x 4 in (150 x 100 mm)

Roof clips - 1 box per 25' of roof edge when zig-zag layout is used. 50 pieces/box.

Catalog number

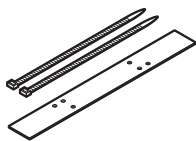

GMK-RAKE

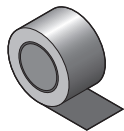

AT-180

Description

Hanger bracket – one hanger per cable in downspout or as required for mechanical protection. 1 piece/package.

Aluminum tape. 180 ft (55 m) roll

11. INSTALLATION AND INSPECTION RECORDS

Heating Cable Installation Record

INSTALLATION LOCATION

Project name: _____

Reference drawing: _____

Company: _____

Address _____

State/Province: _____

Installation environment: Commercial Industrial Hazardous Area

If installed in a hazardous area, fill in the following additional information:

Area: Ignition temperature _____ °F °C

Group classification _____

Heating cable temp code/ sheath temp. (from tag) _____

INSTALLED BY

Company: _____

Address _____

State/Province: _____

Name _____

VISUAL INSPECTION (check for all heating cables and cold leads)

Cold Lead:

Embedded applications: Hot/cold joints are embedded in soil/slab at least 6 in (15 cm) in from edge of heated area? Yes

The cold lead is protected where it emerges from the heated area? Yes

Hot/cold joints are spaced at least 6" apart? Yes

All junction boxes are mounted above grade, and installed so that water cannot enter them? Yes

The cable sheath is securely connected to ground? Yes
NPT threaded connectors must be properly grounded.

Installation date _____

Area size _____ sq ft sq m

City _____

Postal code _____

City _____

Postal Code _____

Phone _____

Heating Cable:

Cable spacing is as specified for the design? Yes

Enter spacing: ____ in (cm)

Heating cable is fastened to pre-punched strapping, set at 3 - 4 ft (0.9 - 1.2 m) spacing? (2-pour concrete) Yes

Location of all concrete crack control / expansion joints identified before pouring? Yes

Heating cable does not cross expansion joints? Yes

Steel angle iron and RTV compound is used to cross concrete crack control joints? Yes

Heating cable jacket is not damaged? Yes

Inside radius of bends in the heating cable are not less than 6 times the cable diameter? Yes

Heating cables are not grouped, touching or crossed? Yes

Heating cables not spaced closer than 3 in (75 mm) apart? Yes

Heating cables are not in contact with insulating material? Yes

Heating cables are installed in accordance with manufacturer's recommendations for the specific installation? Yes

ELECTRICAL TESTING

Note: Minimum acceptable insulation resistance shall be 20 MΩ (100 MΩ upon receipt)
 Perform Megger – I.R. tests at 1000Vdc (bypass controller if applicable)
 Megohmmeter manufacturer/model _____
 Multimeter manufacturer/model _____

1 Receipt of Material

	Heating Cable Catalog No. /Tag No.	Insulation Resistance (MΩ)	Continuity (Ω)
Cable #1	_____	_____	_____
Cable #2	_____	_____	_____
Cable #3	_____	_____	_____
Cable #4	_____	_____	_____
Cable #5	_____	_____	_____
Cable #6	_____	_____	_____
Cable #7	_____	_____	_____
Cable #8	_____	_____	_____
Cable #9	_____	_____	_____
Cable #10	_____	_____	_____
Cable #11	_____	_____	_____
Cable #12	_____	_____	_____

3 Initial Start-up (Commissioning)

 **WARNING:** Disconnect all power before performing insulation resistance and continuity tests.

	Heating Cable Catalog No. /Tag No.	Heating Cable Location	Breaker Number
Cable #1	_____	_____	_____
Cable #2	_____	_____	_____
Cable #3	_____	_____	_____
Cables 1,2,3 three phase connected	Yes <input type="checkbox"/> No <input type="checkbox"/>	Delta <input type="checkbox"/>	Wye <input type="checkbox"/>
Cable #4	_____	_____	_____
Cable #5	_____	_____	_____
Cable #6	_____	_____	_____
Cables 4,5,6 three phase connected	Yes <input type="checkbox"/> No <input type="checkbox"/>	Delta <input type="checkbox"/>	Wye <input type="checkbox"/>
Cable #7	_____	_____	_____
Cable #8	_____	_____	_____
Cable #9	_____	_____	_____
Cables 7,8,9 three phase connected	Yes <input type="checkbox"/> No <input type="checkbox"/>	Delta <input type="checkbox"/>	Wye <input type="checkbox"/>
Cable #10	_____	_____	_____
Cable #11	_____	_____	_____
Cable #12	_____	_____	_____
Cables 10,11,12 three phase connected	Yes <input type="checkbox"/> No <input type="checkbox"/>	Delta <input type="checkbox"/>	Wye <input type="checkbox"/>
Ground-fault protection (type)	_____		
Test ground fault	_____		
Test automatic snow/ice melting controller	_____		
Test temperature controller	_____		
Contractor's signature:	_____		
Accepted by:	_____		
Date:	_____		

Maintenance Log Record

Area location: _____

CIRCUIT INFORMATION

Breaker panel number: _____

VISUAL

Heating system components

Enclosures, junction boxes, contactors sealed _____

Presence of moisture _____

Signs of corrosion _____

Damage to cold lead or termination _____

ELECTRICAL TESTING

Conduct insulation resistance test at 1000 Vdc (bypass controller is applicable)

 **WARNING: Disconnect all power before performing insulation resistance and continuity tests.**

Heating Cable Catalog No. /Tag No.	Heating Cable Location	Breaker Number
Cable #1 _____	_____	_____
Cable #2 _____	_____	_____
Cable #3 _____	_____	_____
Cables 1,2,3 three phase connected Yes <input type="checkbox"/> No <input type="checkbox"/>	Delta <input type="checkbox"/>	Wye <input type="checkbox"/>
Cable #4 _____	_____	_____
Cable #5 _____	_____	_____
Cable #6 _____	_____	_____
Cables 4,5,6 three phase connected Yes <input type="checkbox"/> No <input type="checkbox"/>	Delta <input type="checkbox"/>	Wye <input type="checkbox"/>
Cable #7 _____	_____	_____
Cable #8 _____	_____	_____
Cable #9 _____	_____	_____
Cables 7,8,9 three phase connected Yes <input type="checkbox"/> No <input type="checkbox"/>	Delta <input type="checkbox"/>	Wye <input type="checkbox"/>
Cable #10 _____	_____	_____
Cable #11 _____	_____	_____
Cable #12 _____	_____	_____
Cables 10,11,12 three phase connected Yes <input type="checkbox"/> No <input type="checkbox"/>	Delta <input type="checkbox"/>	Wye <input type="checkbox"/>
Ground-fault protection (type) _____		
Test ground fault _____		
Test automatic snow melting controller _____		
Test temperature controller _____		

Comments and actions _____

Prepared by: _____

Approved by: _____

North America

Tel +1 800 545 6258

info@chemelex.com

chemelex
excellence is everything

chemelex.com

Raychem Tracer Pyrotenax Nuheat

©2025 Chemelex. All Chemelex marks and logos are owned or licensed by Chemelex Europe GmbH or its affiliates. All other trademarks are the property of their respective owners. Chemelex reserves the right to change specifications without notice.

RAYCHEM-IM-H60759-MIMiscApplication-EN-2504

PCN 481825-000