

Raychem

Touch 1500-EX

User Interface Terminal for Raychem NGC Systems
Installation Instructions

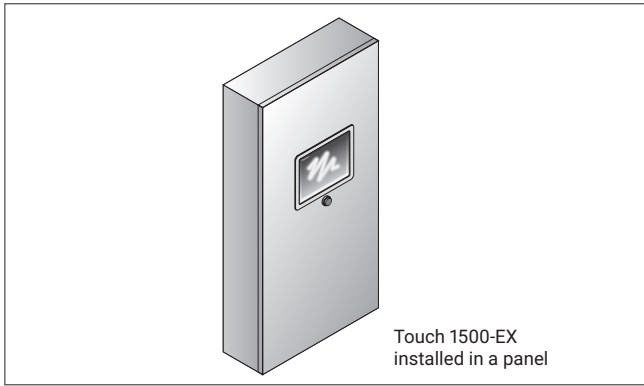

DESCRIPTION

The Raychem Touch 1500-EX is a panel mounted display used in conjunction with other Raychem control and monitoring devices. The Touch 1500-EX is rated IP 65 (Type 4X), and can be mounted indoors or outdoors. The Touch 1500-EX kit includes all hardware required for mounting in a suitable electrical panel. Additional materials are required for electrical connections and are detailed below. These instructions describe how to mount the Touch 1500-EX in an electrical panel and are intended only for qualified personnel experienced in panel construction.

KIT CONTENTS

Qty	Description
1	Touch 1500-EX
16	6/32 in Kep nuts (locking nuts)

TOOLS REQUIRED

- Masking tape
- #16 5 mm (3/16 in) drill bit
- Metal file
- In-line torque wrench with 8 mm (5/16 in) socket

ADDITIONAL MATERIALS (TO BE ORDERED SEPARATELY)

Qty	Description	Manufacturer	Manufacturer Part Number
3	Alarm relays – 12 VDC, 12 A, SPDT	TE Connectivity	RTB14012F
3	Alarm relay sockets	TE Connectivity	RT78724
1	Push to test alarm light 120 or 230 Vac		

Note: Equivalent parts may be used.

CERTIFICATIONS / APPROVALS

- TYPE 4X, IP65 protection on front panel
- FCC Part15 Subpart B/ICES 003 Class A
- CE marking
 - Low Voltage Directive (2014/35/EU) EN 62368-1:2014 / A11:2017
 - EMC Directive (2014/30/EU) EN 55032:2015 EN 55035:2017
- Conforms to UL 62368-1, 2nd Ed, 2014-12-01; CAN/CSA C22.2 No. 62368-1-14, 2nd Ed, Issued: 2014-12-01; UL 60950-1, 2nd Edition, 2019-05-09 ; CAN/CSA C22.2 No. 60950-1-07, 2nd Edition, 2014-10
- ATEX Directive (2014/34/EU)
 - EN 60079-0:2017
 - EN 60079-11:2012
 - EN 60079-7: 2015 +A1:2018
- IECEX
 - IEC 60079-0 2017
 - IEC 60079-11 2012
 - IEC 60079-7, 5.1 Ed



II 3 G Ex ic ec IIC T4 Gc



General

Area of Use	Ordinary (nonhazardous) and Class I Div. 2 / Zone 2 hazardous locations, indoors or outdoors (IP65, Type 4X)
Supply Voltage	12 -27VDC, 4A-1.5A respectively, 40W max / 25W nominal, AWG 16-20 (1.5 mm ² - 0.5 mm ²)
Operating Temperature	-40°F to 140°F (-40°C to 60°C)
Min. Storage Temperature	-40°F to 176°F (-40°C to 80°C)
Dimensions	16.61 in W x 13.31 in H x 2.68 in D (422 mm W x 338 mm H x 68 mm D)
Humidity Range	10 to 90% Non-Condensing
Wire rating	85°C or higher
Recommended Screw Torque	5.5 in lbs (0.62Nm)

Alarm Outputs

Transistor open collector outputs	5 – 30 Vdc with a max. sink current of 500 mA, AWG 16-20 (1.31 mm ² - 0.52 mm ²)
Use to drive external relays	Relays may be assigned for alarm outputs.

LCD Display

Display	LCD is a 15 in color XGA with integral LED backlight.
Touch Screen	5-wire resistive touch screen interface for user entry; compatible with glove use
Operating Temperature	-40°F to 140°F (-40°C to 60°C). Enclosure heater recommended below 32°F (0°C)

Network Connection

Local/ Remote Port	Raychem RS-232/RS-485 ports may be used to communicate with host computers or DCS
Local RS-232	A non-isolated, 9 pin D sub male
Maximum cable length	RS-232 Cable Length not to exceed 10' (3m)
Remote RS-485	Used to communicate to upstream devices such as a PLC or DCS 2-wire isolated shielded twisted pair.
Data Rate	9600 to 57600 baud.
Maximum cable length	RS-485 Cable Length not to exceed 1200 m (4000 ft) at 9600 baud.
Field RS-485	Used to communicate with external devices, such as Raychem NGC-40 Bridge Module, Elexant 4010i, Elexant 4020i, Elexant 3500i, RMM2 and RMM3.
Field RS-485	2-wire isolated shielded twisted pair
Data Rate	Fixed at 9600 baud
Maximum cable length	RS-485 Cable Length not to exceed 1200 m (4000 ft) at 9600 baud.
LAN	10/100 Base-T Ethernet port with Link and Activity Status LEDs on Port 1, 2 – Inactive and Port 3 – Active.
USB Ports	USB 2.0 Host port Type A receptacle on Ports 1 and 2. Ports 3 and 4 inactive.

⚠ WARNING:

Do not connect/disconnect equipment unless power has been switched off or the area is known to be non-hazardous. Ne débranchez pas l'équipement tant que l'alimentation est coupée ou que la zone est connue pour être non dangereuse.

⚠ IMPORTANT:

- Use appropriately classified and listed Power Supply (Limited Power Source, or LPS). Follow all applicable wiring codes and regulations.
- Peripheral equipment must be suitable for the location in which it is used.
- There are no non-incendive circuits or non-incendive field wiring within or associated with the unit.
- Only technically qualified service personnel are permitted to install or service the equipment.
- Do not disassemble the system - no user-serviceable parts inside.
- Do not operate the equipment if it has been damaged.
- Utilisez une source d'alimentation correctement classée et répertoriée (source d'énergie limitée ou LPS). Suivez tous les codes et normes de câblage applicables.
- L'équipement périphérique doit être adapté à l'emplacement dans lequel il est utilisé.
- Il n'y a pas de circuits non incendiaires ni de câbles de terrain non incendiaires à l'intérieur ou associés avec l'équipement.
- Seul le personnel qualifié est autorisé à installer ou à entretenir l'équipement.
- Ne pas démonter le système - aucune pièce interne ne peut être réparée par l'utilisateur.
- N'utilisez pas l'équipement s'il a été endommagé.

PROVIDE SUITABLE PANEL ENCLOSURE, AND DETERMINE LOCATIONS FOR TOUCH 1500-EX ASSEMBLY IN PANEL

1. Provide suitable panel enclosure

To protect its electronic components, the Chemelex Touch 1500-EX must be mounted in a panel with a minimum IP32 (Type 1) enclosure for non-hazardous indoor locations. An IP52 (Type 12) or better enclosure is recommended. An IP54 (Type 4) or better enclosure is required for hazardous locations. The Touch 1500-EX assembly comes with a sealing gasket and hardware to mount the enclosure.

Note: The Touch 1500-EX is designed for operation in ambient temperatures from -40°F to 140°F (-40°C to 60°C). If the ambient temperature is outside this range, a space heater and/or cooling fan will be required in the panel.

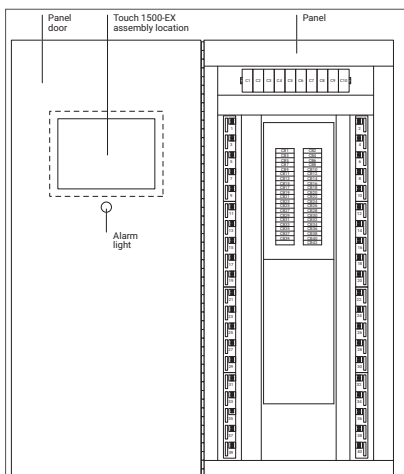

2. Determine locations for the Touch 1500-EX assembly in the electrical panel

The Touch 1500-EX should be located on the front of the panel near eye level (for convenient viewing). The Touch 1500-EX assembly is an electronic unit and must not be located where it will be exposed to strong magnetic fields or excessive vibration.

Conditions of Safe Use in Hazardous (Explosive) Atmospheres

The equipment must be installed in a low risk mechanical danger environment. The equipment shall only be used in an area of at least pollution degree 2, as defined in IEC/EN 60664-1.

- The equipment shall be installed in a back enclosure with tool removable door or cover that provides a degree of protection not less than IP54 in accordance with IEC/EN 60079-0 rated for
- Internal and external ambient of: -40°F to 140°F (-40°C to 60°C)
 - ATEX / IECEx: Zone 2 or better
 - US / CAN: Class I Div 2 or better

Provisions shall be made external to the equipment to provide transient protection at a level not exceeding 140% at the power supply terminals

Conditions d'utilisation en toute sécurité dans des atmosphères dangereuses (explosives)

Cet équipement doit être installé dans un environnement à faible risque de dommages mécaniques. Cet équipement doit être installé dans une armoire ou un panneau classé pour les zones dangereuse comme suit:

- Ambiance interne et externe de: -40°C à + 60°C
- Indice de protection minimum IP54
- ATEX / IECEx: Zone 2 ou supérieur
- US / CAN: Class I Div 2 ou supérieur
- Ne peut être ouvert qu'à l'aide d'un outil

CUT OPENING AND MOUNT TOUCH 1500-EX ON FRONT OF PANEL

1. Locate the Touch 1500-EX on front of panel

Locate the Touch 1500-EX assembly on the front of the panel at a level convenient for viewing. Make sure the cover on the back of the assembly will not interfere with existing panel hardware.

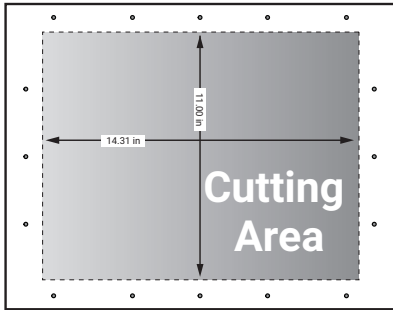

Note: Cutting the opening for the display is a craft sensitive procedure; if it is not done correctly, the panel door can be damaged. The procedure for laying out and cutting the opening for the display must be undertaken with care, and by personnel qualified and experienced in panel construction.

2. Prepare and mark the position of the display opening and mounting holes

- Use the cut-out directions to lay out the opening for the Touch 1500-EX display.
- Apply two layers of masking tape around the outer perimeter of the intended opening to prevent scratching the panel surface with the jigsaw.

3. Cut the display opening

Cut the opening for the Touch 1500-EX with a jigsaw using a 24 TPI blade. Take care not to damage the panel door. Remove all rough edges and burrs with a metal file before proceeding.

4. Drill the mounting holes

Drill the 16 holes with a 3/16" (5 mm) drill bit to mount the Touch 1500-EX assembly in the panel.

Note: The following steps are most easily accomplished if the panel door is on a horizontal surface.

5. Mount the user interface assembly onto the panel door

- Place the Touch 1500-EX assembly in position; the sixteen studs go through the sixteen holes on the Touch 1500-EX assembly mounting plate (see figure below).

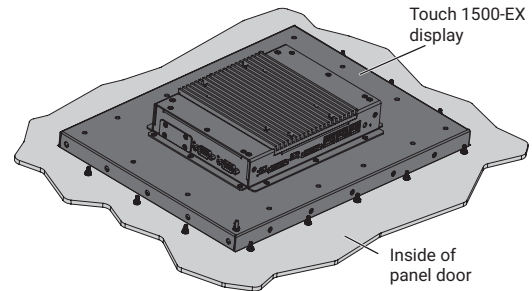
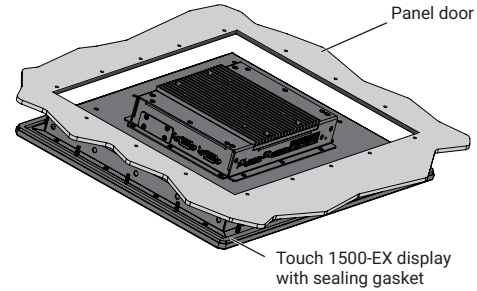

- Place the supplied 6/32 in Kep nuts on each of the sixteen mounting studs. Fasten only hand tight.

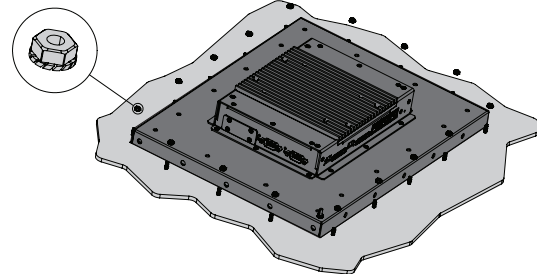

- Look at the front of the panel, and align the Touch 1500-EX assembly so it is level (loosen nuts if necessary to reposition the Touch 1500-EX assembly).
- After the display is properly positioned, tighten the nuts to 0.62 Nm (5.5 in/lb) of torque using a 5/16" (8 mm) in-line torque wrench. **Do not overtighten and risk damage to hardware.**
- **Tighten Kep nuts in the sequence shown for proper sealing.**

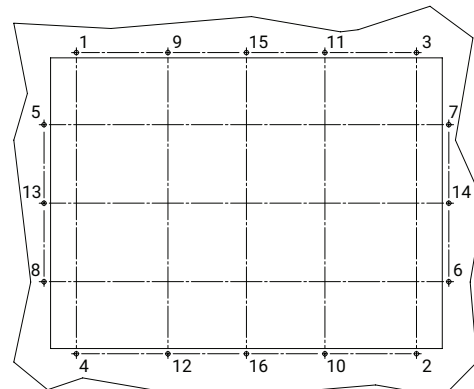

TOUCH 1500-EX CUT OUT DIMENSIONS IN (MM)

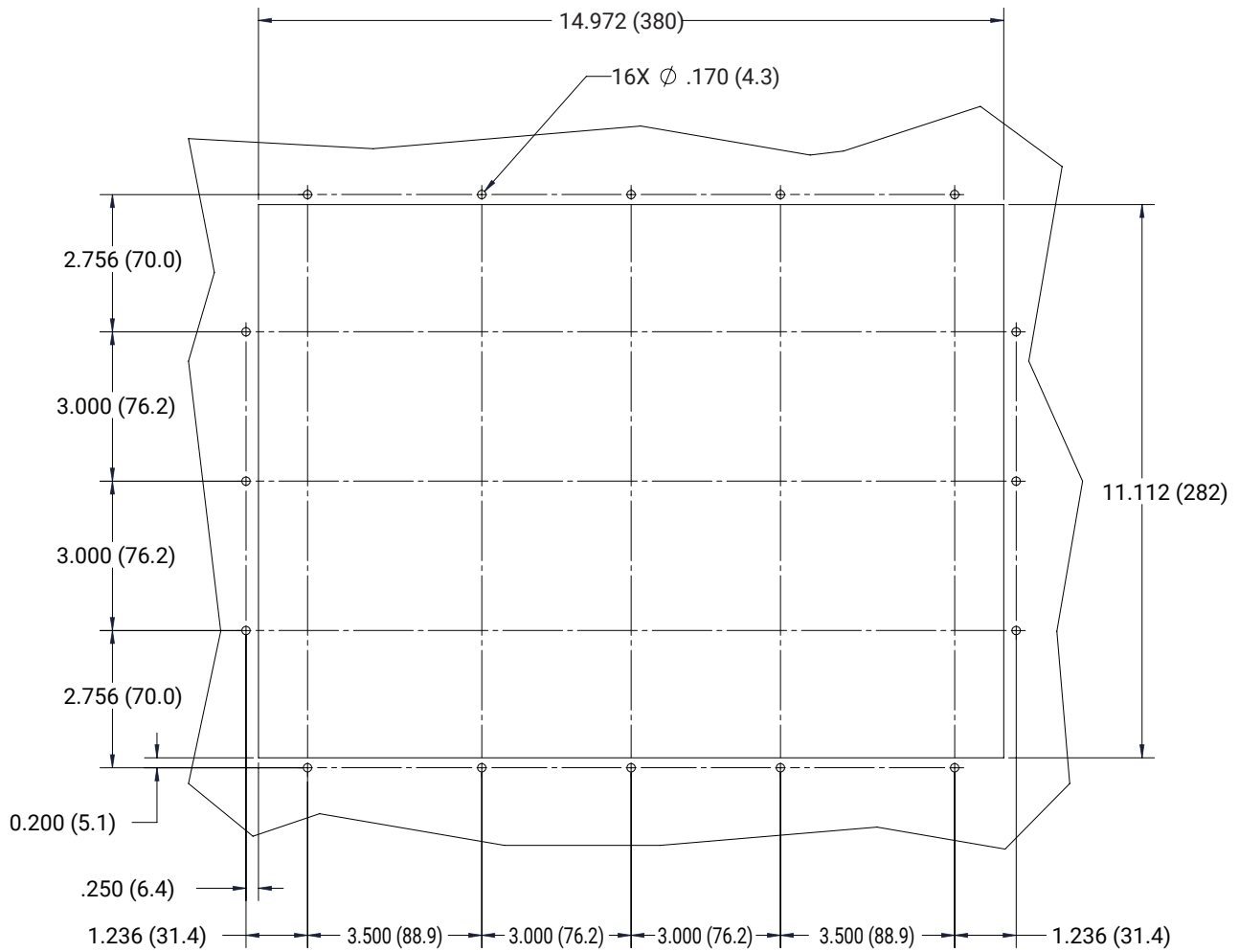

TOUCH 1500-EX CONNECTION DIAGRAM

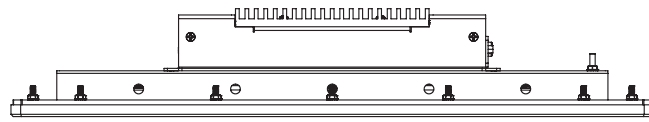

Top View

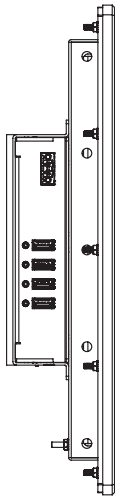

Side View

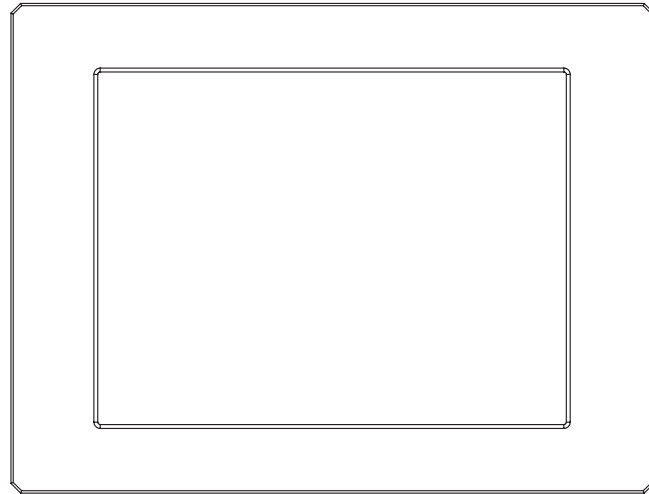

Front View

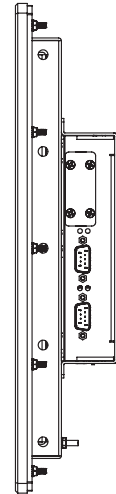

Side View

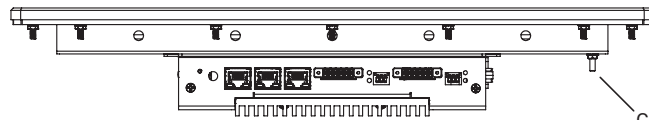

Bottom View

Grounding Terminal

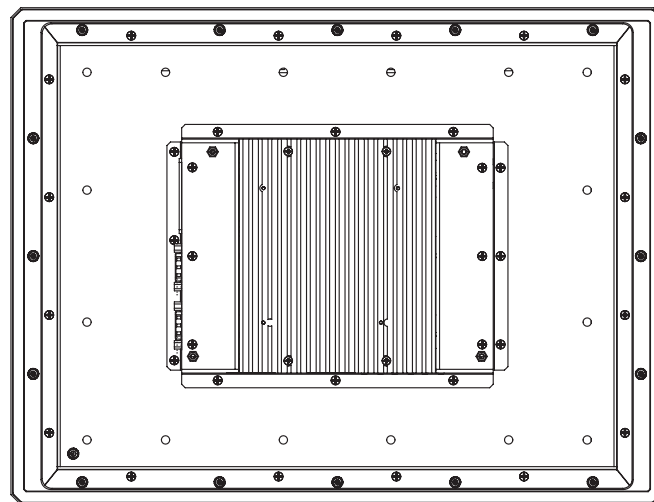

Back view

CONNECT POWER

Connect 24 Vdc to the male power connection fitting located on the left side of the Touch 1500-EX. Make sure to connect the grounding terminal. Ensure the cables are routed through the cable clamp as shown.

Note: The Touch 1500-EX is rated for 12 -27 Vdc. Since the NGC-40 modules are rated for 24 Vdc, we have used this voltage to also power the Touch 1500-EX. As a result, the recommend alarm relays and lights detailed in the “Additional Materials” are rated for 24 Vdc.

Provision shall be made external to the equipment to provide transient protection at a level not exceeding 140% at the power supply terminals.

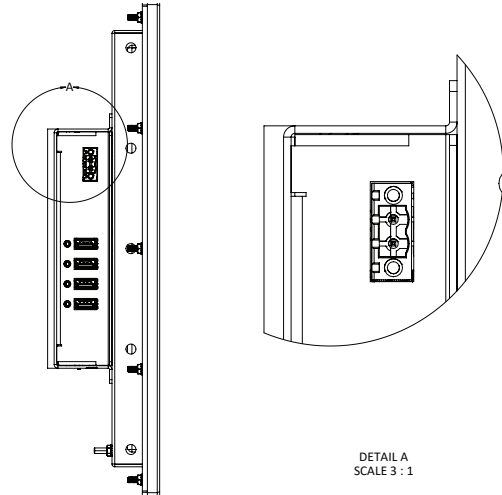

INSTALL COMMON ALARM LIGHT AND ALARM RELAYS

Mount the alarm relay on a DIN rail inside the panel enclosure.
Mount the Alarm light on the panel's door below the touch screen.

Per the below drawing, bring 24 Vdc to the Relay Driver Output at the bottom of the touch screen, to the alarm relay and alarm light.

Per the below drawing, wire between the Open Relay Driver Output, alarm relay, and alarm light.

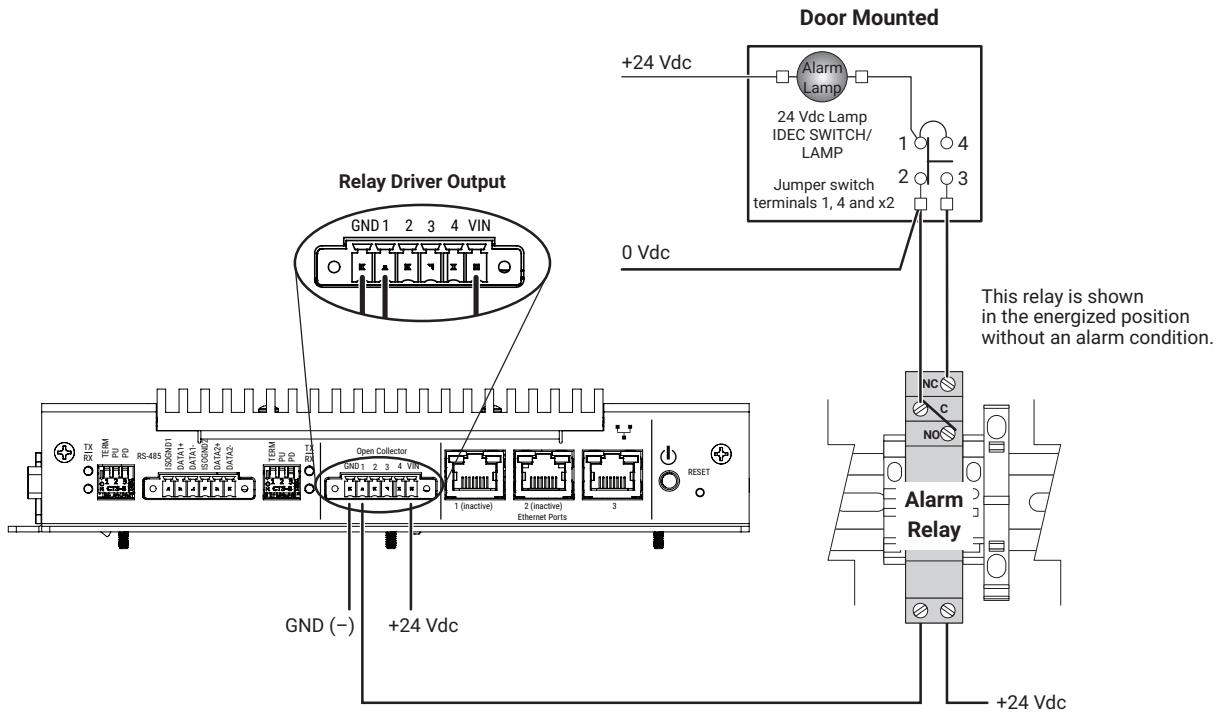

COMMUNICATION

The Touch 1500-EX has two isolated RS-485 ports located at the bottom.

Field Side Port (DATA 1 +/-)

The RS-485 port labeled "DATA1+ and DATA1-" is the field side port that is used to communicate with ModBus devices (ie. NGC-40 Bridge Module, Elexant 4010i, Elexant 4020i, Elexant 3500i, RMM2 and RMM3).

Remote Port (DATA 2 +/-) – Optional

The RS-485 port labeled "DATA2+ and DATA2-" is the Host side port that is used to communicate with to a host computer or to a DCS.

Local Host Port (RS-232) – Optional

The RS-232 port labeled "RS-232 1" is the RS-232 port that can be used as local Host port that is used to communicate with to a host computer. If the RS-232 port is utilized, the supplied female to female, 9-pin null modem adaptor cable must be used.

Ethernet Port – Optional

The Ethernet Port labeled "Ethernet Port 3" is the Host side port that can be used to communicate to a host computer (using Raychem Supervisory Software) or to a DCS. Ethernet Ports 1 & 2 are inactive and cannot be used.

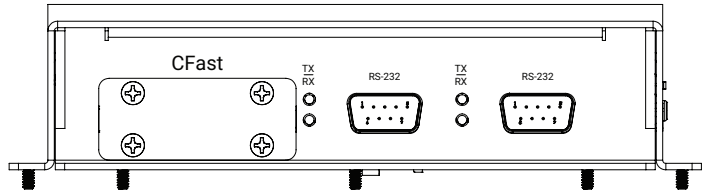
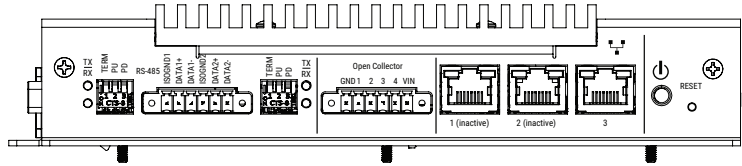

RS-485 CONFIGURATION SWITCHES

The configuration switches are found on the bottom side of the Touch 1500-EX. Refer to the table below for settings.

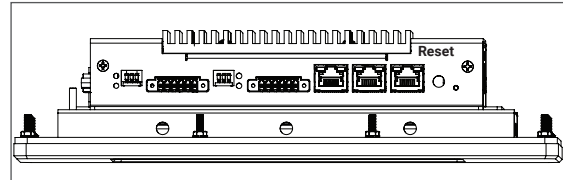

Switch	Position		Comments
	On	Off	
Pull-down (PD)	(As-shipped default) RS-485 network "-" signal is forced to a determinate state when idle.	RS-485 network "-" signal is not forced to a determinate state when idle.	One device (typically this Touch 1500-EX) on the RS-485 network should force the network "-" signal to a determinate state.
Pull-up (PU)	(As-shipped default) RS-485 network "+" signal is forced to a determinate state when idle.	RS-485 network "+" signal is not forced to a determinate state when idle.	One device (typically this Touch 1500-EX) on the RS-485 network should force the network "+" signal to a determinate state.
Termination (TERM)	(As-shipped default) RS-485 network is terminated with 120-ohm resistor.	RS-485 network is not terminated.	Terminate the device (Touch 1500-EX or other) that is at each end of the RS-485 network, for a total of two terminated devices. No other devices on the network should be terminated.

RESET SWITCH

The Reset switch can be found on the bottom of the Touch 1500-EX. A pointed object is required to press the reset switch and restart the Touch 1500 software.

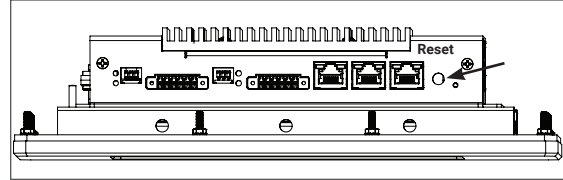

SERVICING

The Touch 1500-EX contains no user-serviceable parts. Contact your Chemelex representative for service and a return authorization number if required.

CLEANING

The touch screen area of the Touch 1500-EX may be cleaned with a damp cloth. Typical window cleaning agents may be applied to aid in the removal of dirt, dust and grease. **Do not use abrasive cleaners.**





PRODUCT LABEL

Part No.: R9075-15
Serial No.:

Raychem

TOUCH 1500-Ex

Power Rating: 12–27 VDC \approx 4A - 1.5A
UL 21 ATEX 2493X IECEx UL 21.0039X
Ⓜ II 3 G Ex ic ec IIC T4 Gc
Class I Div. 2 Groups A, B, C, D, T4
–40°C ≤ Ta ≤ 60°C

   
I.T.E for Haz. Loc.
E516513

⚠ WARNING: Explosion Hazard - Do not disconnect equipment unless power has been switched off or the area is known to be non-hazardous. No serviceable parts inside.
⚠ AVERTISSEMENT : Risque d'explosion - Ne débranchez pas l'équipement que l'alimentation est coupée ou que la zone est connue pour être non dangereuse. Aucune pièce interne réparable par l'utilisateur.
Tested to comply with FCC Class A standards. CAN ICES3(A)/NMB3(A).

©2025 Chemelex, 899 Broadway, Redwood City, CA 94063 chemelex.com
Made in USA H61097-EN 2504

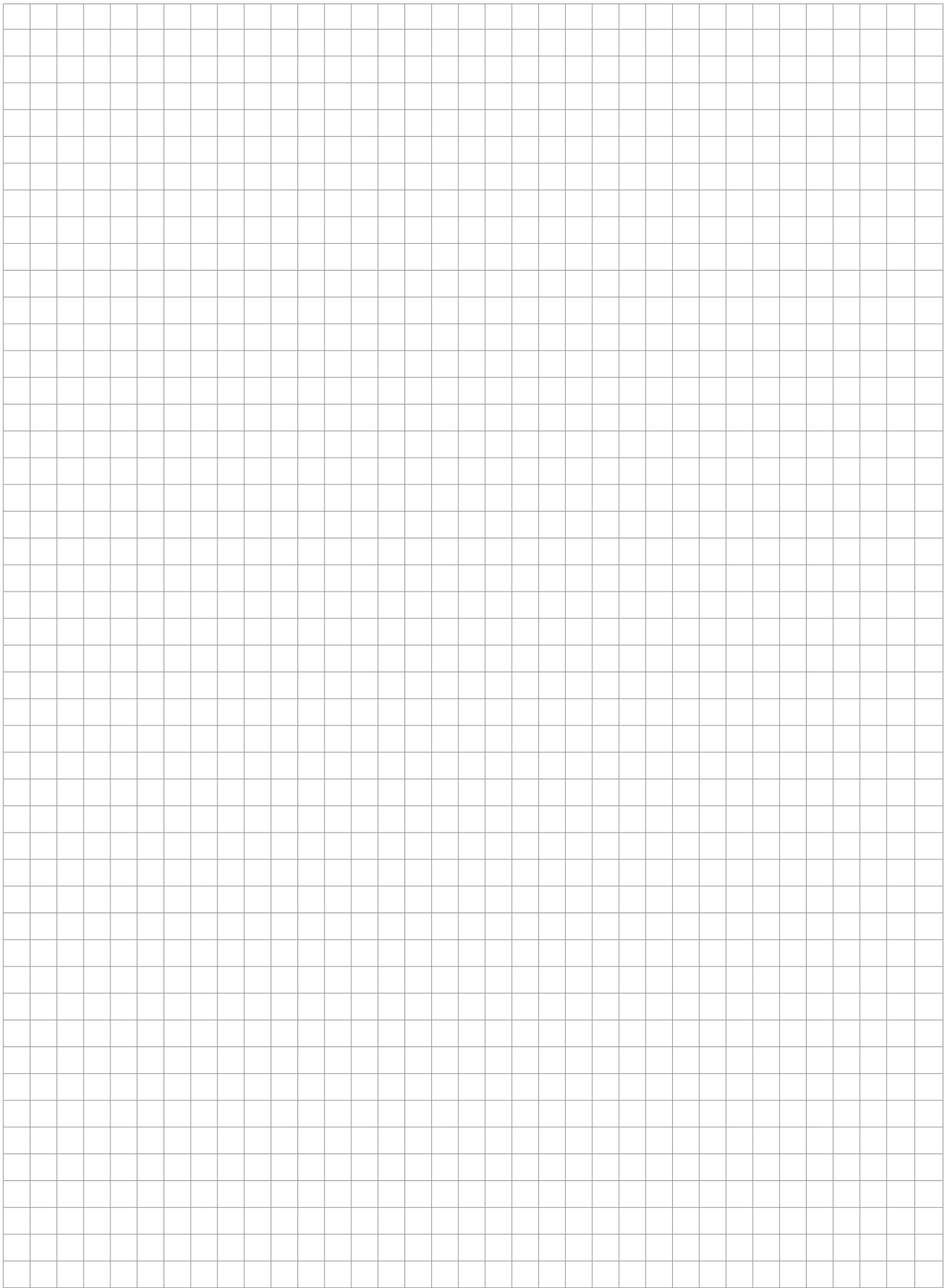

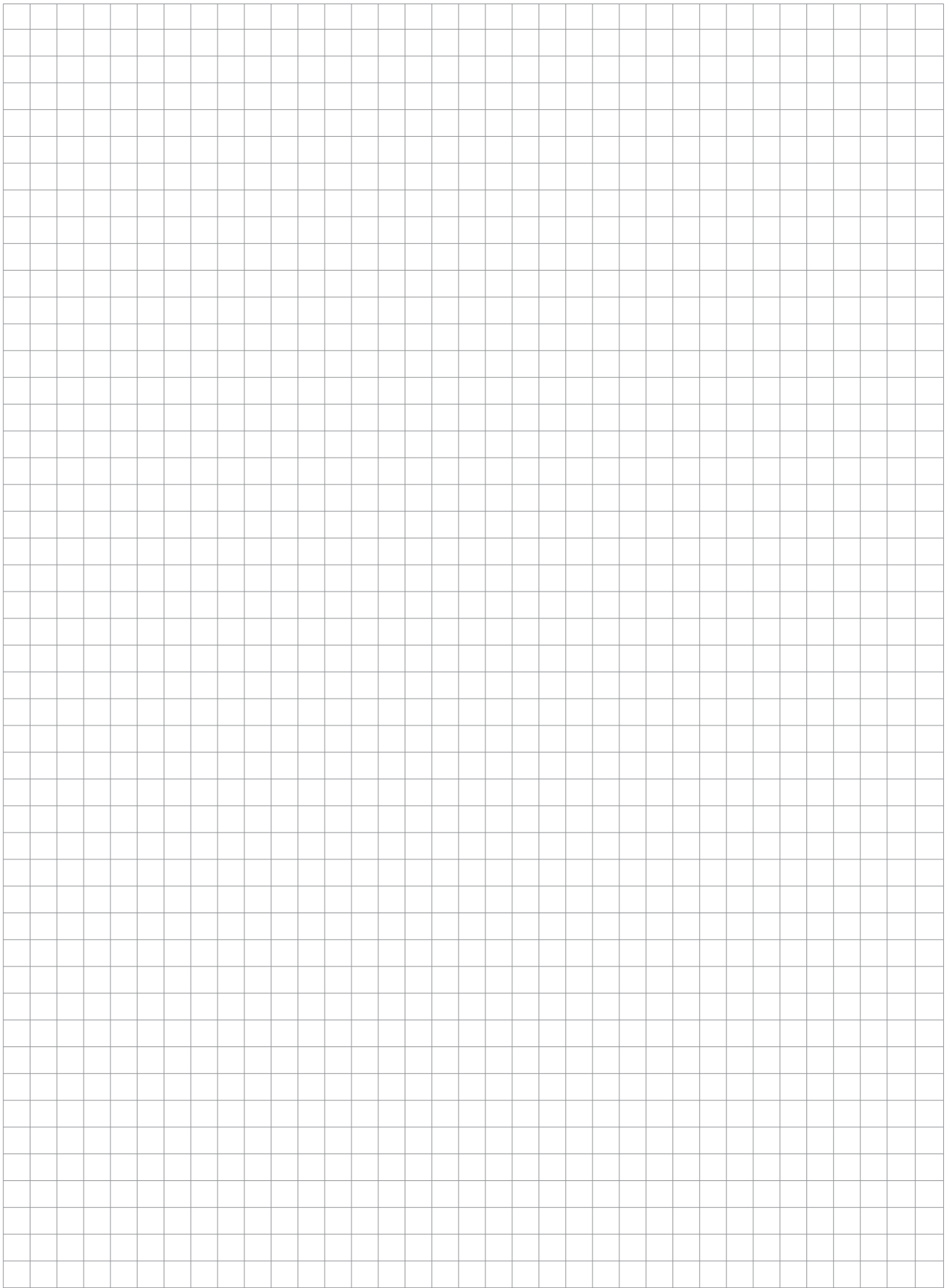

North America

Tel +1 800 545 6258
info@chemelex.com

Europe, Middle East, Africa, India

Tel +32 16 213 511
Fax +32 16 213 604
info@chemelex.com

Asia Pacific

Tel +86 21 2412 1688
infoAPAC@chemelex.com

Latin America

Tel +1 713 868 4800
info@chemelex.com

chemelex
excellence is everything

Raychem

Tracer

Pyrotenax

Nuheat