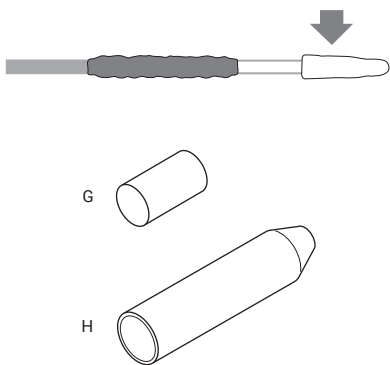
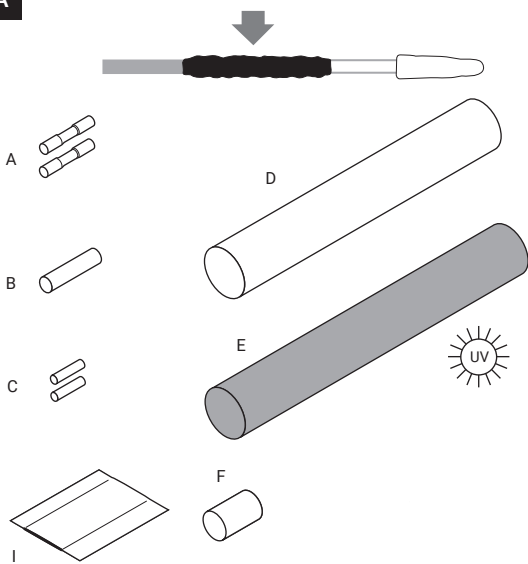
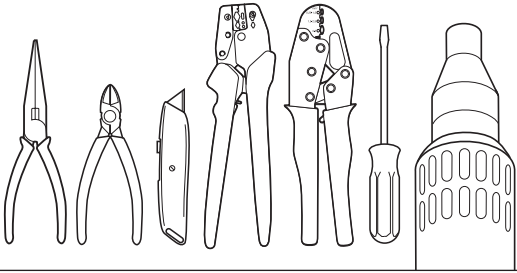
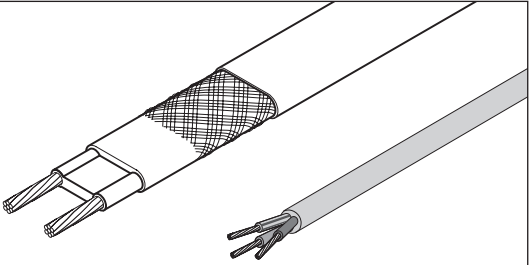

- EN** Cold Lead Connection and End Seal Kit
- DE** Anschlussgarnitur Für Zuleitungskabel Und Endabschlussgarnitur
- FR** Kit De Liaison Froide Et D'extrémité
- NL** Aansluiting- En Eindafwerkingset
- NO** Kaldkabelskjøt Og Endeavslutning Sett
- SV** Kalkabelanslutning Och Ändavslutningsatts
- DK** Kold Monteret Endeafslutning
- FI** Jatkospakkaus Kylmäkaapeliin Ja Loppupääte  
Kit Di Connessione E Terminazione
- PL** Zestaw Połączeniowy Z Przewodem Elektrycznym Zasilającym Oraz Zestaw Końcowy
- RU** Набор Для Подключения И Оконцевания Греющего Кабеля
- CZ** Připojovací Souprava Napájecího Kabelu A
- HU** Ukončovací Těsnění.  
Hideg-Vég Csatlakoztató És Véglezáró Készlet
- CR** Priključak Hladnog Kraja I Završna Garnitura

**A**

**B****C**

## ENGLISH

---

### A. Kit contents

---

A,B	Crimps
C,D,E,F	Cold lead shrinkable sleeves
G,H	End seal shrinkable sleeves
I	Mastic

---

## DEUTSCH

---

### A. Inhalt der Garnitur

---

A,B	Pressverbinder
C,D,E,F	Schrumpfschläuche für Zuleitungskabel
G,H	Schrumpfschläuche für Endabschluss
I	Abdichtmasse

---

## FRANÇAIS

---

### A. Contenu du kit

---

A,B	Manchons à sertir
C,D,E,F	Manchons thermorétractables pour liaison
G,H	Manchons thermorétractables pour l'extrémité
I	Mastic

---

## NEDERLANDS

---

### A. Inhoud kit

---

A,B	Krimpverbinders
C,D,E,F	Krimpkousen voor aansluiting
G,H	Krimpkousen voor eindafwerking
I	Mastiek

---

## NORSK

---

### A. Settet inneholder

---

A,B	Pressshylser
C,D,E,F	Krympestrømper til kaldkabel
G,H	Krympestrømper til endeavslutning
I	Mastic

---

## SVENSKA

---

### A. Satsinnehåll

---

A,B	Pressshylsor
C,D,E,F	Krympslangor för kallkabel
G,H	Krympslangor för ändavslutning
I	Mastik

---

## DANSK

---

### A. Komponentliste

---

A,B	Terminaler
C,D,E,F	Krympemuffe for kold kabel
G,H	Krympemuffe for endeaflutning
I	Mastik

---

## SUOMI

---

### A. Pakkaus sisältää

---

A,B	Liittimet
C,D,E,F	Kutistemuovit kylmäkaapelille
G,H	Kutistemuovit loppupäätteeseen
I	Tiiviste

---

## ITALIANO

### A. Contenuto del kit

A,B	Connettori
C,D,E,F	Termorestringenti per lato alimentazione
G,H	Termorestringenti per lato finale
I	Mastice

## POLSKI

### A. ZAWARTOŚĆ ZESTAWU

A,B	Złączeni zaciskowe
C,D,E,F	Rurki termokurczliwe połączenia zimnego
G,H	Rurki termokurczliwe
I	Mastyka

## РУССКИЙ

### A. В СОСТАВ НАБОРА ВХОДИТ

A,B	Обжимные гильзы
C,D,E,F	Усаживаемые трубки узла подключения
G,H	Концевые термоусаживаемые трубки Герметик
I	Герметик

## ČESKY

### A. SOUPRAVA OBSAHUJE

A,B	Lisovací spojovače
C,D,E,F	Smršťovací trubice pro připojení napájecího kabelu
G,H	Smršťovací trubice pro ukončení.
I	Těsnicí tmel

## MAGYAR

### A. KÉSZLET TARTALMA

A,B	Présselhető kötőelemek
C,D,E,F	Hőre zsugorodó csövek a hidegvéghez
G,H	Hőre zsugorodó csövek a véglezáráshoz
I	Tömítőanyag

## HVRATSKI

### A. SADRŽAJ GARNITURE

A,B	Presne spojnice
C,D,E,F	Stezne cijevi za hladni kraj
G,H	Stezne cijevi za završetak
I	Brtnvena masa

## ENGLISH

Applicable to following heating cables:	Cold lead cable:
<ul style="list-style-type: none"><li>• T2Red</li><li>• R-ETL-A</li><li>• R-ETL-B</li><li>• R-ETL-A-CR</li><li>• R-ETL-B-CR</li></ul>	<ul style="list-style-type: none"><li>• overall diameter: 6 mm - 11 mm.</li><li>• conductor size: 3 x 1,5 mm<sup>2</sup></li></ul>

WARNING: Please make sure the installation is carried out in clean, dry conditions and all cable ends are protected from moisture.

## NEDERLANDS

Toepasbaar op verwarmingskabels:	Aansluitkabel:
<ul style="list-style-type: none"><li>• T2Red</li><li>• R-ETL-A</li><li>• R-ETL-B</li><li>• R-ETL-A-CR</li><li>• R-ETL-B-CR</li></ul>	<ul style="list-style-type: none"><li>• buitendiameter: 6 mm - 11 mm.</li><li>• stroomdraadafmeting: 3 x 1,5 mm<sup>2</sup></li></ul>

OPGELET: De installatie moet worden uitgevoerd in droge en zuivere omstandigheden, en de kabeluiteinden moeten altijd tegen vocht beschermd worden.

## DEUTSCH

Für folgende Heizbänder geeignet:	Zuleitungskabel:
<ul style="list-style-type: none"><li>• T2Red</li><li>• R-ETL-A</li><li>• R-ETL-B</li><li>• R-ETL-A-CR</li><li>• R-ETL-B-CR</li></ul>	<ul style="list-style-type: none"><li>• Aussendurchmesser: 6 mm - 11 mm.</li><li>• Leiterquerschnitt: 3 x 1,5 mm<sup>2</sup></li></ul>

ACHTUNG: Bitte stellen Sie sicher, dass die Montage in sauberer und trockener Umgebung erfolgt und die Kabelenden vor Feuchtigkeit geschützt werden.

## NORSK

Til bruk for varmekabler	Kalkkabel:
<ul style="list-style-type: none"><li>• T2Red</li><li>• R-ETL-A</li><li>• R-ETL-B</li><li>• R-ETL-A-CR</li><li>• R-ETL-B-CR</li></ul>	<ul style="list-style-type: none"><li>• utvendig diameter: 6 mm - 11 mm.</li><li>• ledertverrsnitt: 3 x 1,5 mm<sup>2</sup></li></ul>

Advarsel: Utfør installasjonen under rene og tørre forhold, og forsikre at kabelendene ikke utsettes for fuktighet.

## FRANÇAIS

Compatible avec les rubans chauffants:	Câble de liaison froide:
<ul style="list-style-type: none"><li>• T2Red</li><li>• R-ETL-A</li><li>• R-ETL-B</li><li>• R-ETL-A-CR</li><li>• R-ETL-B-CR</li></ul>	<ul style="list-style-type: none"><li>• diamètre extérieur: 6 mm - 11 mm.</li><li>• Sections des conducteurs: 3 x 1,5 mm<sup>2</sup></li></ul>

Attention: Veiller à ce que l'installation soit réalisée dans un environnement propre et sec et que les extrémités du ruban soient protégées de l'humidité.

## SVENSKA

Passar till värmekablarna	Kalkkabel:
<ul style="list-style-type: none"><li>• T2Red</li><li>• R-ETL-A</li><li>• R-ETL-B</li><li>• R-ETL-A-CR</li><li>• R-ETL-B-CR</li></ul>	<ul style="list-style-type: none"><li>• ytterdiameter: 6 mm - 11 mm.</li><li>• ledararea: 3 x 1,5 mm<sup>2</sup></li></ul>

Varning: Säkerställ att installationen sker under rena, torra förhållanden och att värmekabeländarna skyddas mot fukt.

## DANSK

Anvendelig for varmekabel:	Kold kabel:
<ul style="list-style-type: none"><li>• T2Red</li><li>• R-ETL-A</li><li>• R-ETL-B</li><li>• R-ETL-A-CR</li><li>• R-ETL-B-CR</li></ul>	<ul style="list-style-type: none"><li>• Udvendig diameter: 6 mm - 11 mm.</li><li>• Tilslutning: 3 x 1,5 mm<sup>2</sup></li></ul>

Advarsel: Sørg for at montagen sker under rene og tørre forhold, samt at alle enderne på kablerne beskyttes mod fugt. Læs hele montagevejledningen inden arbejdet påbegyndes og følg instruktionerne nøje.

## POLSKI

Do stosowania z przewodami grzejnymi:	Przewody elektryczne (zimne)
<ul style="list-style-type: none"><li>• T2Red</li><li>• R-ETL-A</li><li>• R-ETL-B</li><li>• R-ETL-A-CR</li><li>• R-ETL-B-CR</li></ul>	<ul style="list-style-type: none"><li>• wymiary zewnętrzne: 6 mm-11 mm.</li><li>• średnica żyły: 3 x 1,5 mm<sup>2</sup></li></ul>

Uwaga: Montaż należy wykonywać w miejscu czystym, suchym a zakończenie przewodu grzejnego należy chronić przed wilgocią.

## SUOMI

Soveltuu lämpökaapeille:	Kylmäkaapeli:
<ul style="list-style-type: none"><li>• T2Red</li><li>• R-ETL-A</li><li>• R-ETL-B</li><li>• R-ETL-A-CR</li><li>• R-ETL-B-CR</li></ul>	<ul style="list-style-type: none"><li>• kokonaishalkaisija: 6 mm - 11 mm.</li><li>• johtimen koko: 3 x 1,5 mm<sup>2</sup></li></ul>

Varoitus: Varmista että asennus tehdään puhtaissa, kuivissa olosuhteissa ja kaapelin päät on suojattu kosteudelta.

## РУССКИЙ

Применяется для греющих кабелей:	Силовой кабель
<ul style="list-style-type: none"><li>• T2Red</li><li>• R-ETL-A</li><li>• R-ETL-B</li><li>• R-ETL-A-CR</li><li>• R-ETL-B-CR</li></ul>	<ul style="list-style-type: none"><li>• Внешний диаметр: 6 mm - 11mm.</li><li>• Сечение жилы: 3 x 1,5 mm<sup>2</sup></li></ul>

ВНИМАНИЕ: монтаж должен производиться в чистых, сухих условиях; греющий кабель должен храниться с защищенными от влаги концами.

## ITALIANO

Adatto ai cavi scaldanti:	Cavo di potenza:
<ul style="list-style-type: none"><li>• T2Red</li><li>• R-ETL-A</li><li>• R-ETL-B</li><li>• R-ETL-A-CR</li><li>• R-ETL-B-CR</li></ul>	<ul style="list-style-type: none"><li>• diametro esterno: 6 mm - 11 mm.</li><li>• dimensione del conduttore: 3 x 1,5 mm<sup>2</sup></li></ul>

Attenzione: Assicurarsi che l'installazione venga effettuata in ambiente asciutto E, pulito E che tutte le terminazioni dei cavi siano protette dall'umidità.

## ČESKY

Souprava je určena pro topné kabely:	Napájecí kabel:
<ul style="list-style-type: none"><li>• T2Red</li><li>• R-ETL-A</li><li>• R-ETL-B</li><li>• R-ETL-A-CR</li><li>• R-ETL-B-CR</li></ul>	<ul style="list-style-type: none"><li>• Vnější průměr: 6 mm - 11 mm.</li><li>• průřez vodiče: 3 x 1,5 mm<sup>2</sup></li></ul>

UPOZORNĚNÍ: Zajistěte, aby montáž byla prováděna v čistém a suchém prostředí, všechny konce kabelů chraňte před vlhkostí.

## MAGYAR

Fűtőkábel:	Hidég-vég kábel:
<ul style="list-style-type: none"><li>• T2Red</li><li>• R-ETL-A</li><li>• R-ETL-B</li><li>• R-ETL-A-CR</li><li>• R-ETL-B-CR</li></ul>	<ul style="list-style-type: none"><li>• külső átmérő: 6 mm - 11 mm.</li><li>• vezető méret: 3 x 1,5 mm<sup>2</sup></li></ul>

**FIGYELMEZTETÉS:** A szerelést tiszta és száraz körülmények között kell végezni és minden kábelvégződés legyen védett a nedvességtől.

## HVRATSKI

Grijači kabeli:	Napojni kabel (hladni kraj):
<ul style="list-style-type: none"><li>• T2Red</li><li>• R-ETL-A</li><li>• R-ETL-B</li><li>• R-ETL-A-CR</li><li>• R-ETL-B-CR</li></ul>	<ul style="list-style-type: none"><li>• Vanjski promjer: 6 mm - 11 mm.</li><li>• Presjek: 3 x 1,5 mm<sup>2</sup></li></ul>

**UPOZORENJE:** Paziti da se montaža vrši u čistim i suhim uvjetima, te da su svi završeci zaštićeni od vlage.

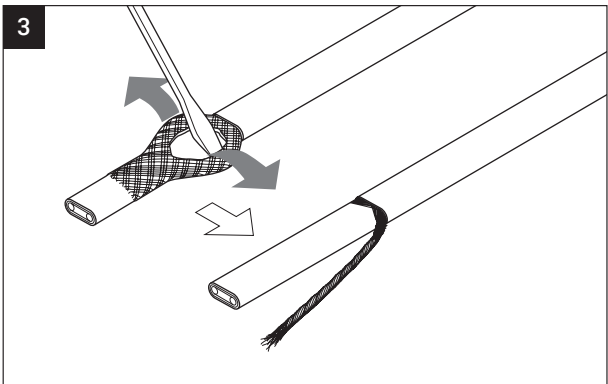
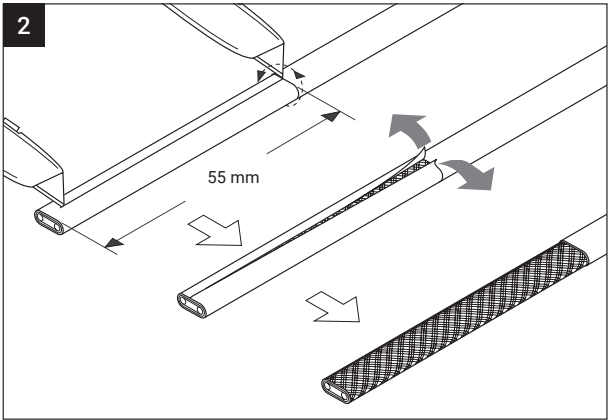
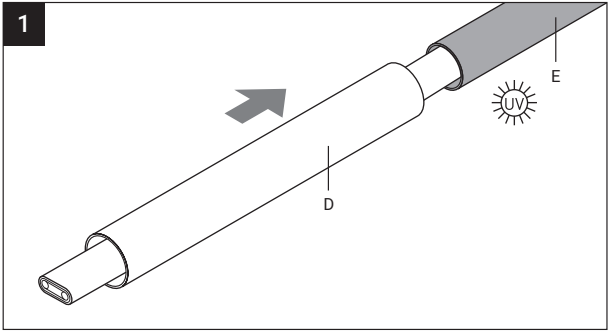

4

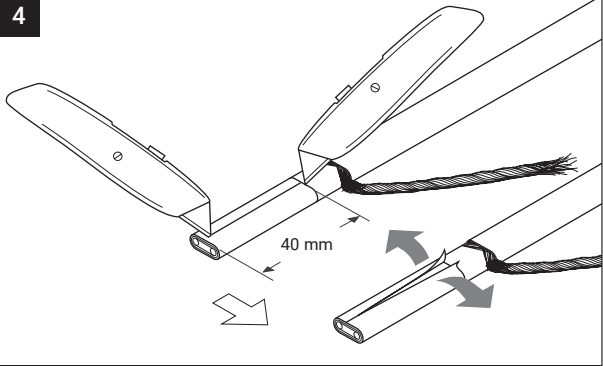

5

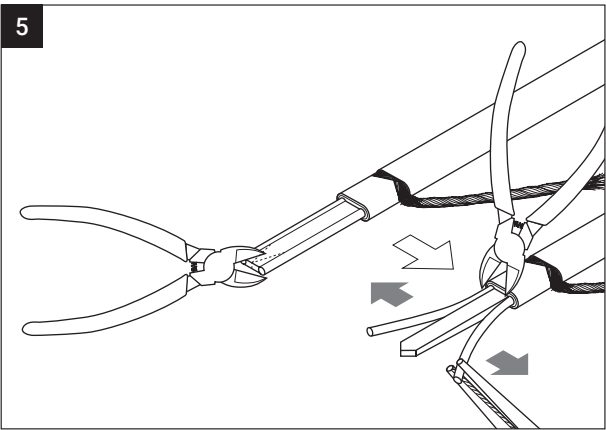

6

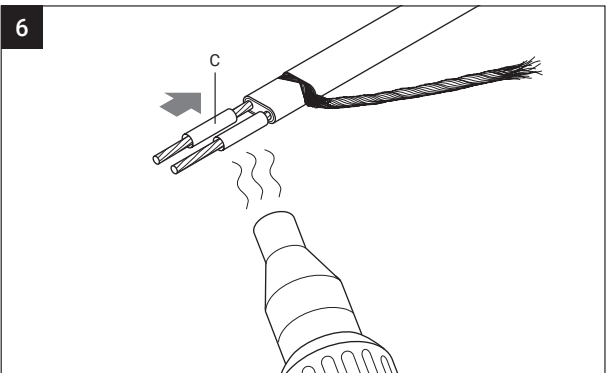

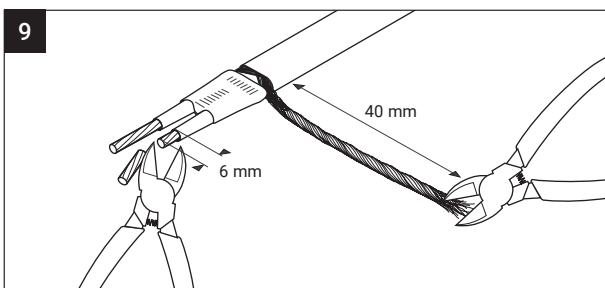
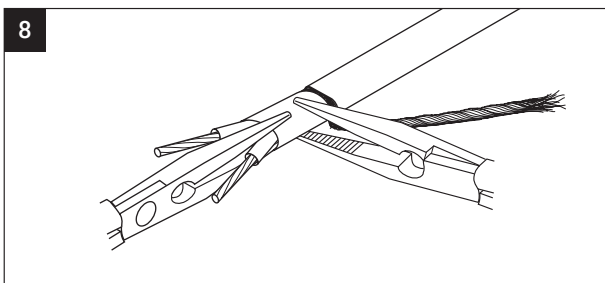
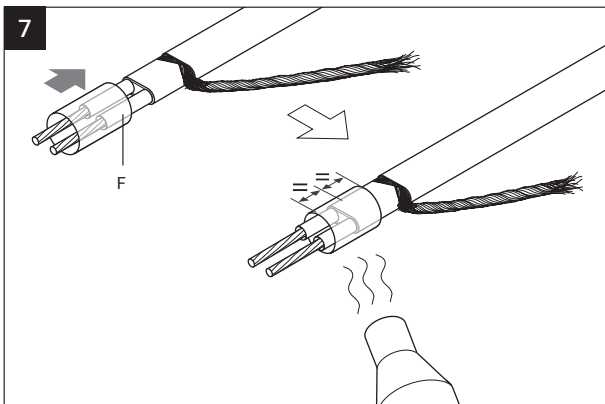

10

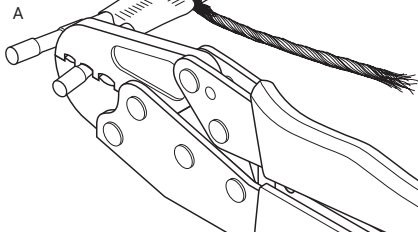

11

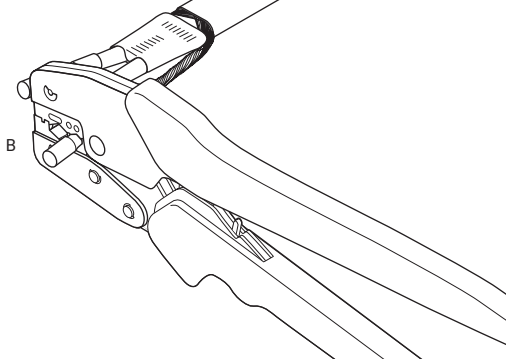

12

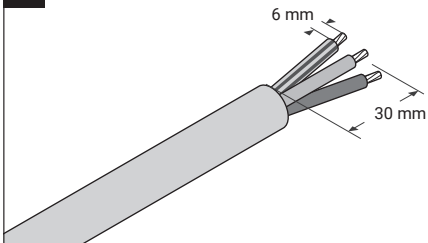

13

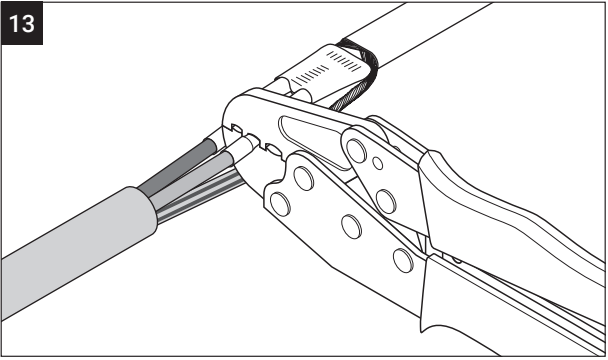

14

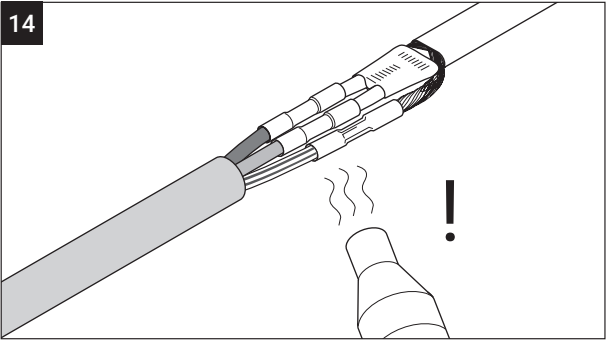

15

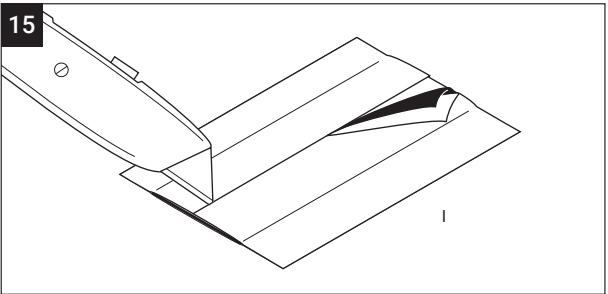

16

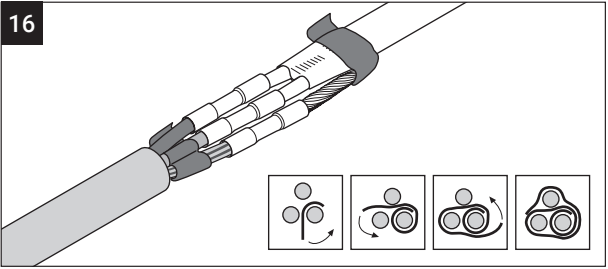

17

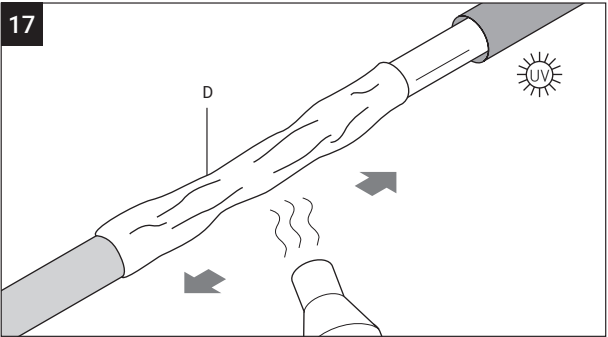

18

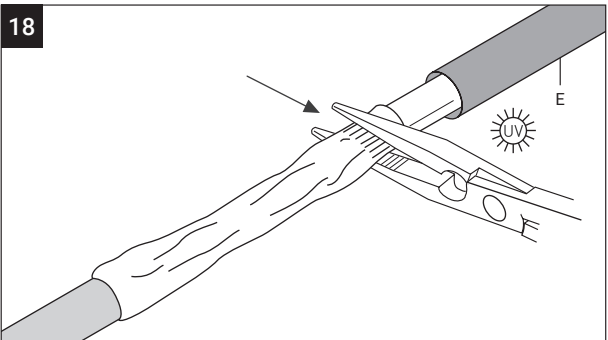

19

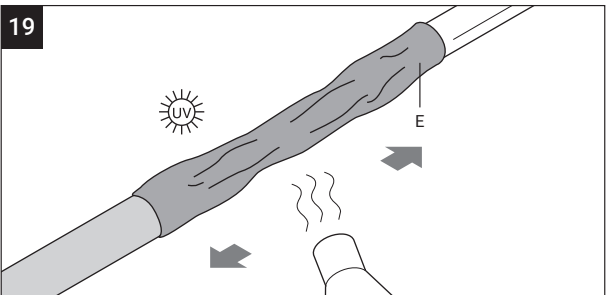

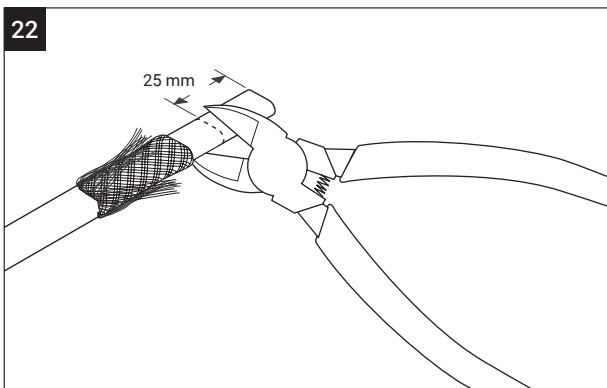
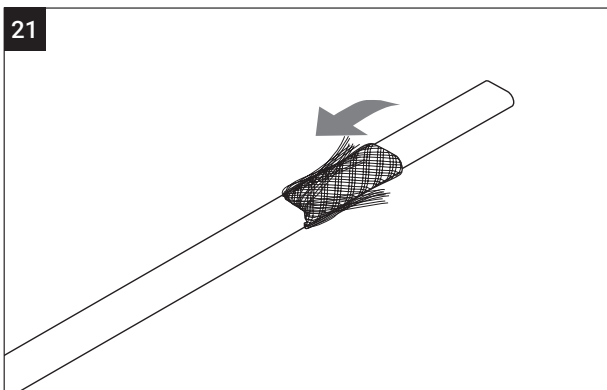
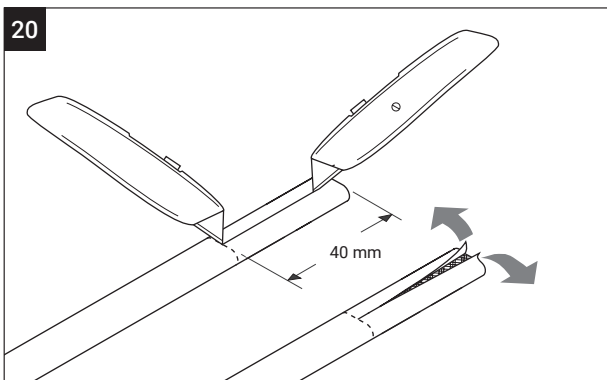

23

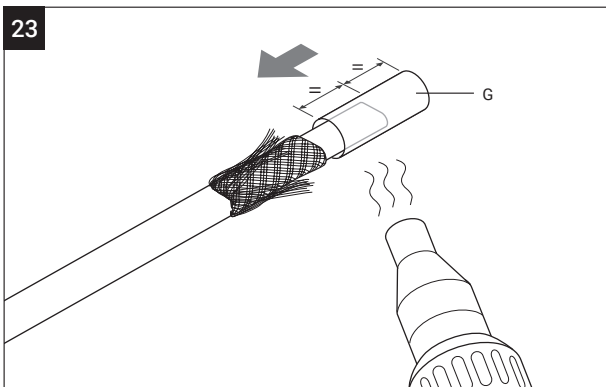

24

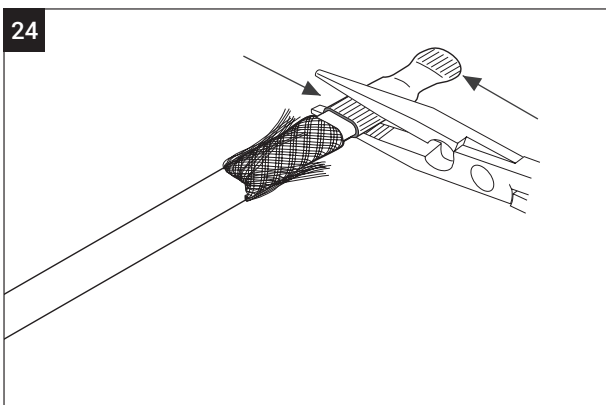

25

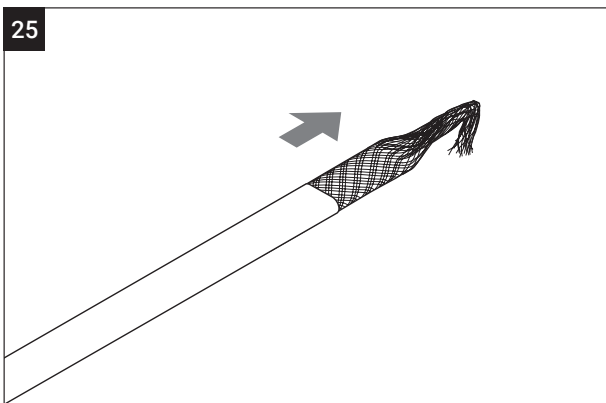

26

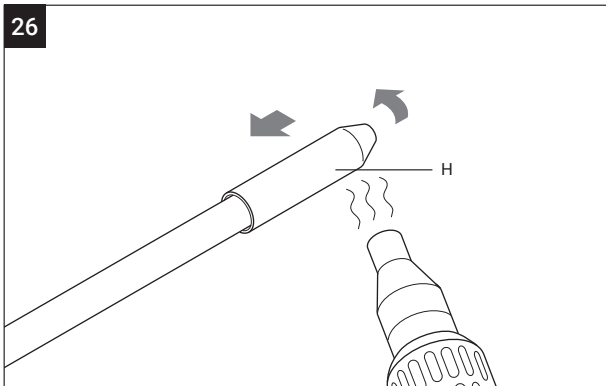

27

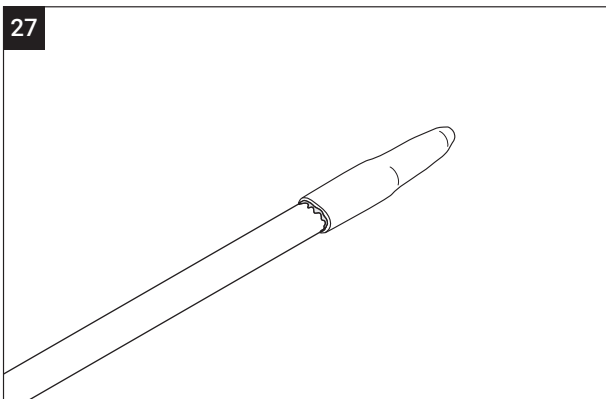

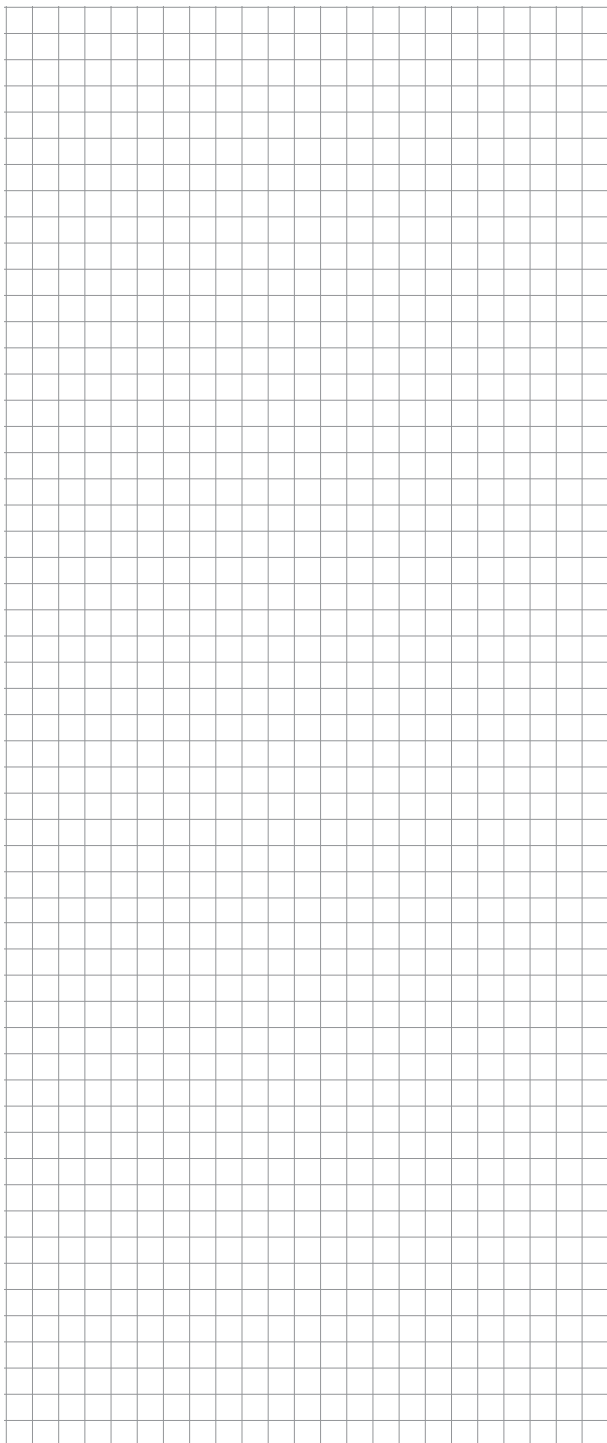

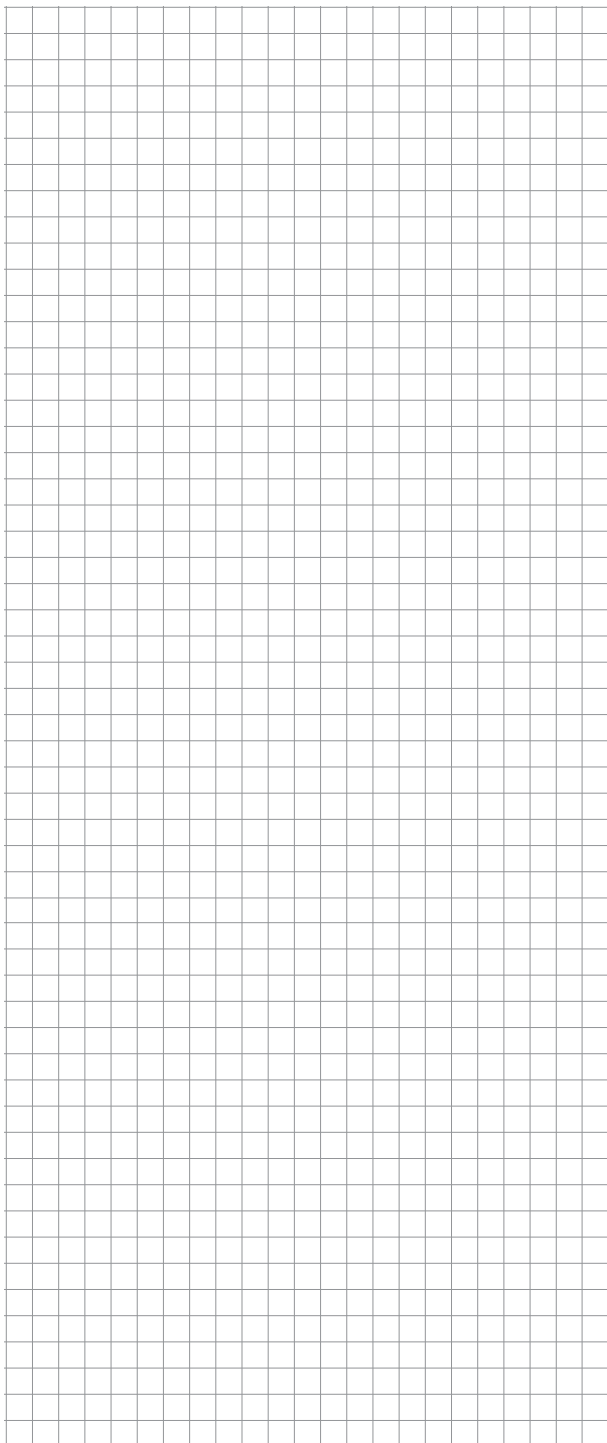

## **België / Belgique**

Tel +32 16 21 35 02  
Fax +32 16 21 36 04  
SalesBelux@chemelex.com

## **Bulgaria**

Tel +359 2 973 33 73  
SalesEE@chemelex.com

## **Česká Republika**

Tel +420 606 069 618 (Comm)  
+420 602 232 969 (Ind)  
infoCZ@chemelex.com

## **Danmark**

Tel +45 70 11 04 00  
SalesDK@chemelex.com

## **Deutschland**

Tel 0800 181 82 05  
SalesDE@chemelex.com

## **España**

Tel +34 911 59 30 60  
Fax +34 900 98 32 64  
SalesES@chemelex.com

## **France**

Tél 0800 90 60 45  
SalesFR@chemelex.com

## **Hrvatska**

Tel +385 51 225 073 (Comm)  
+385 1 605 01 88 (Ind)  
SalesEE@chemelex.com

## **Italia**

Tel +39 02 577 61 51  
Fax +39 02 577 61 55/28  
SalesIT@chemelex.com

## **Lietuva/Latvija/Eesti**

Tel +370 698 411 56  
SalesEE@chemelex.com

## **Magyarország**

Tel +36 1 253 76 17  
SalesHU@chemelex.com

## **Nederland**

Tel 0800 022 49 78  
SalesNL@chemelex.com

## **Norge**

Tel +47 66 81 79 90  
SalesNO@chemelex.com

## **Österreich**

Tel 800 29 74 10  
SalesAT@chemelex.com

## **Polska**

Tel +48 22 331 29 50  
Fax +48 22 331 29 51  
SalesPL@chemelex.com

## **Казакстан**

Tel +7 7112 31 67 03170  
SalesKZ@chemelex.com

## **Serbia and Montenegro**

Tel +386 41 665 634 (Comm)  
+381 230 439 519 (Ind)  
SalesEE@chemelex.com

## **Schweiz / Suisse**

Tel +41 (41) 766 30 80  
Fax +41 (41) 766 30 81  
infoCH@chemelex.com

## **Suomi**

Puh 0800 11 67 99  
SalesFI@chemelex.com

## **Sverige**

Tel +46 31 335 58 00  
SalesSE@chemelex.com

## **Türkiye**

Tel +90 545 284 09 05  
SalesEE@chemelex.com

## **UK/Ireland**

Tel 0800 969 013  
SalesUK@chemelex.com

---

**chemelex**  
excellence is everything

chemelex.com

**Raychem Tracer Pyrotenax Nuheat**

©2025 Chemelex. All Chemelex marks and logos are owned or licensed by Chemelex Europe GmbH or its affiliates. All other trademarks are the property of their respective owners. Chemelex reserves the right to change specifications without notice.

RAYCHEM-IM-INST277-UACCP07-ML-2504

PCN 1244-004974