

Raychem

HWAT-System

Installation and
Maintenance Manual

Hot water temperature maintenance
system-HWAT for pipes with thermal insulation

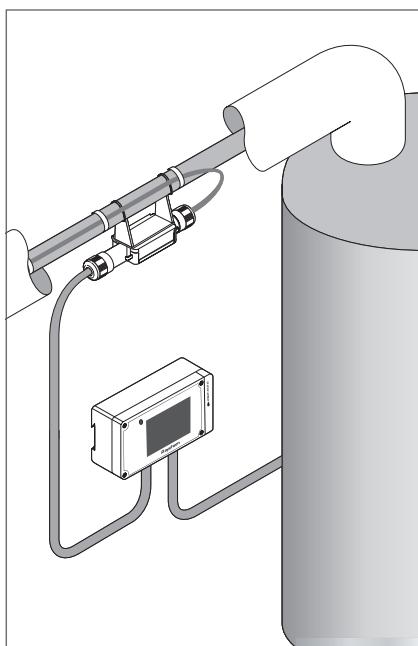

IMPORTANT NOTES

Thermal Insulation

All heat-traced pipes and equipment must be thermally insulated. The insulation is a very important part of the Raychem HWAT system, to ensure its effective operation.

Safety warnings



The following instructions must be followed to avoid fires or electric shock as well as to satisfy the Chemelex warranty conditions and the requirements of the product approvals.

Raychem HWAT Systems must be installed correctly to ensure proper operation and to prevent shock and fire. Read these important warnings and carefully follow all the installation instructions.

- Chemelex require the installation of a 30 mA fault current circuit breaker for circuit protection in case of damaged or incorrectly installed heat-tracing cables.
- Warranty claims may be levied against Chemelex only if the parts specified by Chemelex have been used exclusively. Do not use untested material and/or material not manufactured by Chemelex in the temperature maintenance system.
- Core wires will short if they contact each other. Avoid contact of the core wires (Also known as Bus wires.) Connection kits and cable ends must be kept dry before and during installation.
- The black heating-cable core is conductive and can short. It must be properly insulated and kept dry.
- Damaged bus wires can overheat or short. Do not break bus wire strands when preparing the cable for connection.
- Damaged heating cables can cause electrical arcing or fire. Do not use metal attachments such as pipe straps or tie wire. Use only Chemelex approved adhesive tapes and cable ties to fasten the cable to the pipe.
- Damaged cables may not be energised or repaired by unauthorised persons. Remove the damaged heating cables immediately and replace them with a new cable of the appropriate length.
- Use the Raychem RayClic-S-02 connection kit. Replace damaged connection kits.
- Only use pipe insulating materials suitable for this application according to the local regulations.

1	General information	4
2	Heat-tracing cable selection	8
3	Heat-tracing cable installation	9
4	HWAT components	13
5	Controlling and monitoring	15
6	Thermal insulation	16
7	Power supply and electrical protection	19
8	Commissioning	20
9	Troubleshooting	23
10	List of possible faults	26
11	Installation and test sheet	30

1 GENERAL INFORMATION

1.1 Use of the manual

This installation and operation manual is for Raychem HWAT Hot Water Temperature Maintenance systems installed on thermally insulated pipes only.

This manual details how to install and operate a HWAT system. The HWAT system includes the heattracing cables HWAT-L, HWAT-M and HWAT-R, RayClic connection kits and the Raychem HWAT-ECO control unit. It is important to review this manual and the following documents with the installation contractor.

- Product selection and design guidance for the HWAT system according to specifications in the technical manual (CDE-517)
- Installation instructions for the Raychem RayClic connection kit (INST-168)
- HWAT-ECO Installation and Operation Manual (EU0932)
- Safety Warnings (INST-193)

Further information: see overleaf

1.2 Safety guidelines

The safety and reliability of heat-tracing systems depends on the quality of the products selected, and on proper planning, installation and maintenance. A faulty design, incorrect handling, improper installation or maintenance of a system component can lead to the pipe being heated too little or too much. This can also cause damage to the temperature maintenance system which may lead to system failure, electric shock or fire. The guidelines and instructions contained in this guide are important. Follow them carefully to minimise these risks and to ensure that the HWAT System performs reliably.

1.3 Typical HWAT system

A typical HWAT System is shown in Figure 1 below. The heat-tracing cable is cut to length in the field and is attached to the pipe with cable ties. The heat tracing cable connections are made using a connection kit. Connection kits accommodate pipe branches to connect two or three heat-tracing cables together. The heat tracing cables are terminated using an end seal. A control unit is used to set the maintain temperature and facilitate energy savings.

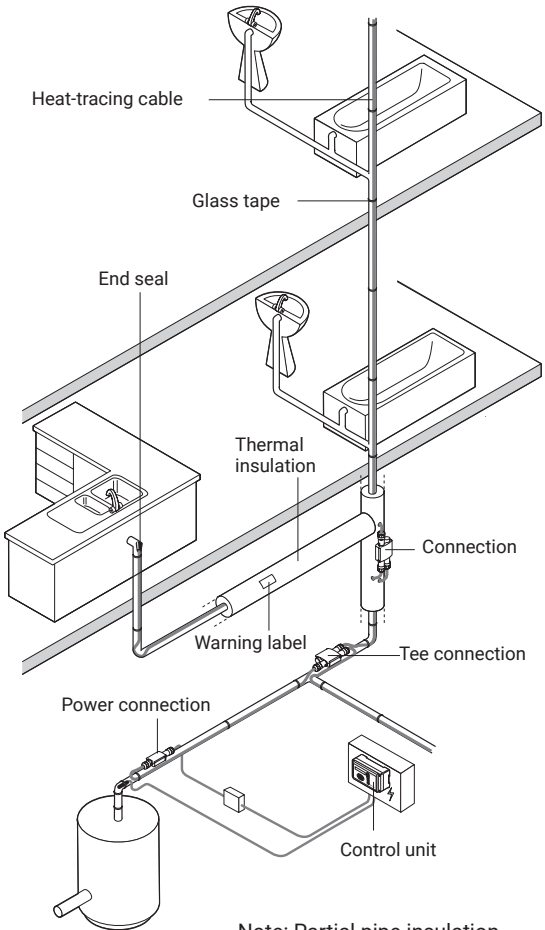

Note: Partial pipe insulation shown here for clarity. All pipes must be insulated at least according to the specified regulations.

Figure 1: Typical HWAT heat-tracing cable system

1.4 Electrical codes

All installations must comply with the local regulations, technical connection conditions and specifications.

1.5 Approvals

The heat-tracing cables HWAT-L, HWAT-M and HWAT-R, the RayClic connection kits and the HWAT-ECO are only approved for use in non-hazardous areas. Refer to the specific product data sheets for details.

1.6 Warranty

The warranty conditions for Europe must be taken from the respective terms of sale and delivery specific to the country.

1.7 Co-ordination of the different trades

Installation of an HWAT system can involve or impact the work of numerous trades. Therefore, effective and early coordination between trades is a critical aspect of all HWAT System Installations. The installation of the heat-tracing cables and connections must be carefully planned. This also applies to the risers and installation of the insulation.

This manual guides the installation technician through the installation process. All the affected trades should therefore read it carefully before starting installation of the HWAT system. In a “fast-track” job, the HWAT System must be considered a critical path item: pipe, heat-tracing cable and insulation must be installed in the right order. If, for example, the walls are constructed before the heat-tracing cable has been tested, it may be necessary to open the walls again in order to repair a damaged or improperly installed system.

Ensuring that the installation of the HWAT System is included in the overall construction schedule will help ensure a successful and trouble-free installation.

1.8 General installation notes

Read and observe the instructions in this guide to insure that the HWAT System is installed successfully.

- Please read the installation instruction carefully in order to get familiar with the system components.
- **All heat-traced pipes and equipment must be thermally insulated. Insulation is an important part of the HWAT System. For an effective system, the heat loss must be checked for each specific pipe size as detailed in Table 2, page 16.**
- To minimise the risk of damage to the heat-tracing cables, the insulation must be installed immediately after testing the heat-tracing cables.
- Do not install the HWAT System below the minimum installation temperature.
- The minimum installation temperature for HWAT cables and RayClic is -10°C .
- The minimum installation temperature for HWAT-ECO is 5°C .
- Ensure that your water heater temperature is set at your desired pipe maintain temperature.
- Do not energise the heat-tracing cable when it is coiled or on the reel.
- Never use metal tie wire or pipe straps to secure heat-tracing cables to pipes.



Note: If the hot water tank temperature exceeds 65°C in the HWAT-L/-M or 80°C in the HWAT-R, the heater life expectancy may be affected.

1.9 Tools required

For installing heat-tracing cables and connection kits:

- Knife
- Wire cutters
- Tape measure
- Torx T20 screwdriver
- Electrical hot-air gun ($>2\text{kW}$) or propane gas burner (when using shrink kits)

For testing the heat-tracing cable:

- Insulation tester 2500VDC (recommended) but 500 VDC at least
- Multimeter (voltage, resistance and capacitance)
- Temperature measuring device
- Infrared thermometer, e.g. the Raychem CDE-IR-Temp

2 HEAT-TRACING CABLE SELECTION

2.1 Heat-tracing cables

The HWAT System includes HWAT-L/-M and HWAT-R heat-tracing cables designed to maintain the piping at specific temperature settings with the use of the HWAT-ECO control unit.

Figure 2 shows the structure of the heat-tracing cables.

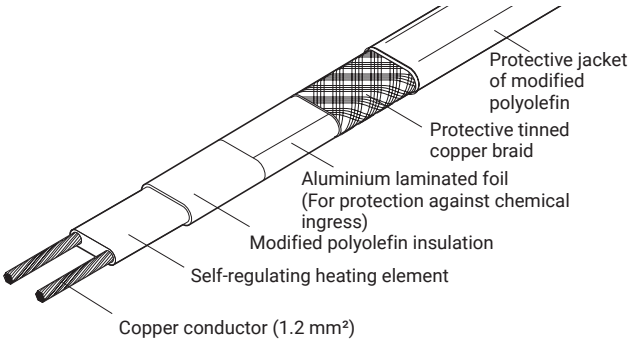

Figure 2: Raychem HWAT

3 HEAT-TRACING CABLE INSTALLATION

3.1 Heat-tracing cable storage

- Store the heat-tracing cable in a clean, dry location. Temperature range: -40°C to 60°C
- Protect the heat-tracing cable from mechanical damage and moisture.

3.2 Pre-installation testing

Check materials received:

- Review the HWAT cable design and compare the list of materials to the catalogue numbers of the heat-tracing cables and connection kits received to confirm that the proper materials are on site. The HWAT cable type is printed on its jacket.
- The HWAT System is limited to 230 V service when using the HWAT-ECO control unit. Ensure that the service voltage available is correct.
- Inspect the heat-tracing cable and connection kits to ensure there is no in-transit damage.
- Make sure that the inner jacket of the heat-tracing cables is not damaged. Carry out an insulation resistance check on every reel for this (see section 9). Do not power the heat-tracing cable when it is on the reel..

Check the pipe:

- Make sure that all mechanical pipe tests (i.e. hydraulic pressure test/rinsing) have been carried out completely and the pipe fittings are finally tightened.
- Walk the system and plan the routing of the heat tracing cable on the pipe.
- Inspect the piping and remove any burrs, rough surfaces or sharp edges..

3.3 Installation

- Reel off the heat-tracing cable. Pull it loosely along the pipe. Make sure that the heat-tracing cable always runs along next to the pipe when there are obstructions.
- Install the cable in straight runs along the pipe. Spiralling the heat-tracing cable is not necessary.
- When installing the heat-tracing cable, the cable must not be compressed or pinched between two objects. Wall and floor penetrations and pipe straps are particular areas of concern.

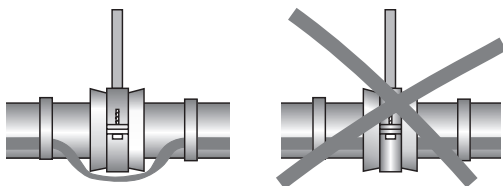

Figure 3: Feed cable over pipe hangers, do not trap the cable!

- When making floor or wall penetrations, make sure the aperture is large enough to accommodate the pipe and the thermal insulation. When sealing around pipes at floor penetrations, avoid damaging or cutting the heat-tracing cable, or pinching it between the pipe and the concrete.
- The heat-tracing cable may not be embedded directly in the sealing material. The pipe must be fitted with a thermal insulation (if the local regulations allow) or the heat-tracing cable must be laid in a pipe or protective conduit through the aperture. If the conduit must be sealed, use an appropriate fire resistant material (Dow Corning Fire Stop, 3M Fire Barrier, or T&B Flame-Safe) that can be removed if necessary.
- On vertical piping groups, run the heat-tracing cable along the inside of the pipe close to other pipes so it will not be damaged if the pipe hits the side of the floor aperture. Run the heat-tracing cable over the outside of the pipe support. Do not clamp the heat-tracing cable to the pipe with the pipe support.

Reeling out the heat-tracing cable:

- Use a reel holder that spools out smoothly with little tension. If the heat-tracing cable snags, stop pulling.
- Keep the heat-tracing cable attached loosely but close to the pipe being traced to avoid interference with supports and equipment.
- Metre marks on the HWAT cable make it easier to determine the length of the heat-tracing cable.
- Protect all heat-tracing cable ends from moisture, contamination and mechanical damage.

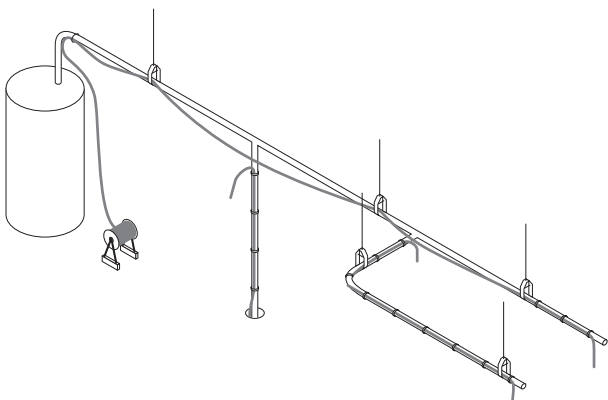

Figure 4: HWAT cable layout

When reeling out the heat-tracing cable, AVOID:

- Sharp edges
- Excessive pulling force or over-tensioning
- Kinking and crushing
- Other mechanical damage (ie. walking on it, or running over it with equipment)

Positioning of heat-tracing cables

If possible, position the heat-tracing cable on the lower section of the pipe, at the 4 or 8 o'clock positions, as shown below, to protect it from damage.

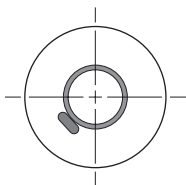

Figure 5: Positioning heat-tracing cable

Bending the heat-tracing cable

When positioning the heat-tracing cable on the pipe, do not bend tighter than 10 mm radius. The heat-tracing cable does not bend in the flat plane. Do not force such a bend, as the heat-tracing cable will be damaged.

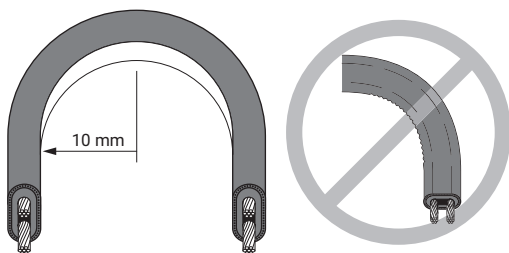

Figure 6: Bending technique

Crossing the heat-tracing cable

Heat-tracing cables are self-regulating and may be overlapped if necessary without the risk of overheating.

Cutting the heat-tracing cable

Cut the heat-tracing cable to the desired length after it is attached to the pipe. HWAT can be cut to length without affecting the heat output.

Attachment tapes

To make sure that the heat-tracing cable comes properly into contact with the pipe, fix it to the pipe with KBL-10 cable ties or use the Raychem GT-66 glass tape on plastic, iron or copper pipes. Please use the Raychem GS-54 glass tape on stainless steel pipes.

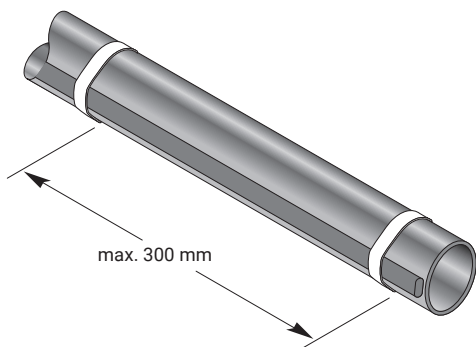

Figure 7: Fastening the heat-tracing cable

⚠ CAUTION: Do not use metal attachments such as pipe straps or tie wire. Do not use untested adhesive tapes. Use only fastening materials approved by Chemelex and listed in the Technical Manual.

4 HWAT COMPONENTS

4.1 General connection kit information

Raychem RayClic connection kits must be used with HWAT heat-tracing cables. A complete circuit requires a power connection and an end seal. Splices and tees and other connection kits are used as needed. Select the suitable connection kits using the Technical Manual for heat-tracing cables and frost protection systems. Installation instructions are included with every connection kit. Steps for preparing the heat-tracing cable and installing connection kits must be followed. The layout of the connection kits should be noted on the revision plans.

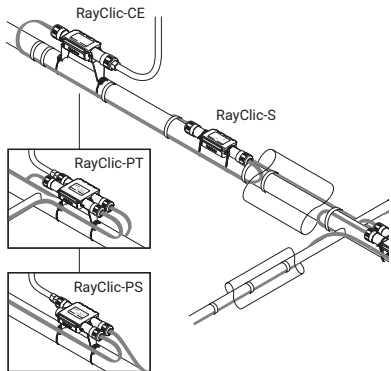

Figure 8: RayClic connection system

Connection kit Installation

- Always install the connection kits so that they are accessible at all times.

Table 1: HWAT cable allowances for connector installation

Connection kit name	Number of cable entries	additional cable length
RayClic-CE	1	0,3 m
RayClic-S	2	0,6 m
RayClic-T	3	1,0 m
RayClic-X	4	1,2 m
RayClic-PS	2	0,6 m
RayClic-PT	3	1,0 m
RayClic-E	1	NA

- Provide access to each connection kit to simplify maintenance on the systems.
- Locate electrical junction boxes for easy access but not where they may be exposed to mechanical abuse.
- Heat-tracing cables must be installed above and not below pipe straps..

⚠ CAUTION: The black heat-tracing cable core is electrically conductive and can short. It must be properly insulated and kept dry. Damaged bus wires can overheat or short.

⚠ CAUTION: Raychem specified components must be used. Do not replace Raychem components with untested components.

5 CONTROL AND MONITORING

5.1 Raychem HWAT-ECO Control Unit

The Raychem HWAT-ECO control unit is designed exclusively for using with the HWAT-M and HWAT-R heat-tracing cables. It is used to optimise the HWAT temperature maintenance system. Refer to the HWAT-ECO Installation and Operation Manual for the installation and operation instructions of the control unit (EU0932).

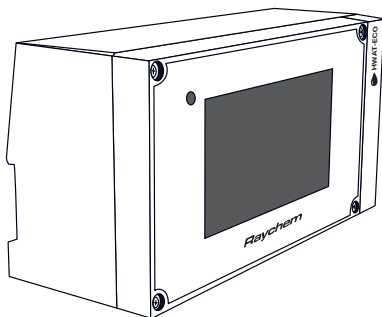
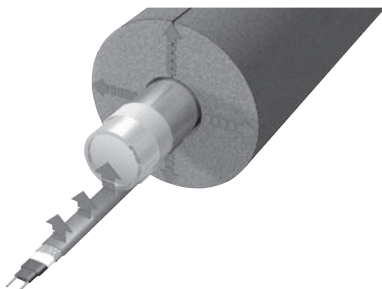

Figure 9: Control unit HWAT-ECO

6 THERMAL INSULATION

6.1 Insulating the system

Pipes must be insulated with the correct thermal insulation to maintain the desired pipe temperatures.



A good thermal insulation means

- Lower heat losses
- Lower operating costs

The data in table 2 can also be used as a guideline.

Table 2: Heat losses: Select the cable type based on its power to compensate the heat loss

Heat losses in W/m, pipe 55°C in 18°C environment

Insulation Type	DN 15	DN 20	DN 32	DN 40	DN 50
15 mm	10	12	16	18	21
20 mm	9	10	14	15	18
30 mm	7	8	11	12	14
40 mm	6	7	9	10	12
50 mm	6	7	8	9	10
60 mm	5	6	8	8	9

Heat losses in W/m, pipe 55°C in 5°C environment

Insulation Type	DN 15	DN 20	DN 32	DN 40	DN 50
15 mm	13	16	21	24	28
20 mm	12	13	18	20	23
30 mm	10	11	14	16	18
40 mm	8	10	12	13	15
50 mm	8	9	11	12	13
60 mm	7	8	10	11	12

Note: Table 2 is based on calculations with the Raychem-Software TraceCalc® pro with the following parameters:

- Maintain temperature 55°C
- Building inside room
- Safety factor 10%
- Rockwool, heat conductivity λ 0.041 W/mK at 40°C

Table 3: Minimum insulation thickness used with HWAT systems

Insulation thickness						
Pipe size (mm)	15	22	28	35	42	54
Insulation thickness (mm)	20	20	25	30	40	50

Ambient temperature: 18°C

Thermal conductivity $\lambda = 0.035$ W/(m.K)

For other thermal conductivity insulation materials, contact your Chemelex representative.

6.2 Insulation installation

- Before insulating the pipe, visually inspect the heattracing cable and connection kits to ensure they are properly installed and there are no signs of damage. Damaged cable or connection kits must be replaced.
- Check the insulation type and its thickness comply with the configuration principles and local insulation regulations.
- Insulate the pipes immediately after the heattracing cable is installed and has passed all tests to minimise the risk of possible damage to the heattracing cable.
- Also insulate the pipe in floor and wall penetrations. Failure to do so will lead to cold places on the water system and/or possible damages to the heat-tracing cable.
- Do not use staples to close the insulation. Use tape or the adhesive-lined edge of the insulation to ensure that the seam remains sealed. Staples can damage the HWAT heat-tracing cable.

- Make sure that all heat-traced pipes are insulated. Correct temperature maintenance requires properly installed and dry thermal insulation. Uninsulated sections of pipe can result in heat losses.
- After installing insulation, electrical codes require that you install “Electric Traced” labels along the piping at suitable intervals (5 m intervals recommended) on alternate sides.

⚠ CAUTION: Only use thermal insulation approved for hot water pipes according to local insulation regulations.

7 POWER SUPPLY AND ELECTRICAL PROTECTION

7.1 Voltage rating

Verify that the supply voltage is AC 230V as specified by the HWAT System design.

7.2 Power circuit breaker sizing

Power circuit breakers must be adapted to the heat tracing cable lengths specified in table 3. Do not exceed the maximum circuit length specified for every power circuit breaker size. Use residual current devices with ground fault protection of 30 mA.

Table 4: Max. circuit length related to a minimum start-up temperature of +12°C, AC 230 V

	HWAT-L	HWAT-M	HWAT-R
10 A	80 m	50 m	50 m
13 A	110 m	65 m	65 m
16 A	140 m	80 m	80 m
20 A	180 m	100 m	100 m

7.3 Electrical loading

Over-current devices are selected according to the HWAT cable type, supply voltage, and circuit length to allow for start-up. The design specifies the size and type of over-current device. Pipe systems are often not installed as drawn in the installation plans. If changes are made, make sure that all circuit lengths comply with Table 4.

7.4 Ground-fault protection

Improper installation or mechanical damage to the heat-tracing cable can cause a ground fault or short. In the event of a ground fault, the fault current must be conducted to protective earth (PE) through the protective braid and the residual current device (rcd 30mA) so that the rcd can interrupt the circuit. It is therefore absolutely essential to connect the protective braid correctly in accordance with the installation instructions. This must be checked and approved by the installation technician.

⚠ CAUTION: In order to reduce risk, Chemelex recommendations for fault current circuit breakers (max. 30mA) must be installed as protection against ground faults.

⚠ CAUTION: Do not connect the HWAT cable and the components with the power on.

8 COMMISSIONING

Chemelex requires a series of commissioning tests be performed on the HWAT System. Individual tests are also recommended at regular intervals for preventive maintenance. Results must be recorded and maintained for the life of the system, utilizing the "Installation and Inspection Record" (refer to Section 11). Submit this manual with initial commissioning test results to the owner.

Ensure that your water heater and/or mixing valve temperature are set at your desired pipe maintain temperature.

Note: If the temperature exceeds 65°C in the HWATL/- M or 80°C in the HWAT-R, the heater life expectancy may be affected.

The following tests must be done after installing the RayClic connection kits, but before the thermal insulation is applied to the pipe:

1. Visual Inspection
2. Insulation resistance measurement

After the thermal insulation has been installed on the pipe, the following tests must be performed:

1. Visual Inspection
2. Insulation resistance measurement
3. Temperature check (hand test)

All test procedures are described in this manual. The installation technician is responsible for carrying out these tests. He may get an electrician to assist. Record the results in the Installation and Inspection Record in Section 11.

8.1 Visual inspection

- Check inside all power, splice and tee kits for proper installation, overheating, corrosion, moisture or loose connections.
- Check for damaged or wet thermal insulation. The pipe must be completely insulated and comply with local regulations.
- Check whether the identification labels are attached to the thermal insulation.
- Check HWAT-ECO control unit for proper setpoint and operation. Refer to the HWAT-ECO Installation and Operation Manual for details.

8.2 Insulation resistance measurement

Frequency

The insulation resistance measurement must be done during the building phase as follows:

- After installation of the component immediately before installing the thermal insulation
- Immediately after installing the thermal insulation

The values must be recorded. The measurements must be repeated after every maintenance and repair work.

Procedure

The insulation resistance measurement must be done (using an insulation tester with different test voltages) from 500 VDC to 2500 VDC. Potential problems may not be detected if testing is done only at 500 VDC and 1000 VDC. Measure the resistance between the bus wires of the heat-tracing cable and the protective braid (figure 10).

Note: System tests and regular maintenance procedures require that insulation resistance testing be performed.

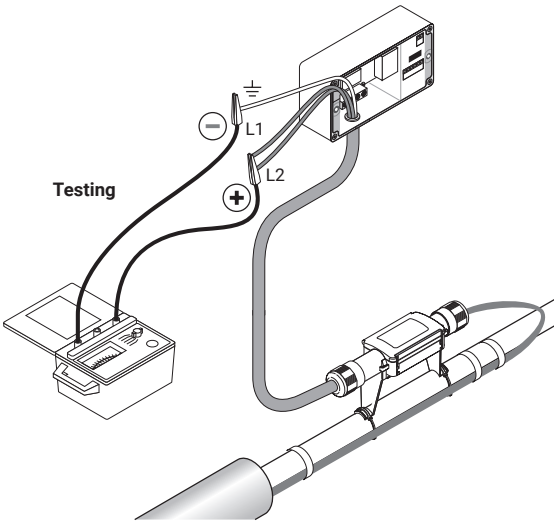

Figure 10: Insulation resistance test

Determining the insulation resistance

1. Make sure that the heat-tracing cable is voltage-free.
2. Disconnect the HWAT-ECO control unit from the heat-tracing cable if installed.
3. Switch off the insulation tester.
4. Connect the negative (-) lead to the heat-tracing cable metallic braid or RayClic yellow/green wire.
5. Connect the positive (+) lead to both heat-tracing cable bus wires or the RayClic brown and blue wires.
6. Switch on the insulation tester and set the voltage to the desired test voltage (500 VDC to 2500 VDC). The test time is 1 minute. Note the insulation resistance value in the commissioning report.
7. All insulation resistance values should be greater than 100 megohms. If the reading is lower, consult Section 9, Troubleshooting Guide.
8. If the insulation measuring device does not self-discharge, connect the metal braid and the two bus wires with each other.
9. Reconnect the heat-tracing cable.
10. Reconnect the HWAT-ECO control unit.

8.3 Temperature check (Hand Test)

Check whether each cable end is warm after 5 to 10 minutes during commissioning. Use an infrared thermometer, e.g. the Raychem CDE-IR-Temp if necessary. Cross connections between cold and hot water lead to malfunctions in the system. Make sure that the cold water and hot water is not in the same hydraulic pressure zone. Different flow pressures lead to strong temperature fluctuations at the outlet valve.

9 TROUBLESHOOTING

There are three methods used for finding a fault within a section of heat-tracing cable:

1. Determination of short circuit on self-regulating heat-tracing cable without simultaneous ground fault.
2. Determination of interruptions on self-regulating heat-tracing cables.
3. Determination of circuit lengths and interruptions in the heat-tracing cable (capacitance measuring method)

9.1 Determining the location of a short circuit on self-regulating heat-tracing cable without simultaneous ground fault.

This method uses resistance measurements taken at each end of the heat-tracing cable to exactly locate a short. Measure the resistance of the heat-tracing cable at both ends and note these values as "A" and "B".

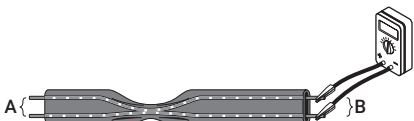

Figure 12: Resistance measurement

Calculation of fault location "D", expressed as a percentage of the heat-tracing cable length "A":

$$\text{Fault location: } D = \frac{A}{(A + B)} \times 100$$

Example: A = 1,2 ohms
B = 1,8 ohms

Fault location: $D = 1.2 / (1.2 + 1.8) \times 100 = 40\%$ The fault is at 40% of the circuit length measured from end "A".

9.2 Determining interruptions on self-regulating heat-tracing cables

Interruptions in the heat-tracing cables can be localised with this method. A damaged heat-tracing cable can lead to a cold pipe section.

Measure the resistances from bus wire to bus wire at both ends in the section in which the fault is suspected and note these down as values "A" and "B".



Figure 13: Measurement of the HWAT cable resistance

Calculation of fault location "D", expressed as a percentage of the heat-tracing cable length:

$$\text{Fault location: } D = \frac{1/A}{(1/A + 1/B)} \times 100$$

Example: A = 100 ohms
B = 25 ohms

Fault location: $D = (1/100) / (1/100 + 1/25) \times 100 = 20\%$

The fault is at 20% of the circuit length from end "A" of the heating circuit.

9.3 Determining circuit lengths and interruptions in the heat-tracing cable (capacitance measuring method)

Note: The capacitance test can only be applied to unbranched heating circuits.

1. Connect the capacitance meter negative lead to both bus wires and the positive lead to the protective braid of the heat-tracing cable. Set the meter to the 200nF range.
2. The capacitance must be measured between both bus wires twisted together (positive lead) and the braid (negative lead). Note down the value.



Figure 11: Capacitance test

3. Select the capacitance factor for the installed heat-tracing cable from table 4.

Table 4: Capacitance factors

HWAT heat-tracing cable

Capacitance Factor	m/nF
HWAT-L	1.65 m/nF
HWAT-M	1.65 m/nF
HWAT-R	1.62 m/nF

4. Calculate the circuit length or the fault location as follows:

$$\text{Length (m)} = \frac{\text{Capacitance (nF)}}{\text{Capacitance factor (m/nf)}}$$

Example for HWAT-R:

Measured value C = 42.2 nF

Capacitance factor X = 1.62 m/nF

Fault location = 42.2 nF x 1.62 m/nF = 68.4 m from the measuring location

As an alternative, capacitance values can be measured at both ends. The ratio of one capacitance value measured at one end (A) divided by the sum of both A and B (A + B) and then multiplied by 100 yields the distance from the end "A", expressed as a percentage of the total heat-tracing cable circuit length. See Table 4 for capacitance factors.

$$\text{Fault location: } C = \frac{A}{(A + B)} \times 100$$

10 LIST OF POSSIBLE FAULTS

Symptom	Probable causes
Water temperature too low	Insulation is wet, incorrectly sized, or missing.
	The HWAT-ECO control unit lowered the pipe maintain temperature because water heater is cold.
	Ambient temperature too low.
	Insulation not thick enough.
	HWAT-ECO was set incorrectly.
	Cold water is being introduced into the hot water system.
	Boiler temperature too low Used heat-tracing cable deviates from the programmed heattracing cable.
Symptom	Probable causes
Low or no power output	Low or no input voltage applied
	Heat-tracing cable not installed along the whole pipe length or interruption in the heating circuit
	Connection kit or RayClic not connected properly
	HWAT-ECO setting or connection incorrect.
	The heating cable has been exposed to excessive temperature, moisture or chemicals
	Heating cable with too low a power installed

Corrective action

Remove the wet insulation and replace with dry. Give this a suitable weatherproof protection.

Check the setting of the HWAT-ECO boiler sequence, the temperature of the water heater and the position of the sensor. Make corrections where necessary.

Set the correct ambient temperature in the Setup menu on the HWAT-ECO.

Adapt the insulation thickness according to the table in the Technical Manual.

Refer to the HWAT-ECO Installation and Operation Manual for the correct settings.

Verify that the plumbing fixtures and valves are operating properly.

Check the boiler temperature and reset the time program HWAT-ECO to the factory setting, repeat quick start-up and select the installed heattracing cable.

Corrective action

Repair the electrical supply lines and equipment.

Check the routing and length of heat-tracing cable (use "as built" drawings for actual pipe layout). Connect all splices or tees. Locate and replace any damaged heat-tracing cables.

Examine RayClic connection kits for proper installation. Check for loose wiring connections and rewire where necessary.

See the HWAT-ECO Installation and Operation Manual for the correct settings or connect the HWAT-ECO according to the connection plan.

Check the pipe or boiler temperature. Compare the heating power of the HWAT cable according to the layout with the actual heating power. Reduce the pipe temperature if possible or consult your Chemelex representative to have the layout confirmed.

Replace damaged heat-tracing cable. Check the pipe temperature.

Replace heating cable if necessary.

Symptom	Probable causes
Circuit breaker (CB) or residual current device (rcd) trips	Circuit breaker is undersized or the tripping characteristic is not type "C"
	Short in the connection kit
	Heat-tracing cable damaged
	Wire of the heat-tracing cable shorted at the circuit end
	Permissible circuit length exceeded
	Cuts and/or abrasions exists in heat-tracing cable or power feed wire with moisture present or moisture in connections.
Residual current device (rcd) undersized (5 mA instead of 30 mA) or incorrectly wired	

Symptom	Probable causes
Low or inconsistent insulation resistance	Mechanical damage to protective jacket of heat-tracing cable or damaged insulation of the heating element
	Moisture is present in the connection kits.

Corrective action

Recheck the design for startup temperature and current loads. Do not exceed the maximum circuit length for HWAT cable used. Replace the circuit breaker, if defective or improperly sized.

Visually inspect the RayClic connection systems. Replace if necessary.

Check for damage around the valves and any area where there may have been maintenance work. Change damaged sections.

Check the end seals to ensure that bus wires are not shorted. If a short is found, the HWAT cable may have been permanently damaged by excessive current and may need to be replaced.

Separate the circuit into multiple circuits that do not exceed max circuit lengths.

Replace the heat-tracing cable, as necessary. Dry out and reseal the connection and splices. Check the insulation resistance with an insulation tester.

Install residual current device (rcd) 30 mA or check wiring of rcd.

Corrective action

If pipe with heat-tracing cable is not yet insulated, visually inspect the entire circuit length for damage, especially at elbows and flanges and around valves. If the system is already fitted with thermal insulation, the heating circuit can be disconnected at the connection kits to localise the fault. Repeat the insulation test every time.

Check RayClic for damage. Tighten cable gland. Check seal in lid of RayClic and then re-close (the catch must close audibly and visibly). If water has penetrated the Rayclic system, the heat-tracing cable may have been damaged. The heat-tracing cable must then be replaced.

11 COMMISSIONING REPORT

Chemelex – Hot Water Temperature Maintenance Systems

Commissioning Report

Facility:

Inspection date:

Heating circuit number:

Heat-tracing cable (type):

Raychem HWAT-ECO setting:

Water heater/mixing valve setting:

Circuit length:

Commissioning

Inspection date:

Visual Inspection

Testing of the residual current device (rcd) (30 mA)

(nominal value/function correct)

Visual inspection of connection kits to determine overheating, corrosion, moisture, loose connections and other problems.

Correct electrical connections, thermal insulation damaged or missing.

Identification labels attached correctly to the insulation.

Check the Raychem HWAT-ECO for moisture, corrosion, set values and correct connection

Insulation resistance test

M-Ohms

Measurement between heating element	500 VDC
wire and protective braid for test voltage:	1000 VDC
(test A)	2500 VDC

Power test

Operating voltage

Heating circuit current after 2 hours (A)

Pipe temperature (°C)

Power = (volts x amps after 2 hrs) / circuit length
(watts/m)

België / Belgique

Tel +32 16 21 35 02
Fax +32 16 21 36 04
SalesBelux@chemelex.com

Bulgaria

Tel +359 2 973 33 73
SalesEE@chemelex.com

Česká Republika

Tel +420 606 069 618 (Comm)
+420 602 232 969 (Ind)
infoCZ@chemelex.com

Danmark

Tel +45 70 11 04 00
SalesDK@chemelex.com

Deutschland

Tel 0800 181 82 05
SalesDE@chemelex.com

España

Tel +34 911 59 30 60
Fax +34 900 98 32 64
SalesES@chemelex.com

France

Tél 0800 90 60 45
SalesFR@chemelex.com

Hrvatska

Tel +385 51 225 073 (Comm)
+385 1 605 01 88 (Ind)
SalesEE@chemelex.com

Italia

Tel +39 02 577 61 51
Fax +39 02 577 61 55/28
SalesIT@chemelex.com

Lietuva/Latvija/Eesti

Tel +370 698 411 56
SalesEE@chemelex.com

Magyarország

Tel +36 1 253 76 17
SalesHU@chemelex.com

Nederland

Tel 0800 022 49 78
SalesNL@chemelex.com

Norge

Tel +47 66 81 79 90
SalesNO@chemelex.com

Österreich

Tel 0800 29 74 10
SalesAT@chemelex.com

Polska

Tel +48 22 331 29 50
Fax +48 22 331 29 51
SalesPL@chemelex.com

Қазақстан

Tel +7 7112 31 67 03170
SalesKZ@chemelex.com

Serbia and Montenegro

Tel +386 41 665 634 (Comm)
+381 230 439 519 (Ind)
SalesEE@chemelex.com

Schweiz / Suisse

Tel +41 (41) 766 30 80
Fax +41 (41) 766 30 81
infoCH@chemelex.com

Suomi

Puh 0800 11 67 99
SalesFI@chemelex.com

Sverige

Tel +46 31 335 58 00
SalesSE@chemelex.com

Türkiye

Tel +90 545 284 09 05
SalesEE@chemelex.com

UK/Ireland

Tel 0800 969 013
SalesUK@chemelex.com

chemelex
excellence is everything

chemelex.com

Raychem Tracer Pyrotenax Nuheat

©2025 CHEMELEX. All CHEMELEX marks and logos are owned or licensed by CHEMELEX Europe GmbH or its affiliates. All other trademarks are the property of their respective owners. CHEMELEX reserves the right to change specifications without notice.

RAYCHEM-IM-INST293-HWATsystem-EN-2504