

Slotted Conduit, Pull Box & Pull Rope

Installation Instructions

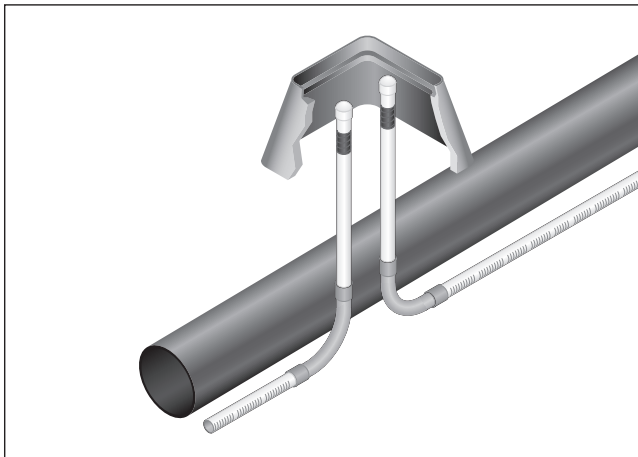

KIT CONTENTS

Item	Part #	Description
A	Raychem TraceTek TT-PVC-Solid-1 ½	Solid wall PVC- 3 meter length, no threads
B	Raychem TraceTek TT-PVC-Slot-1 ½	Slotted PVC-3 meter length, threaded
C	Raychem TraceTek TT-Riser Kit-1 ½	Cable rack/air lock
D	Raychem TraceTek TT-PR	Pull rope
E	Raychem TraceTek TT-PVC-Slip Fit	PVC slip fit couplings for risers
F	Raychem TraceTek TT-PVC-1½-Cap	PVC cap
G	Raychem TraceTek TT-PVC-Sweep 90-1 ½ PVC large	90 degree radius sweep
H	Raychem TT-Pull Box	Grade level pull box

DESCRIPTION

These instructions are intended to guide the contractor through the process of installing the conduit, pull rope and pull boxes that are an essential part of the Raychem TraceTek pipeline leak detection system. The conduit and pull boxes are usually installed during the initial phase of the project when the trench has been opened and the pipeline is being laid.

TOOLS & MATERIALS REQUIRED

- Sizing tool
- Razor knife
- Hack saw
- Two different colors of electrical tape
- PVC pipe cutter
- PVC adhesive
- Fish tape

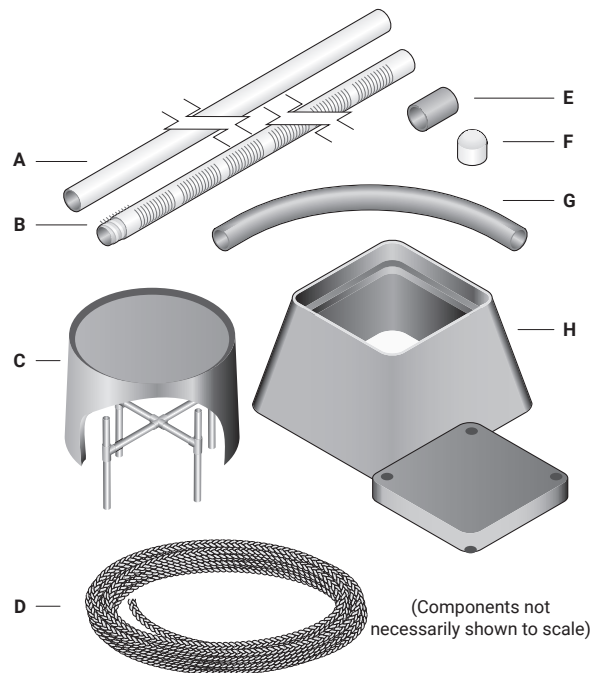

⚠ IMPORTANT:

- Keep the conduit system straight and clean. Avoid unnecessary direction changes, and don't allow extra conduit to form "S" curves along the trench floor. Make sure the conduit is on one side of the pipe.
- Fix any problems that prevent the pull rope and sizing tool from moving freely before the cable installation begins.
- Use end caps. Slip the caps onto the conduit every time the conduit is left unattended, for example during lunch breaks, overnight or while waiting for materials or other delays.
- Any section of conduit that will not allow the sizing tool to pull from one pull box to the next is not ready for sensor cable installation. Do not try to force it. Identify the source of any clearance problems and make the necessary repairs before the cable installation begins.

Assembly Techniques

Conduit issues

- Keep the conduit system straight and clean, avoid unnecessary direction changes. Don't allow extra conduit to form "S" curves along the trench floor.
- Keep conduit on one side of pipe.
- Use end caps!
- Slip the caps onto the conduit every time the conduit is left unattended.
- Prevent rocks or heavy objects from falling onto the conduit.
- Repair any breaks with a clean cut, slip fittings and new rope if necessary.
- All of the conduit and rope components are inexpensive and easy to replace, but problems that are not corrected at this early stage are very expensive to repair later.

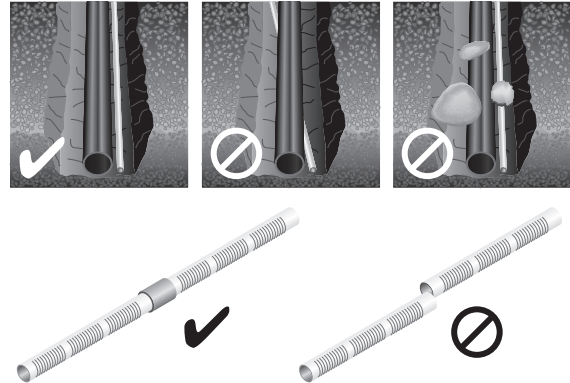

Pull rope issues

- Pull rope is inexpensive, so don't try to save money by knotting or splicing.
- Each length should be continuous from one pull box to the next.
- Pull rope is supplied on large reels, so be sure there is someone at the reel to help pull the rope off of the reel and feed it into the conduit.
- Don't try a one-person pull through the conduit from 100 meters away.
- Excessive force when pulling the cable will cut into and damage the PVC conduit.
- The rope should pull easily with one hand.

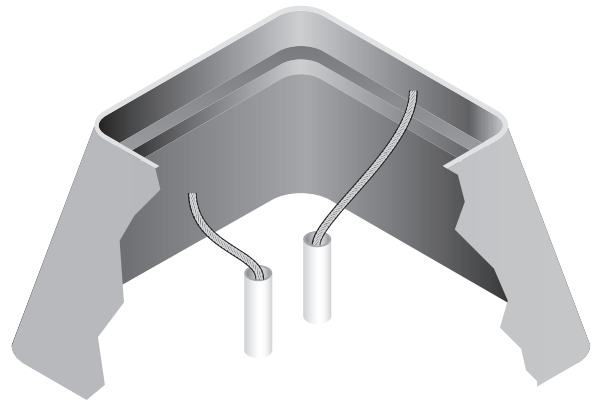

Pull rope techniques

- The contractor must provide "jack stands" and an axle to support the reel and act as a payoff.
- Don't place the reel on the ground because it may pick up dirt, rocks or mud that can get pulled into the conduit.
- Each bend or change of direction multiplies the pulling force on the rope. By "helping" the cable into the first bend, you can keep the initial resistance close to zero and that greatly reduces the accumulated drag.

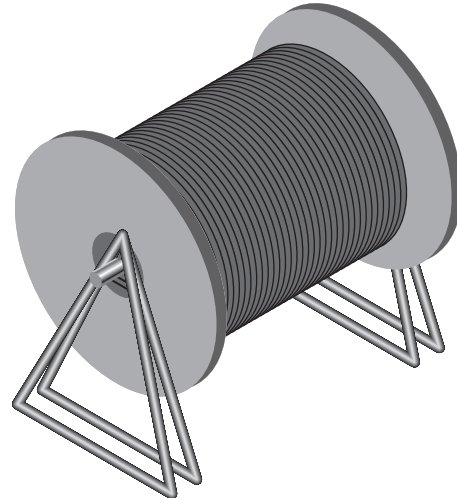

PVC issues

- Most of the slotted PVC connections are threaded joints. There is no need for adhesive or excess force. Simply twist the new section a few turns to add to the total conduit length 3 meters at a time.
- The vertical risers and 90° bends are not threaded and they are joined using slip fittings and PVC adhesive. Standard PVC adhesive is used for all slip fittings. Use enough adhesive to make a good joint but do not use an excessive amount. If the adhesive drips into the interior of the conduit, use less adhesive.
- All of the conduit and bends are made with 1 ½ inch diameter, Schedule 80 (thick wall) PVC. It is very rugged, but PVC is plastic and it can be crushed or broken with sharp impacts or excess force.
- Caution: At very low temperatures (below freezing) PVC becomes more brittle and excessive bending can cause it to break.
- In long lengths, the conduit is flexible enough to work above the pipe trench and then be lowered into place without damage.
- Be careful with rocks, tools, materials or debris along the side of the trench. Dropping large rocks or tools onto the conduit can damage the conduit and necessitate repairs.

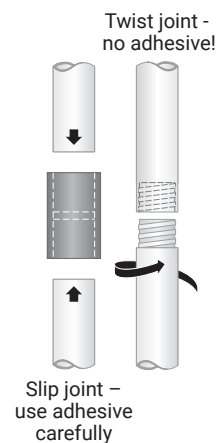

Making an eye-splice with hollow braid rope

- Pull rope is used for pulling sensor cable, jumper cable, sizing tools and cleaning rags through the completed conduit system. The best way to attach various cable or tools to the rope is with an "eye-splice". The following steps illustrate how to form the splice.

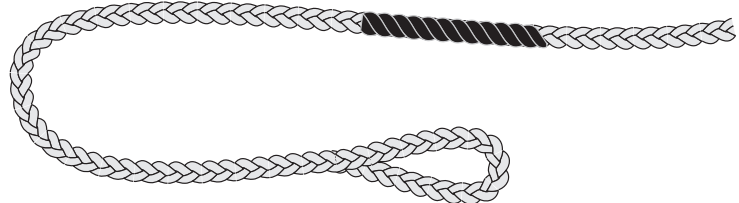

1

- Cut the rope end at a 45° angle.

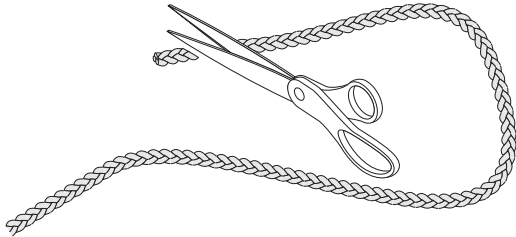

2

- Wrap the end with electrician's tape to make a sharp point.

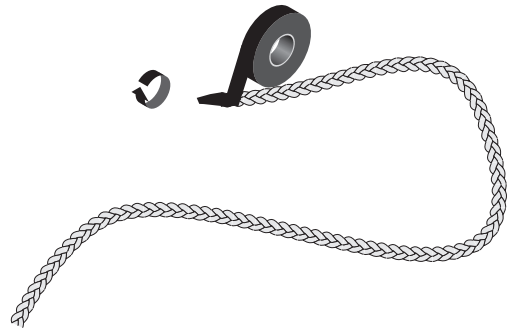

3

- Make a loop with about 50 cm of rope. (in this photo we are attaching a sizing tool)



4

- Feed the taped end of the rope into the hollow core of the rope just below the sizing tool.

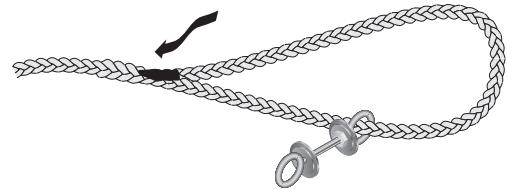

5

- Work the end of the rope into the hollow core of the rope until almost all of the 50 cm is inserted.

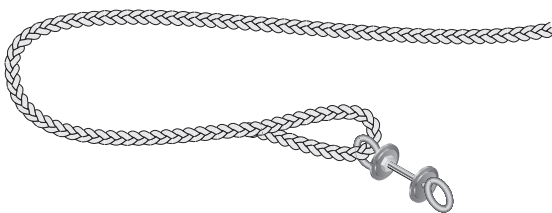

6

- Add an extra few wraps of tape at the base of the splice for extra security.



PVC & Pull Rope Installation Instructions

Conduit and pull rope installation sequence

- Prepare several vertical risers with 90° bends and slip fit connectors, use sufficient but not too much PVC adhesive and set them aside to dry.
- It is a good practice to pre-fabricate several of these vertical assemblies and set them aside until they are needed.
- Every pull box location will require two riser assemblies except for the first and last ones in the system.

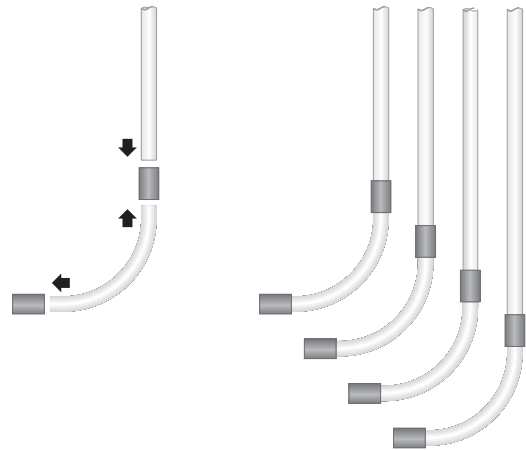

1

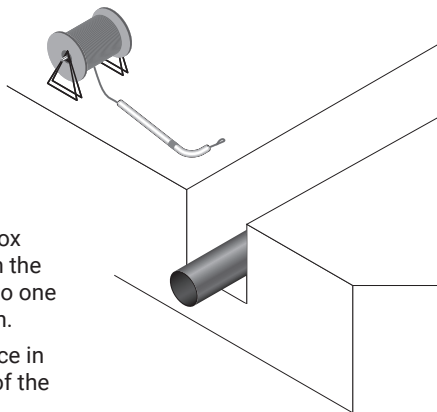

- At the first pull box location, position the reel of pull rope to one side of the trench.
- Form an eye-splice in the leading end of the pull rope.
- Use a stiff piece of wire or a "fish tape" to thread the pull rope into one of the vertical riser assemblies from the top down and through the 90° bend.

2

- To join the first 3 meter length of slotted PVC conduit use the PVC cutter or a hack-saw to cut off the female thread end portion (about 5 cm).

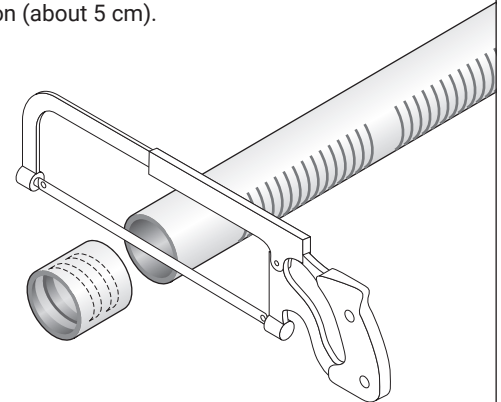

3

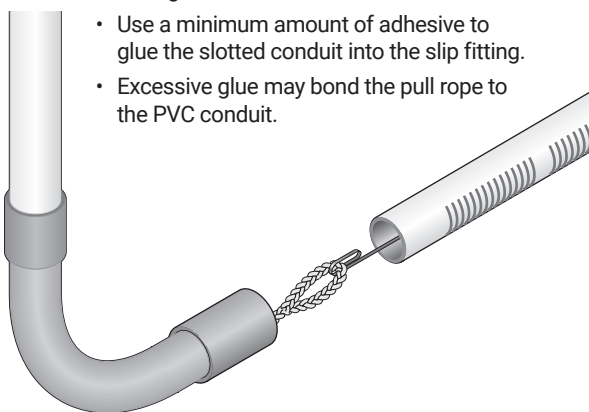

- Use a stiff wire or "fish tape" to pull the rope through the first section of slotted conduit.
- Use a minimum amount of adhesive to glue the slotted conduit into the slip fitting.
- Excessive glue may bond the pull rope to the PVC conduit.

4

- Assemble the horizontal portion of the conduit system, threading additional rope through each incremental 3 m section of slotted conduit. Do not use any glue or adhesive on the threaded couplings. Twist them together by hand.

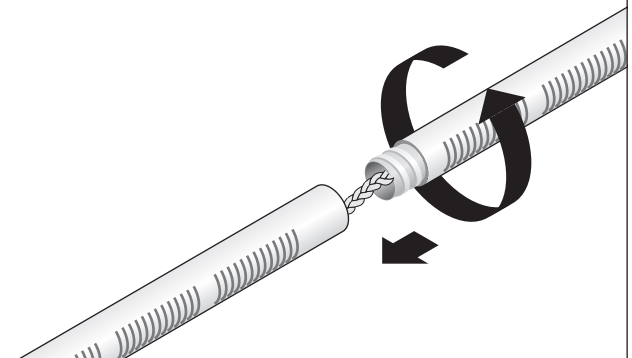

5

- The entire process of conduit assembly can be started and continued while working at grade level on one side of the trench.
- After the steel pipeline has been positioned on the bottom of the trench, it is time to lower the PVC conduit onto the same bedding sand.
- The long run of conduit will be flexible enough to gradually move the conduit onto the trench floor without dropping or breaking.

6

- After a maximum of 200 m of slotted conduit is installed, use a hacksaw or conduit cutter to trim the last length of slotted conduit to adjust to the next pull box location.

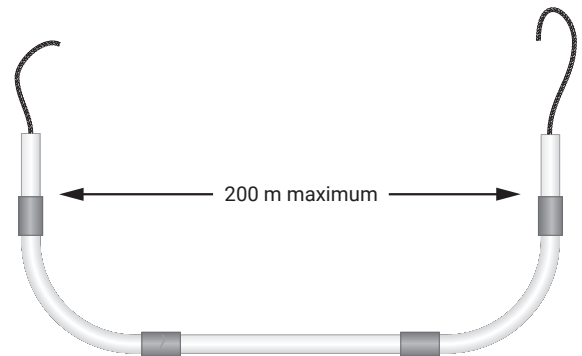

7

- Thread the pull rope through the riser assembly, then use a minimum amount of adhesive to glue the vertical riser assembly to the end of the slotted conduit. Be careful with the PVC adhesive so the rope is not glued by accident.

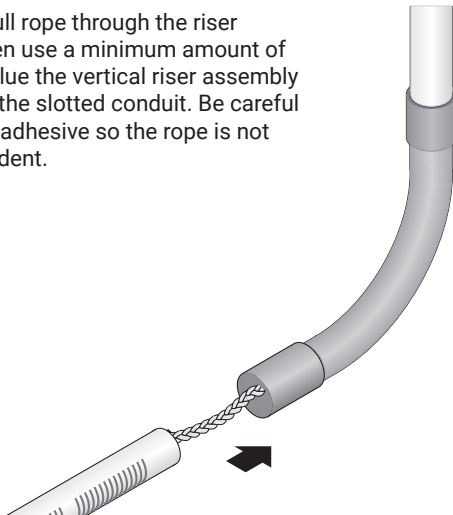

8

- Make a test to make sure that the pull rope moves freely without binding or excess force. If there is any doubt investigate and fix the problem now.

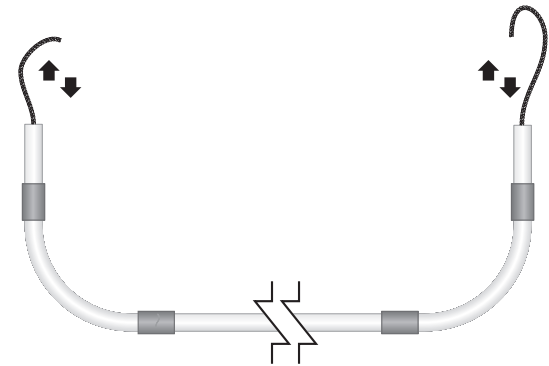

9

- If the rope checks out OK, then cut the rope, bundle the extra 2 meters of rope at each end and push into the end of each riser, then install end caps without any glue.
- If the conduit is not already lowered onto the trench floor, now is a good time to do it.

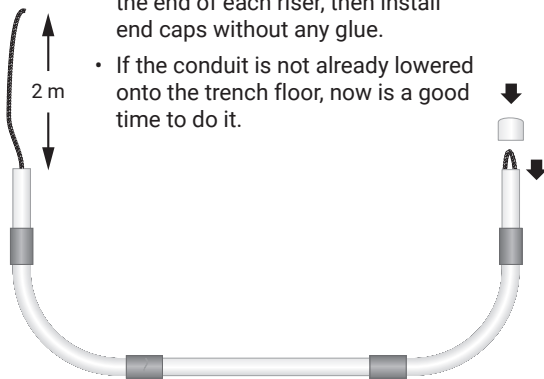

10

- Prepare for backfilling.
- Identify the separate risers by using colored tape to mark the "Northbound" and "Southbound" conduits.
- Blue is northbound and red is southbound. After the conduit is buried it will not be obvious which direction either pull rope will run, so consistent identification on the end of the riser is necessary.

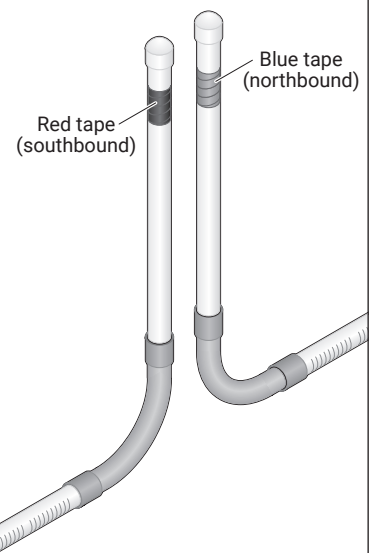

During backfill, the backfill material can push the PVC conduit risers out of position. Movement can be significant enough that the risers no longer fit within the footprint of the pull box which must be installed over the risers after backfill. Therefore, it is recommended that some sort of physical bracing be attached to the PVC conduit risers in order to maintain their spacing and their positioning within the trench. Any bracing which limits the PVC conduit movement during backfill can be used. The following Steps 11 – 13 provide one method of accomplishing this bracing using scrap wood commonly available on the job site.

11

- Slip two-hole wooden spacers over the two risers to keep risers separated at pull boxes. The two risers should be 280 mm \pm 50 mm (11 in \pm 2 in) apart center to center. If they are too close together it will be difficult to cut the risers to their proper length; if they are too far apart, they will not fit under the air lock cover.

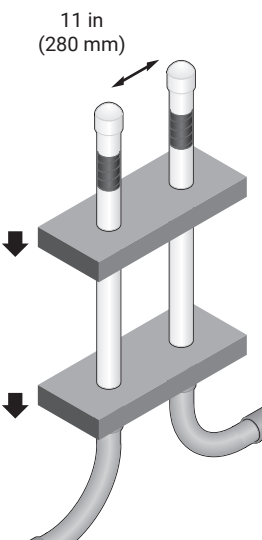

12

- Hold spacers in place with tie wraps or electrician's tape. A short piece of conduit with a 45° notch cut in each end is a good alternative if the wooden spacers are not available.

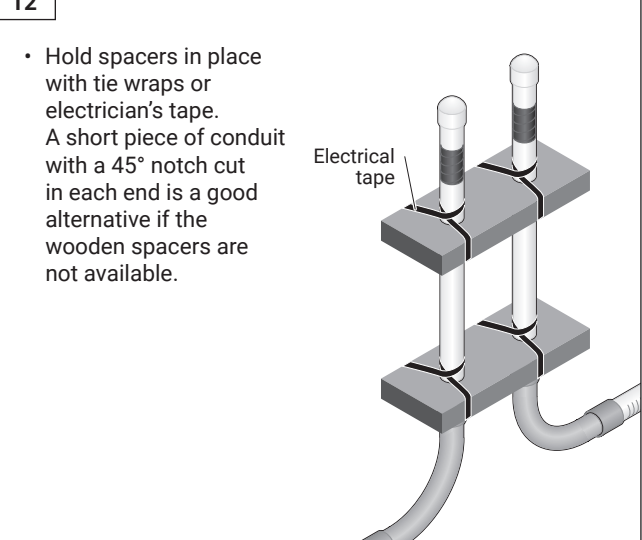

13

- Place a long piece of wood across the trench and use this wood as a brace to hold the two risers in vertical position at the start of the back fill process.

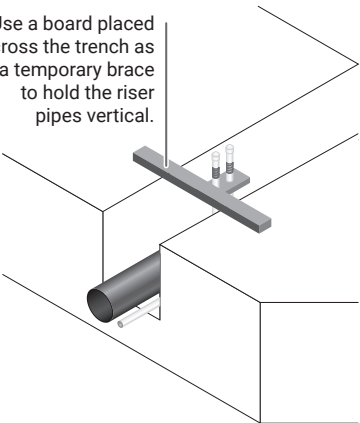

Pull Box & Riser Kit Instructions

1

- After the risers are braced in the vertical position, they will likely extend above the finished grade.

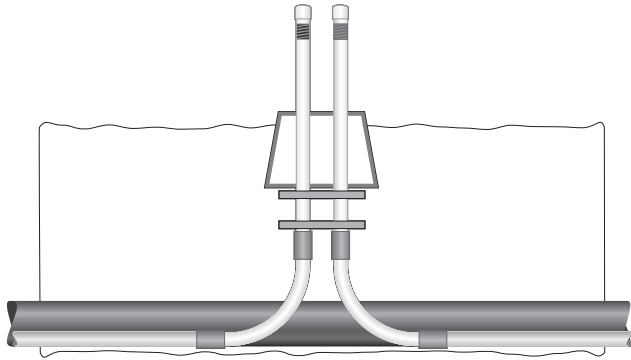

2

- The risers will not be directly over the pipeline but will be to one side of the trench directly above the path of the slotted conduit.
- Heavy equipment can be used for the backfill except in the area around the pull-boxes.
- Use hand tools to widen the area around the riser and partially fill towards grade level.

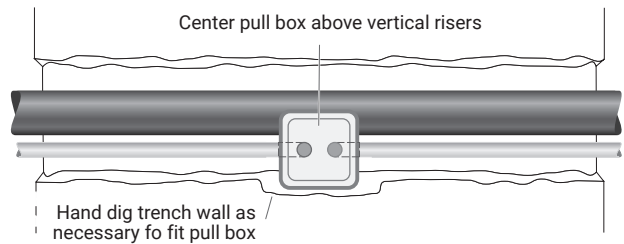

3

- Add about 10 cm of fill inside of box to adjust "floor height" for the cable support stand and air lock bucket.
- Compact the soil in and around the pull box as much as possible.

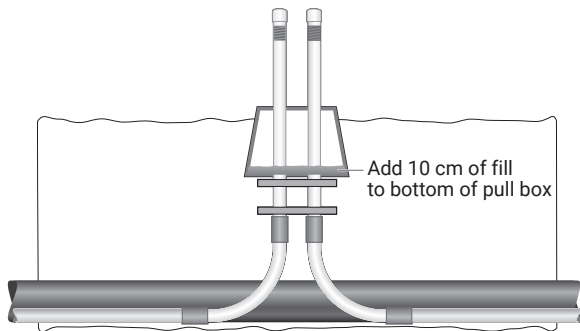

4

- Without cutting the pull rope, carefully cut the vertical risers so that they stick out of the "floor" fill by 230 mm ± 50 mm (9 in ± 2 in).
- It may be easier to push the rope further down into the riser during the cutting operation.
- Use more of the red and blue tape to clearly indicate which riser is headed north and which riser is headed south.
- Make sure the pull rope ends can be reached, replace the end caps to keep out dirt and rocks.

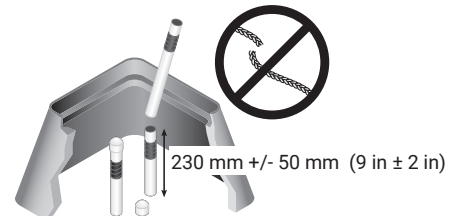

5

- Assemble the riser kit cable support stand, place it over risers, place the air-lock (upside down, blue bucket) over the cable stand and the capped off riser ends.

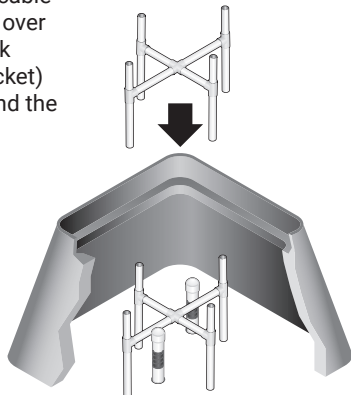

6

- Position the pull box cover and bolt it into place.

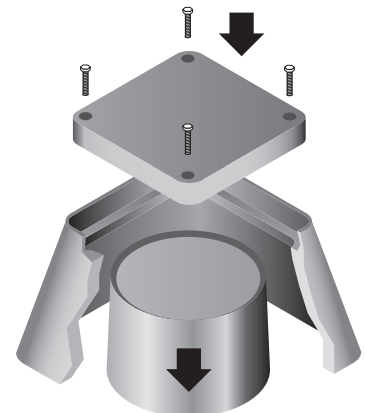

Proof the Pipe

1

- Clean and verify each section after backfilling by using a rag and the sizing tool for a final cleaning and to check for clearance.
- Use an eye-splice to connect a coil of rope (10 m longer than the longest anticipated pull) to one end of the sizing tool.
- Use an eye-splice to connect the other end of the sizing tool to one end of the pull rope already installed in a section of conduit.
- Tie a piece of towel or rag through the eye splice in advance of the tool.
- Now pull the sizing tool from one end of the conduit section to the other.

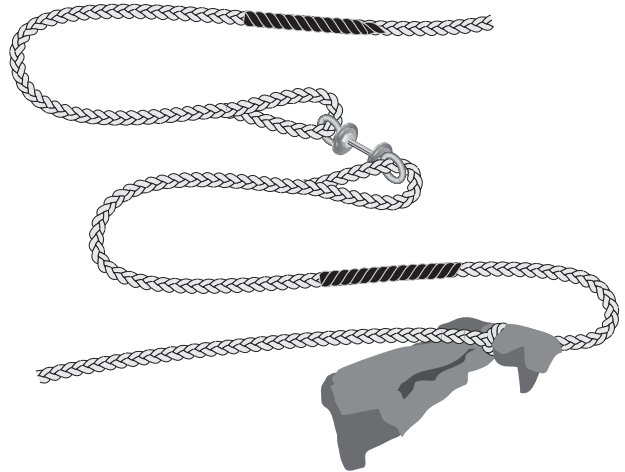

2

- As you pull, coil the pull rope by hand to keep it out of the dirt.
- After pulling the tool through the entire length of conduit, replace the rag with clean material if necessary, move the rag to other end of the pulling tool and reverse the process to pull the original pull rope back into the conduit.
- The idea is to make sure that the conduit is free from any accumulated dirt or mud and to make sure that there are no crushed or broken sections of conduit.



3

Inspector Check List

1. Verify that the sizing tool pulls freely through each section of conduit.
2. Verify that the pull rope is free of knots and splices and that there is 2 m of extra rope at both ends of each section.
3. Verify trimmed height of riser tubes above back fill is 230 mm \pm 50 mm (9 in \pm 2 in).
4. Verify spacing of riser tubes is 280 mm \pm 50 mm (11 in \pm 2 in) mm center to center.
5. Verify conduits are marked with different color tape to indicate directions.
6. Verify end caps are used to cover the extra pull rope and riser when the inspection is completed.

North America

Tel +1 800 545 6258
info@chemelex.com

Latin America

Tel +1 713 868 4800
info@chemelex.com

Europe, Middle East, Africa, India

Tel +32 16 213 511
Fax +32 16 213 604
info@chemelex.com

Asia Pacific

Tel +86 21 2412 1688
infoAPAC@chemelex.com

chemelex
excellence is everything

Raychem

Tracer

Pyrotenax

Nuheat