

Raychem

TT1100-OHP-THIN

Water Sensing Cable for Insulated Pipe Installation Instructions

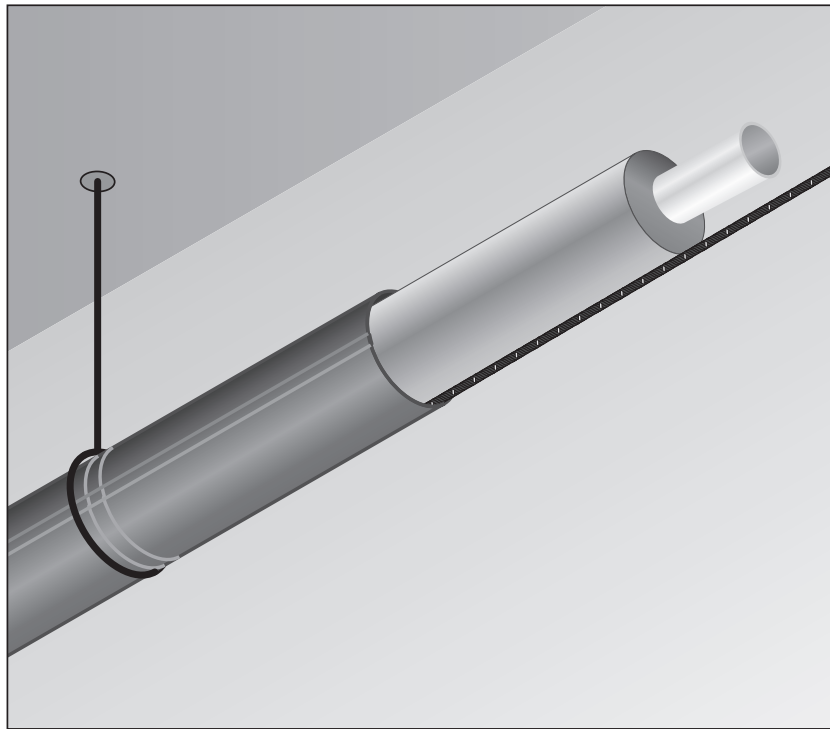

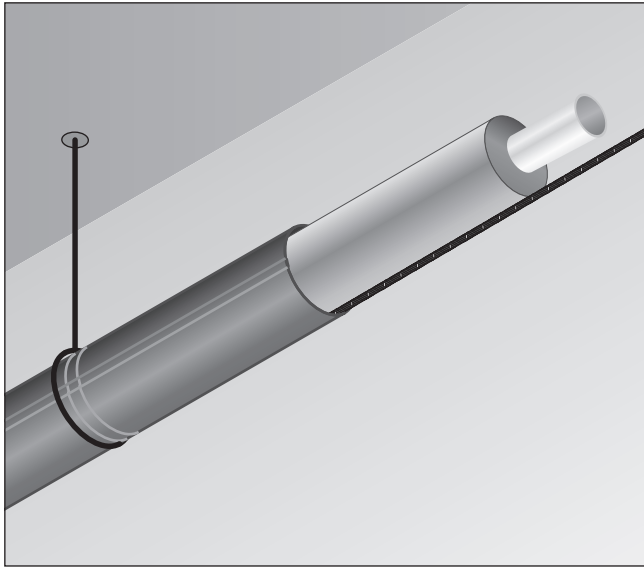

DESCRIPTION

These Instructions explain the proper procedures for installing and testing Raychem TraceTek TT1100-OHP-THIN sensing cables. TT1100-OHP-THIN sensing cables are primarily intended for use on overhead insulated pipe to detect a water leak originating from a small pin hole or crack in the pipe. TT1100-OHP-THIN should be positioned along the bottom of the insulation, held in place with thin tape and then secured by and within the sheet metal lagging.

Important Notes

When used to monitor suspended or rack mounted pipe, TT1100-OHP-THIN sensing cables must be attached to the pipe at the lowest point where any water leak is most likely to drip from the pipe system. This will be the 6 o'clock position on horizontal piping but other mounting locations and techniques may be necessary if site conditions are unusual. In particular, special consideration should be given to pipe supports, couplings, "T's", valves and other fittings. It is the responsibility of the installer to position the cable such that any leak will saturate the area of insulation in contact with the sensing cable.

The sensing cable cannot stop a leak. In some installations the materials or structures beneath the pipe system may be so critical or valuable, that a drip tray system should be considered in addition to the sensing cable installation. TT1100-OHP-THIN is intended to alert the user that a pipe or system is leaking but it cannot prevent collateral damage if the leak is not contained and repaired immediately.

OPTIONAL MATERIALS

- | | |
|---|--|
| • TT-MBC-PC (PN 847529-000) | Branch connector used to connect and branch "T" lines. |
| • TT-MJC-xx-PC | This jumper cable is available in various pre-cut and terminated lengths. |
| • TT-1100-OHP-CK-PC-M/F (PN P000001186) | Connector kit used during field connections of TT1100-OHP-THIN bulk cable. |

TOOLS REQUIRED

- | | |
|-------------------------------------|--|
| • TT-PTB-1000 (PN 486437-000) | Portable Test Box, battery powered instrument designed for testing and troubleshooting TraceTek systems. |
| • Digital multimeter | Can be used as an alternative or supplement to the PTB. Meter must have 20 MΩ range. |
| • TT-MAPPING CAP-PC (PN P000000872) | Used to simulate leaks at connector points during commissioning and mapping process. |
| • Extra TT-MLC-PC (PN 683262-000) | Leader cable. Used with the ohmmeter to make easier connections to the sensing cable for resistance measurements. |
| • Extra TT-MET-PC (PN 169905-000) | End termination. Used during installation or trouble shooting to temporarily isolate a sub-section of sensing cable for resistance measurements. |

⚠ GENERAL NOTES: DO'S AND DON'TS:

DO:

- Store the cable in its original container in a clean, dry area until ready to install.
- Clean the pipe surface where the cable will be installed.
- Schedule the sensing cable installation as late as possible in the construction schedule to avoid risk of damage or contamination by other contractors or construction tasks.
- Remove cable from the pipe if any thread cutting, welding, soldering or similar pipe fitting work will be performed.

DON'T:

- Drag the cable through water, paint, solvents, oil or other contaminants.
- Install damaged or contaminated sensing cable.
- Allow the cable to become wet or contaminated after installation.
- Use the cable as a rope for lifting or securing any object.
- Allow tools or heavy objects to fall on cable.
- Exceed 3300 ft (1000 m) sensing cable circuit length

INSTALLATION

1

Prepare the insulated pipe where the cable will be installed.

Verify that major construction is complete:

- Verify that insulation around the pipe is completely installed and is dry.

2

Check each length of sensing cable before installation.

- To ensure that each length of sensing cable is intact and free of contamination, follow the Sensing Cable Test Procedure. Do not use damaged or contaminated sensing cable.

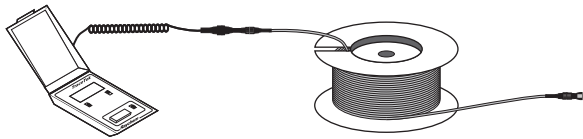

3

Observe proper precautions when handling sensing cables.

- Observe the do's and don'ts under "General Notes" on page 1 of these instructions; take care to avoid damaging or contaminating sensing cable.



Connect, orient, install, and test each length of sensing cable in sequence

1. **Connect** a Modular End Termination (TT-MET-PC) to the first sensing-cable length to be installed.
2. **Orient** sensing cable so the connector used with the end termination will be the furthest away from connection to the TraceTek alarm module. Start from the alarm module connection. For sensing cable on reels (lengths over 10 feet (3 m)), put the reel on an axle and pull the cable out.
3. **Install** sensing cable in accordance with the leak detection layout plan.

For horizontal pipeline applications (after pipe and insulation are in place):

 - Position and secure the cable along the bottom of the insulated pipe at the 6 o'clock position. If necessary, the cable can be **temporarily** secured using thin tape. Tape must be removed before sheet metal lagging is installed. Failure to remove tape can compromise system performance.



Important: It is the installer's responsibility to position the sensing cable correctly. The cable should trace the lowest point of the pipe or fittings such that any water leaking from the pipe or fittings will saturate the area of insulation in contact with the sensing cable. Do not install the cable on the top or side surface of a pipe. Do not spiral the cable on horizontal pipe.

Exception: If the cable is used to trace vertical pipe, the cable should be spiraled around the pipe. If necessary, the cable can be **temporarily** secured using thin tape. Tape must be removed before sheet metal lagging is installed. Failure to remove tape can compromise system performance.

4. **Install** sheet metal lagging around insulated pipe and sensing cable – Maintain the cable position near 6 o'clock position. If tape was used to secure cable position, remove the tape before installing the sheet metal lagging. When applying sheet metal lagging over the insulation and TT1100-OHP-THIN sensing cable, take care to avoid any sharp metal edges coming into contact with the sensing cable.
5. **Test** each length of sensing cable after installing it and before attaching it to cable already installed. Confirm that the sensing cable is clean and intact by following the Sensing Cable Test Procedure.
6. **Connect** the sensing cable to the cable string (lengths of sensing cable connected in series) previously installed.
 - **Note:** As an extra precaution on large installations, periodically test the entire cable string to confirm that all installed sensing cable is still clean and intact.
 - Unplug the end termination and connect it to the next length of sensing cable to be installed.
7. **Repeat** the installation sequence for each length of cable.

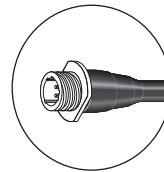
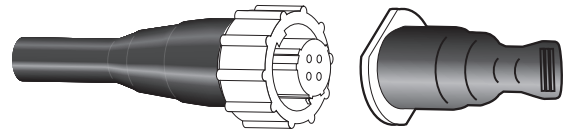

Cable connector with pins toward alarm module

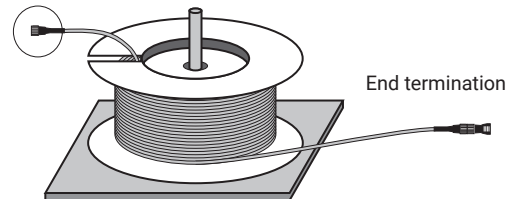

End termination

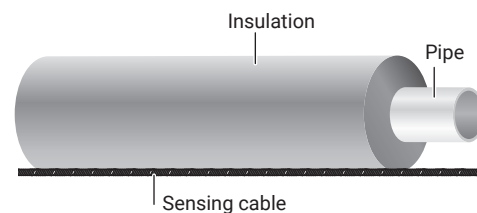

Horizontal pipe

Note: Shown without sheet metal lagging

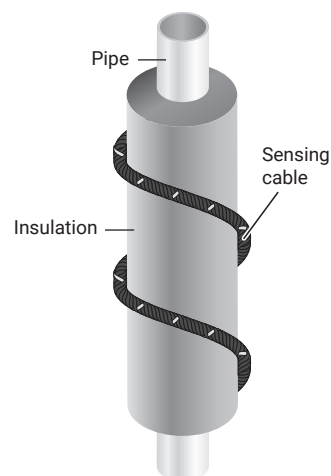

Vertical pipe

Note: Shown without sheet metal lagging

Complete the system

1. Install other TraceTek components (such as Modular Branching Connectors, Weighted Lengths, and Modular Jumper Cables) as called for in the system layout. Complete the sensing circuit.



Note: All components of the system have male or female plastic connectors or both. The male connectors are oriented toward the instrument panel. As new sections of cable are added to the main leg or branch, each newly added section ends with a female connector. To complete the circuit the end of each branch or main leg is terminated with a male end termination.

2. Test the sensing circuit (or portions of it) to confirm that the sensing cable is clean and intact. Follow the Sensing Cable Test Procedure.
3. Connect the sensing circuit to the TraceTek alarm module and activate the system as soon as is practical. Use the alarm module to monitor the sensing cable during the final stages of construction.

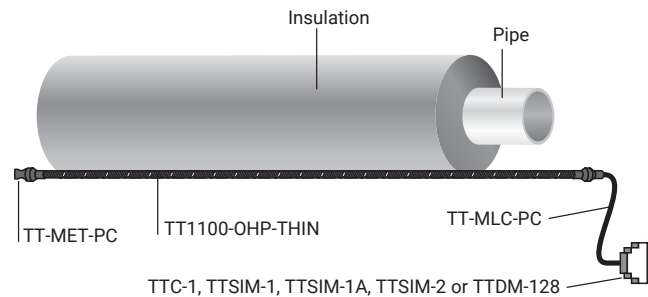

Note: Pipe and insulation shown without sheet metal lagging

Take precautions if installation is incomplete at the end of the work day.

At the end of the work day:

- Ensure that there are no open connectors. Each sensing cable should be connected to a Raychem TraceTek Modular Leader Cable (TT-MLC-PC), Jumper Cable (TT-JC-PC), Modular End Termination (TT-MET-PC), and/or other sensing cables; check both ends of the cable.
- Test and record the condition of installed sensing cable following the Sensing Cable Test Procedure.
- If practical, connect the installed sensing cable to the TraceTek alarm module. Test the system and put it in operation following the alarm module installation instructions.

At the beginning of the next work day:

- Check that the installed sensing cable is clean and intact following the Sensing Cable Test Procedure. Compare the results with those obtained at the end of the previous work day. If necessary, investigate and correct problems before proceeding.

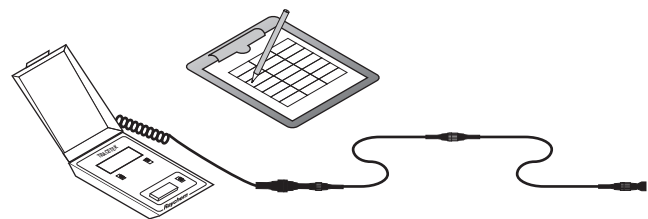

SENSING CABLE TEST PROCEDURE

Method with Raychem TraceTek Portable Text Box (PTB)

1. Ensure the end termination is connected to the sensing cable. If checking several lengths of sensing cable in series (a cable string), ensure they are all connected.
2. Connect the PTB to the sensing cable(s) (using its adapter as needed) as illustrated.
3. **Verify that the sensing cable is intact;** follow the operating instructions printed inside the lid of the PTB itself. If a cable or connection is broken, the PTB illuminates its LED indicating "cable break," and displays a "1" in the leftmost position of its LCD display. If the cable string is intact, the PTB measures the system length.
 - If the cable string is not intact, apply this test procedure to segments of the system to identify the open connection or damaged modular length.
4. **Check the condition of the sensing cable(s),** again following the PTB operating instructions. If the sensing cables are clean and free of contamination, the current measured should be below 10 μA . If the reading exceeds 10 μA , use the PTB to locate the liquid or contamination and take appropriate corrective action.

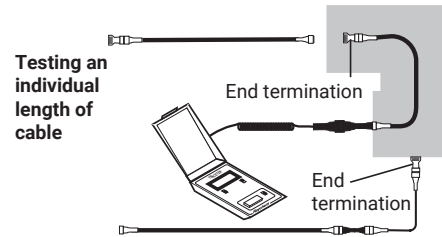
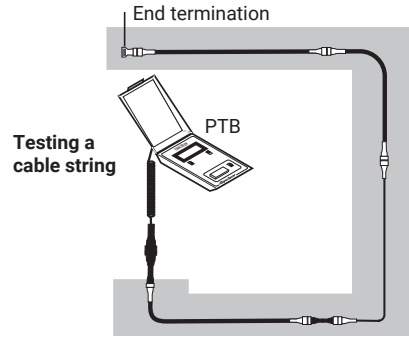

Method with Ohmmeter

1. Ensure the end termination is connected to the sensing cable. If checking several lengths of sensing cable in series (a cable string), ensure they are all connected.
2. Connect a Modular Leader Cable (TT-MLC-PC) to the sensing cable.
3. **Verify that the sensing cable is intact:**

- Loop 1: Measure the resistance between the yellow and black wires of the leader cable as illustrated.
- Loop 2: Measure the resistance between the red and green wires of the leader cable.

The resistance should equal a multiple of the length of sensing cable:
 i.e. 3.9 times the length in feet of sensing cable or 12.8 times the length in meters of sensing cable.

Example: $3.9 \times 50 \text{ ft of cable} = 195 \Omega$
 $12.8 \times 15 \text{ m of cable} = 192 \Omega$

In addition, the resistance of the two loops should be within 5 percent of each other.

If the cable string is not intact, apply this test procedure to segments of the system to identify the open connection or damaged modular length.

Check the condition of the sensing cable. Measure the resistance between the black and green wires of the leader cable.

- If the reading is below 20 megohms, apply this test procedure to segments of the system to identify the modular sensing cable length(s) affected, locate the liquid or contamination, and take appropriate corrective action.

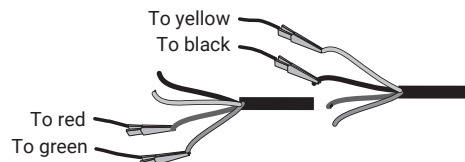
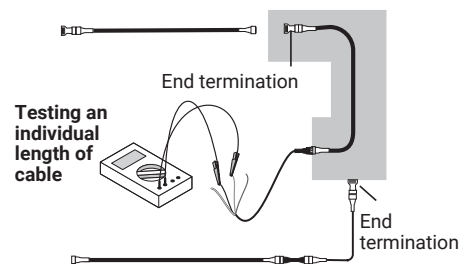
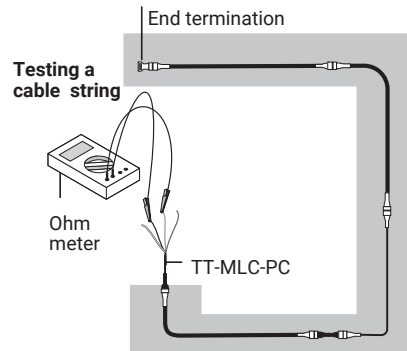

COMPLETE SYSTEM CONNECTIONS AND LAYOUT

- A. TT1100-OHP-THIN is available in a variety of pre-cut and terminated lengths. Each cable has a female plastic connector on one end and a male plastic connector on the opposite end. Cable sections plug together like extension cords.
- B. (Optional) A branch connector (TT-MBC-PC) is used to connect and branch "T" lines. The branch connector has one male connector and two female connectors. For mapping purposes, the cable connected to the center leg of the branch connector will be counted first, then the distance measurements will continue from the second female connector and continue along the rest of the system. A dead band of 15 ft (5 m) is inserted at the beginning and end of each branch to avoid any location ambiguity.
- C. (Optional) It is permissible to have TT-MBCs installed on branches as needed to fully trace a pipe system.
- D. Install an end termination (TT-MET-PC) at the end of the main line and each branch line. (Note: A good check on the system design and bill of materials is that the total number of end terminations installed in the system should equal the number of branch connectors plus one)
- E. (Optional) Install jumper cables (TT-MJC-xxx-PC) as needed to connect sensing cable sections that are located in separate areas. Jumper cable is available in various pre-cut and terminated lengths and is also available in bulk form for long distance runs between the sensing cable and the instrumentation point.
- F. Install a leader cable (TT-MLC-PC) between the sensing cable and the monitoring instrument. The factory standard length of leader cable is 12 ft (4 m). It has a female plastic connector on one end and four tinned leads on the opposite end for connection at the instrument's sensing cable terminal block. In some installations the distance between the instrument and the start of the sensing cable run will be much greater than 12 feet. In those cases a simple solution is to purchase a jumper cable of sufficient length, then cut off and discard the male connector and any extra cable. Bulk jumper cable and connector kits are also available for lengths that exceed the longest available pre-cut jumper cable.
- G. Neatly coil and secure any excess sensing cable, jumper cable, branch connectors, etc.

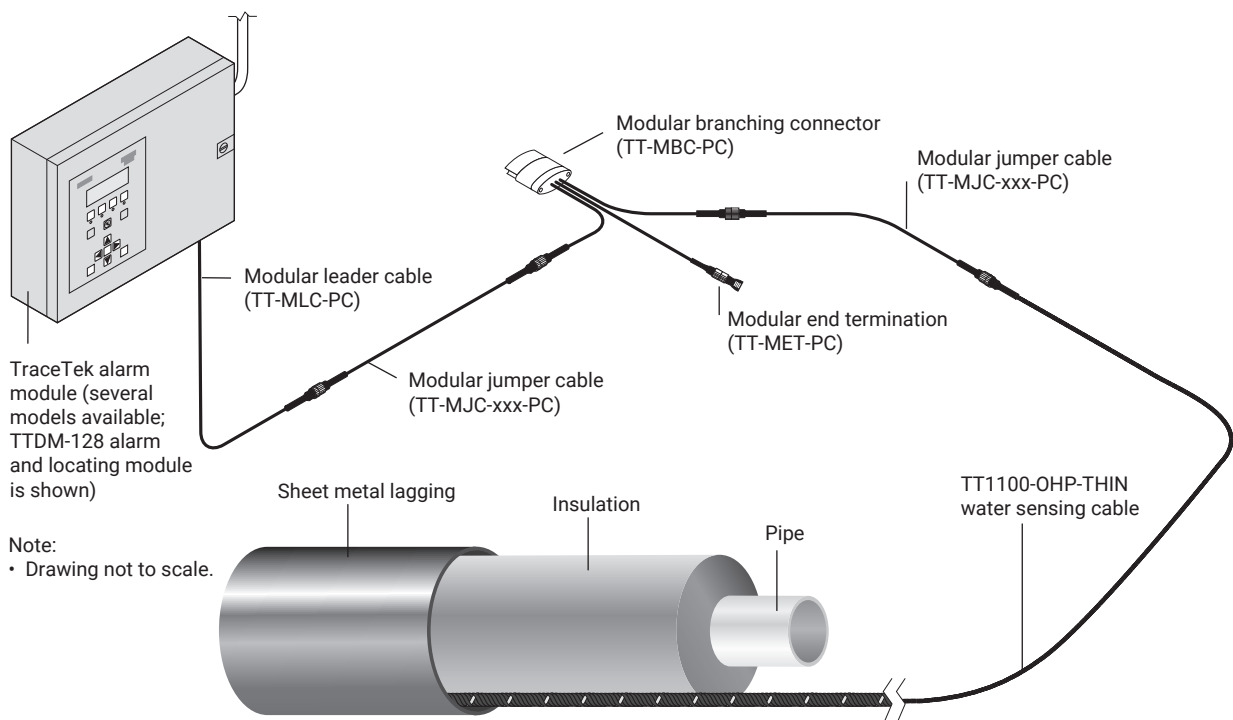

INITIAL POWER-UP AND TEST

Connect the cable to the selected instrument and test the system.

- Apply power to the TraceTek instrument and look for a "Normal" indication.
 - On Raychem TraceTek TTC-1, TTSIM-1A or TTSIM-2 family, there will be a green LED and no other red or yellow LEDs. (On TTSIM-1A and TTSIM-2 the green LED will flicker off every 10 seconds.)
 - On TTSIM-1, Normal Condition is indicated by a steady green LED and a momentary flash of the RED LED every 10 seconds.
 - On TTDM-128 the alpha-numeric display will indicate a channel number and display the words SYSTEM NORMAL.
- If the Yellow LED is on in any of these instruments or the words "Cable Break" or "Loop Break" is displayed, then the cable system must be inspected for loose connections, missing end terminations until the cable continuity is established and the "Normal" condition is achieved.
- LEAK testing can be done with a mapping cap (TT-MAPPING CAP-PC). The MAPPING CAP simulates a leak at the location where it is inserted into the system.
 - For TTC-1, TTSIM-1 and TTSIM-2 a red LED will indicate that the simulated LEAK has been detected.
 - For TTSIM-2 and TTDM-128 a leak location will be displayed in feet or meters (as selected) in addition to the red LED indication
- For larger piping systems with TTDM-128 or TTSIM-2, the MAPPING CAP should be moved sequentially to each accessible connector. Note the distance displayed on the as-built drawings. This will become the basis for the System Map.
- Create a System Map showing where sensing cables and alarm modules have been installed. The System Map will include the beginning and end of sensing cables, and location of any connections. If using locating alarm modules, the System Map should include distance readings at significant landmarks (beginning and end of system, changes of direction, branches, valves, low points, etc.).

TTC-1



TTC-1 Indications:

LEAK LED	Red
CABLE BREAK LED	Yellow
Reset Button	Red
POWER LED	Green

TTSIM-1A

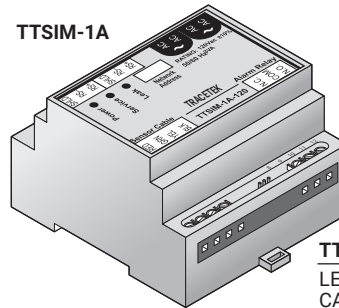

TTSIM-1A Indications:

LEAK	Red
CABLE BREAK	Yellow
SERVICE	Yellow
POWER LED	Green

TTSIM-2

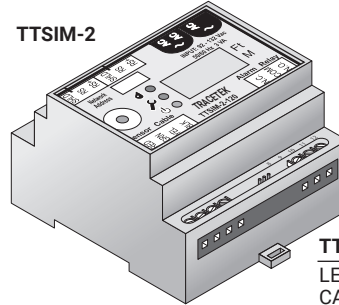

TTSIM-2 Indications:

LEAK	Red
CABLE BREAK	Yellow
SERVICE	Yellow
POWER LED	Green

TTSIM-1

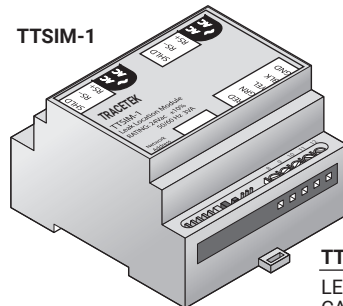

TTSIM-1 Indications:

LEAK	Red
CABLE BREAK	Flashing yellow
SERVICE	Flashing yellow
POWER LED	Green

TTDM-128

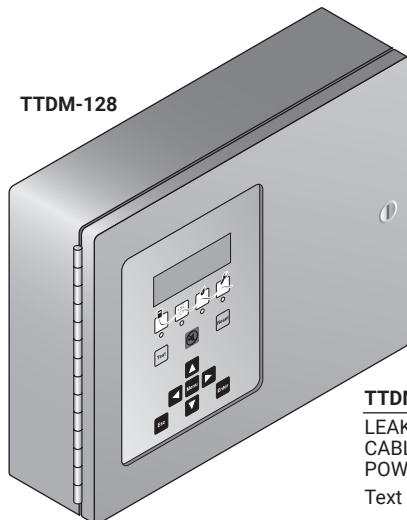

TTDM-128 Indications:

LEAK	Red
CABLE BREAK	Yellow
POWER LED	Green

Text message in 4x20 display

TROUBLESHOOTING

Symptom	Possible Cause and Correction
Green LED not visible on TraceTek instrument	System is not powered. Check power wiring. Check circuit breakers that may have been tripped. On TTDM-128 check fuse and replace if necessary.
Leak alarm (TTDM-128 message and red LED) (SIM Red LED ON)	<p>This is an indication of a LEAK event.</p> <p>For leak locating modules (TTDM-128 and TTSIM-2): Using leak distance indication and System Map as a guide, investigate system condition, work to locate and repair leak.</p> <p>For non-locating modules: Work to locate and repair the leak. (If your system is constructed with multiple sensing cable segments, using an end termination (TT-MET-PC) to break the system into sections can help in locating the leak. Work outward from the alarm module using the end termination to establish a temporary end of the circuit, then sequentially move outward adding one cable segment at a time).</p> <p>Remove any wet insulation.</p> <p>Once the leak is repaired, dry the sensing cable and install over dry insulation. Typically this will clear the Leak Alarm or LEAK condition (Red LED on SIM).</p> <p>In order to clear the Service Req'd (or Service condition), moisture levels on sensing cable and insulation need to be reduced by removing the lagging to allow drying.</p> <p> Note: When the Service Req'd or SERVICE condition exists (Yellow LED), leak location accuracy is reduced for a new leak.</p>
Yellow LED visible on TTC-1, TTSIM-1A, TTSIM-2 or flashing yellow LED on TTSIM-1	<p>Could be cable break or service indication. Refer to alarm module instructions for more information.</p> <p>For Cable break indication:</p> <p>Check for loose connectors, missing end terminations, broken jumper wires or physical damage to the cable. Repair or replace cable if necessary. The TT-MET-PC end termination can be used to isolate a damaged section by working outward from the instrument using the end termination to establish a temporary end of the circuit then sequentially moving outward adding one cable segment at a time.</p>
"SERVICE Req'd" message (TTDM-128 Only)	This is an early warning message from the TTDM-128 panel indicating that the cable is becoming damp, but not yet to the level that constitutes a leak. The TTDM-128 panel may display a location in square brackets. If a location is displayed, that location should be investigated for possible sources of condensation/drips. The square brackets indicated that the leak signal is not strong enough for an accurate location calculation, so the indicated locations may include some error.
Red LED fails to turn off after leak is repaired, and leak alarm reset attempted	Cable and insulation are still damp. Allow more time for cable to dry or investigate leak site to make sure that insulation is dry.
Leak location seems inaccurate in actual leak situation	More than one leak may be present or the cable may be damp in several locations. If the system is monitored by a TTDM-128, check the event history to see if there is an earlier indication of a nearby leak or a SERVICE NEEDED message. If necessary use the end termination to break the system into smaller segments and work outward to isolate each leak location in multiple leak scenarios.
Leak locations seem inaccurate or unstable during mapping tests	Make sure that the simulated leak (MAPPING CAP) is kept in place for at least 30 seconds. The location circuitry in the instruments require a steady leak location in order to compute an accurate distance. Removing the simulated leak too quickly induces a random error.

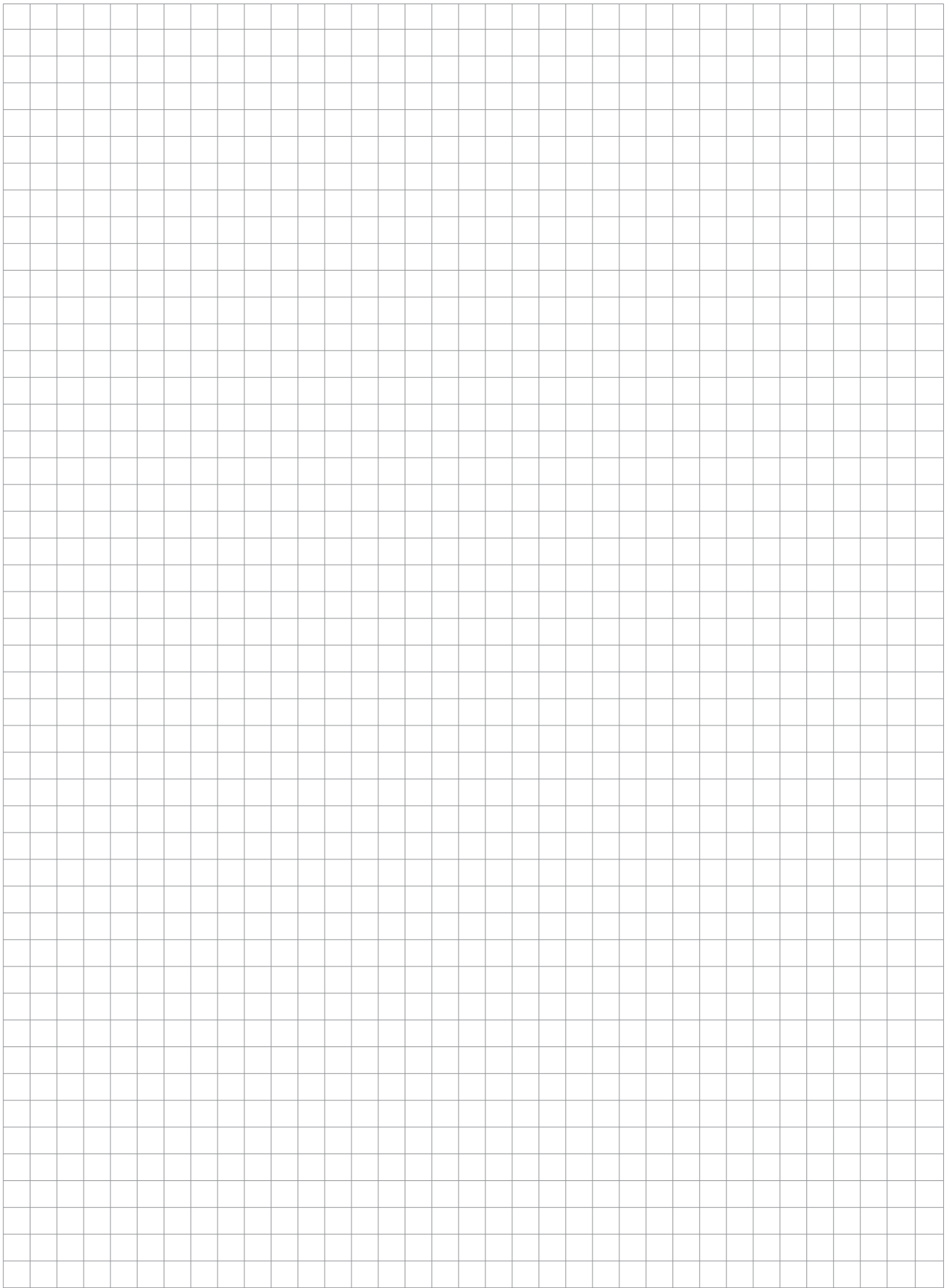

North America

Tel +1 800 545 6258
info@chemelex.com

Latin America

Tel +1 713 868 4800
info@chemelex.com

Europe, Middle East, Africa, India

Tel +32 16 213 511
Fax +32 16 213 604
info@chemelex.com

Asia Pacific

Tel +86 21 2412 1688
infoAPAC@chemelex.com

chemelex
excellence is everything

Raychem Tracer Pyrotenax Nuheat