

# *Raychem*

## TraceTek TT-FFS Fast Fuel Sensors

Installation Manual

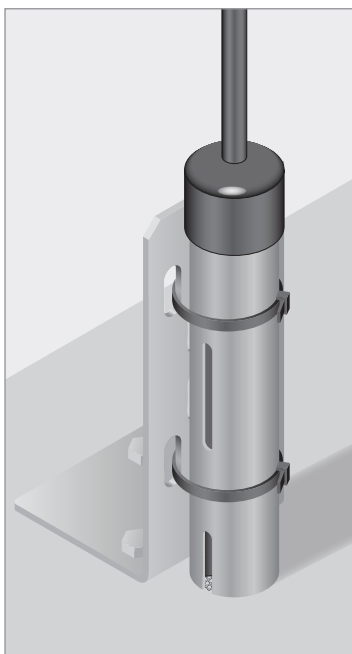

## Important Safeguards and Warnings

The Raychem TraceTek Fast Fuel Sensor (FFS) must be installed correctly to ensure proper operation and detection of spilled hydrocarbons. Read these important warnings and carefully follow all of the installation instructions.

- Approvals and performance are based on the use of Chemelex parts only. Do not substitute parts, particularly the shrink tubing used to seal the connectors.
- All installation and connection should be done without power applied to protect the equipment and the installer.
- Take care not to touch or scratch the sensor material inside the FFS body. Damaging this material will render the unit non-functional.
- Connector heat shrink tubing seals require the use of a heat gun that produces temperatures which can burn exposed skin. Gloves are recommended while using the heat gun and hands kept well out of the way of the air stream.
- The FFS can be damaged if immersed in water and the water freezes. The sensor must be removed from the water prior to freezing (i.e. by draining the area or moving the sensor) or heating measures must be taken to prevent the water from freezing.
- Failure to regularly test or clean the FFS could prevent it from functioning properly and impede or preclude alarm occurrence. Under normal application conditions, test and clean the FFS at least once every 6 months, per the instructions in Section 6 Care and Maintenance. More frequent testing and cleaning may be needed depending on application conditions, particularly if the device is contaminated or covered with foreign materials, e.g. biofilm, fungus, mildew, algae, mud, etc. which could delay or prevent contact of leaked hydrocarbon fuel with the sensor blade coating. Sufficient hydrocarbon fuel must physically contact the sensor blade coating in order for an alarm to occur. Replacement may be necessary if cleaning does not restore the FFS probe.

---

<b>1.</b>	<b>General Information</b>	<b>4</b>
1.1	Use of the Manual	4
1.2	Storage	4
1.3	Safety Guidelines	4
1.4	Approvals	5
1.5	Specific Conditions of Safe Use	5
1.6	Warranty	5

---

<b>2.</b>	<b>Pre-Installation Checks</b>	<b>6</b>
2.1	Tools Required	6
2.2	Installation Components	6
2.3	Pre-Installation Test	6

---

<b>3.</b>	<b>General Installation Instructions</b>	<b>8</b>
3.1	Installation Orientation	8
3.2	Mounting Bracket	8
3.3	Selecting an FFS	8
3.4	Positioning the FFS	10

---

<b>4.</b>	<b>Application Specific Installation Instructions</b>	<b>11</b>
4.1	Diesel Generators - Indoor	11
4.2	Fuel Filters and Valves	13
4.3	Sumps and Run-Off Protection	13
4.4	Fuel Storage Tank Overflow Protection	14
4.5	High Dirt and Wind Environments	16

---

<b>5.</b>	<b>Commissioning Section</b>	<b>17</b>
5.1	Leak Detection System Commissioning	17

---

<b>6.</b>	<b>Care and Maintenance</b>	<b>21</b>
6.1	Cleaning	21
6.2	Functional Testing	21

# 1. GENERAL INFORMATION

---

## 1.1 Use of the Manual

This manual covers installation of the Raychem TraceTek Fast Fuel Sensor (FFS) for hydrocarbon fuel leak detection in commercial and industrial applications. The manual covers general area preparation and sensor installation, wiring details, testing and periodic maintenance for the FFS only.

Other components are required to create a fully functioning hydrocarbon leak detection and alarm system but installation of those components is not covered in this manual. A list of the common product installation manuals which may also be required can be found at [www.chemelex.com](http://www.chemelex.com)

This manual assumes that a proper leak detection system design using the FFS has been completed and that all system components are available and ready for installation.

For additional information contact your local Chemelex Dealer or Representative or contact:

### Chemelex

Tel: +1.800.545.6258

[info@chemelex.com](mailto:info@chemelex.com)

[chemelex.com](http://chemelex.com)



**Important: For warranty and agency approvals to apply, the instructions that are included in this manual and the product packages must be followed.**

## 1.2 Storage

- Store the FFS in a clean dry place in its shipping box until ready for installation.
- Storage temperatures may not exceed  $-40^{\circ}\text{C}$  ( $-40^{\circ}\text{F}$ ) to  $85^{\circ}\text{C}$  ( $185^{\circ}\text{F}$ ).
- Protect the FFS from mechanical damage.

## 1.3 Safety Guidelines

The safety and reliability of any fuel leak monitoring system depends on the quality of the products selected and the manner in which they are installed and maintained. Incorrect design, handling, installation or maintenance of any of the system components could impact the ability of the overall system to detect and report fuel leaks. To minimize these risks and to ensure that the system performs reliably, read and carefully follow the information, warnings and instructions in this guide.

## Pay special attention to the following:

Notes are marked  **Note**

Instructions marked  **Important**

Safety warnings identified as  **Warning**

## 1.4 Approvals

The FFS is approved by FM and Baseefa for use in hazardous areas.



IS/Class I, Div. 1, Groups A, B, C, D/T4; Class I Zone 0, AEx ia IIC T4  
NI/Class I, Div. 2, Groups A, B, C, D/T4; Class I Zone 2, Group IIC T4

Baseefa11ATEX0221X

BAS21UKEX0508X

IECEX BAS 11.0111X



II 1 G

Ex ia IIC T4 Ga ( $-40^{\circ}\text{C} \leq t_a \leq +85^{\circ}\text{C}$ ) ( $U_i = 15\text{ V}$ )

Ex ia IIA T4 Ga ( $-40^{\circ}\text{C} \leq t_a \leq +85^{\circ}\text{C}$ ) ( $U_i = 28\text{ V}$ )

The Fast Fuel Sensor meets the FM 7745 Approval Standard for Diesel Leak Detectors for detecting Diesel Fuel leaks in commercial buildings.

## 1.5 Specific Conditions of Safe Use

- The plastic enclosure poses a potential electrostatic hazard; do not rub or use solvents, clean only with a damp cloth.
- This equipment may not be able to withstand a 500-V isolation test between the circuitry and the monitored medium: this should be taken into account during installation.

## 1.6 Warranty

Chemelex' standard limited 24 month warranty applies to all products.

A copy of the warranty can be found at

<https://www.chemelex.com/support/warranty-information>

## 2. PRE-INSTALLATION CHECKS

---

To ensure an efficient and successful installation, obtain all of the necessary equipment and ensure the installation area is clear of debris and provides a safe working environment.

### 2.1 Tools Required

- Gloves
- Safety Glasses
- Wire Cutters
- Electric Heat Gun
- Specialty Tools — the tools necessary to connect the FFS Mounting Bracket for your specific application. Typical installation areas consist of a concrete floor, metal plate or container or wooden joist. Assemble the tools necessary to secure a bolt or screw into the material for your specific installation area.

### 2.2 Installation Components

- **FFS or FFS-WR**
  - 100 mm version, 1 ft, 3 ft or 10 ft lead, with or without a metal connector
  - 250 mm version, 1 ft, 3 ft or 10 ft lead, with or without a metal connector
- **Raychem TraceTek Probe Tester** – To confirm FFS functionality before installation.
- **Probe Tester Operating Instructions** (H58496)
- **Mounting Bracket Kit** (includes 2 plastic zip ties)
- **Raychem TraceTek Leader Cable** to connect the FFS to the Sensor Interface Module
  - TT-MLC-MC (PN 330065-000) for Indoor Commercial Applications
  - TT-MLC-MC-BLK (PN 133332-000) for Outdoor and Industrial Applications

### 2.3 Pre-Installation Test

Remove the FFS from its packaging and connect it to the Probe Tester using the metal connectors. If your FFS does not have a connector, use the alligator clip adapter to connect it to the Probe Tester.

Once connected, follow the instructions in the Probe Tester Operating Instructions (H58496) to confirm that the FFS is functioning properly.

If the Probe Tester indicates the FFS is in alarm, clean the FFS with Isopropyl Alcohol according to the Care and Cleaning Instructions (H58307). Once the FFS has been cleaned, retest it with the Probe Tester to ensure it is operational.

If the FFS does not reset after this procedure, contact your local Chemelex representative to obtain a replacement unit.

FFS  
(100 mm)



FFS  
(250 mm)



Probe Tester

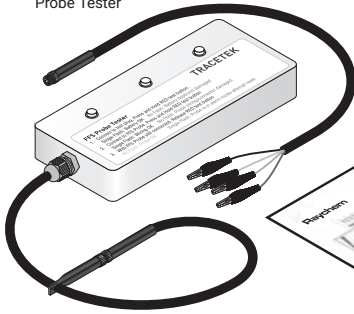

FFS Installation  
Instructions



Mounting Bracket  
and Cable Ties

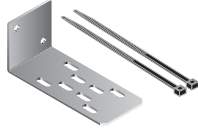

Leader Cable  
- TT-MLC-MC or  
- TT-MLC-MC-BLK

## 3. GENERAL INSTALLATION INSTRUCTIONS

---

### 3.1 Installation Orientation

The FFS is designed to be mounted upright with the leader cable coming out of the top. This positions the sensor as close to the floor or fuel location as possible and minimizes the amount of fuel required to trigger an alarm. This orientation is recommended whether the FFS is mounted on a floor, in a sump or in a floating assembly. Regardless of the mounting hardware used, this is the recommended mounting position.

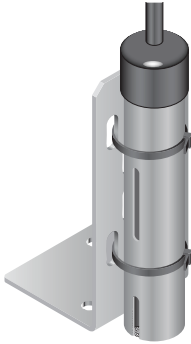

### 3.2 Mounting Bracket

A Mounting Bracket kit is available which includes a versatile stainless steel bracket with zip ties to secure the FFS in position. The mounting bracket includes a variety of round and oval openings which accept fasteners up to 0.250" (M6). This kit provides a simple way to mount the FFS to a variety of surfaces and structures.



### 3.3 Selecting an FFS

The FFS comes in two lengths; 250 mm and 100 mm. The 100 mm devices are suitable for general use in fuel detection where the fuel will spill onto a floor or other surface. The 250 mm devices are designed to be used in sumps and other applications where fuel may pool or collect on the surface of water and the water level may vary due to rain or other sources. The longer 250 mm sensor length will remain effective for larger variations in water level than the 100 mm device.

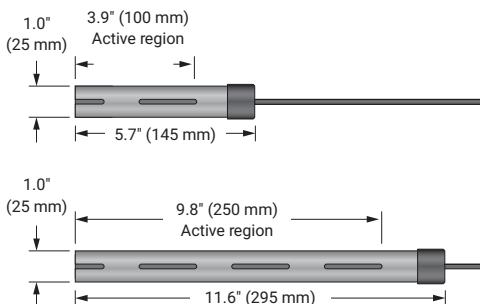

The FFS is also available in two versions. The TT-FFS-WR versions are specially designed for wet environments and are recommended for outdoor applications. The standard TT-FFS can be used for indoor applications and any FM7745 compliant installations. Refer to the FFS Data Sheet (H57977) for part numbers.

**Note:** While the FFS is water-resistant, it is not intended for applications where it is permanently immersed in water. Refer to the FFS Data Sheet (H57977) for guidance on water resistant capability.

**Warning:** The FFS can be damaged if immersed in water and the water freezes. The sensor must be removed from the water prior to freezing (i.e. by draining the area or moving the sensor) or heating measures must be taken to prevent the water from freezing.

**Warning:** Failure to regularly test or clean the FFS could prevent it from functioning properly and impede or preclude alarm occurrence. Under normal application conditions, test and clean the FFS at least once every 6 months, per the instructions in Section 6 Care and Maintenance. More frequent testing and cleaning may be needed depending on application conditions, particularly if the device is contaminated or covered with foreign materials, e.g. biofilm, fungus, mildew, algae, mud, etc. which could delay or prevent contact of leaked hydrocarbon fuel with the sensor blade coating. Sufficient hydrocarbon fuel must physically contact the sensor blade coating in order for an alarm to occur. Replacement may be necessary if cleaning does not restore the FFS probe.

Varying lengths of leader cable are available on the FFS as well as an option to include a connector.

- Select from 1', 3' or 10' leader cable lengths depending on the needs of your particular application. If the FFS is to be mounted in a float assembly, the 10' leader is recommended to accommodate the up/down travel of the float assembly as the water level varies.
- End termination options include a water tight connector compatible with other Raychem TraceTek cables or simple pig-tailed leads. The connectors have the advantage of straightforward connection in the field and a water-sealed interface when assembled in accordance with the manufacturer's recommendations. The simple pig-tailed leads can be used if the FFS is to be connected to terminal blocks in a junction box or similar enclosure.



If a FFS model with metal connector is selected, be sure to install the heat shrinkable tube over the mated male/female (pin/socket) connections.

- Move the heat-shrinkable tube along the sensing cable until it is centered over the mated connection.
- Using a heat gun, shrink the tube over the connection. Begin in the center and shrink toward each end until tube fully conforms to the shape of the connection.

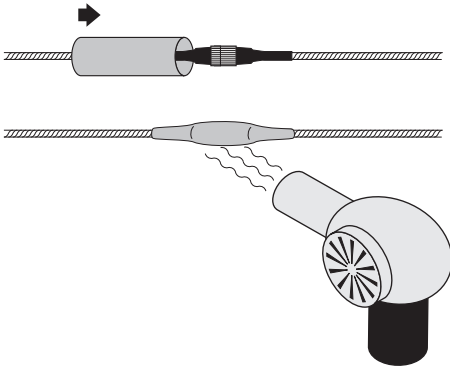

### 3.4 Positioning the FFS

The FFS should be placed in a location which is protected from damage due to normal vehicle, personnel or equipment traffic but highly likely to come in contact with any leaked fuel.

This includes consideration of low points in the floor where leaked fuel may pool or equipment locations, such as fuel tanks, fuel line valves and filters, where leaks are most likely to occur.

The recommended mounting configuration of the FFS is with the open end touching the floor. This positions the sensor board as close to the floor as possible allowing it to detect any fuel spill as quickly as possible.

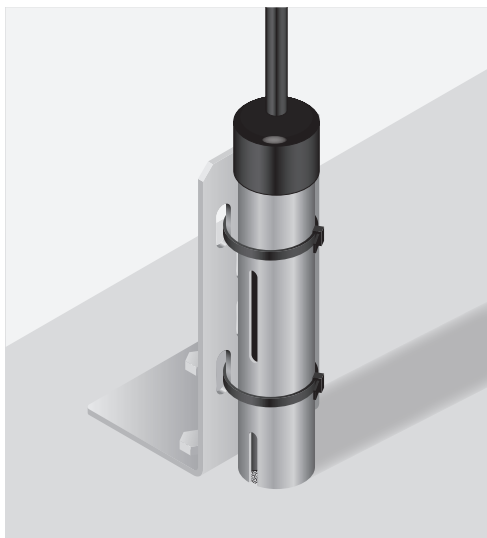

The FFS body should be secured to the mounting bracket via zip ties or some other removable retention mechanism. It may be desirable to move the FFS out of the way during equipment maintenance, either to protect it from damage or prevent a false alarm due to fuel spilled during maintenance activities. Therefore, the retention method used should allow easy removal and re-installation.

## 4. APPLICATION SPECIFIC INSTALLATION INSTRUCTIONS

---

The following sections provide installation instructions and recommendations for some of the standard fuel leak detection applications.

### 4.1 Diesel Generators - Indoor

The first step to installing the FFS for leak detection around diesel generators is to define the location of the sensor.

- If the diesel generator is installed in a recessed area which is designed to contain any leaked fuel, then the FFS should be mounted in the recessed area.
  - Find the ideal mounting location by spilling water at different spots within the recessed area to determine the point to which most spilled fluid will flow to.
  - Mount the FFS in this spot.

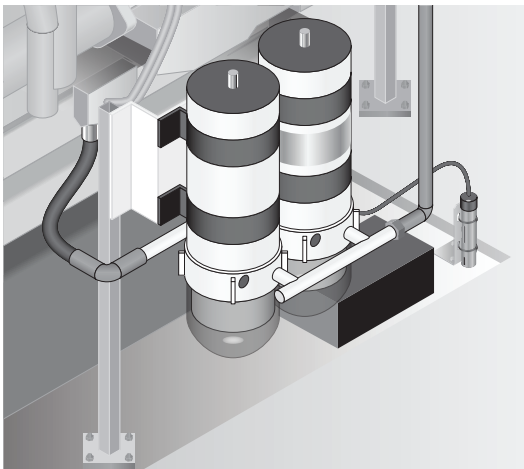

- If the diesel generator is not recessed, then it is recommended that a weir be constructed around the generator to contain any leaked fuel. The FFS should then be mounted within the weir to ensure contact with any leaked fuel.
  - $\frac{3}{4}$ " (2 cm) angle iron or similar can be used to construct the weir.
    - Secure to the floor using appropriate bolts, screws or glues.
    - Seal the corners and floor interfaces to prevent fuel leakage out of the weir.
  - Find the ideal mounting location by spilling water at different spots within the weir to determine the point to which any spilled fluid will flow.
  - Mount the FFS in this spot.

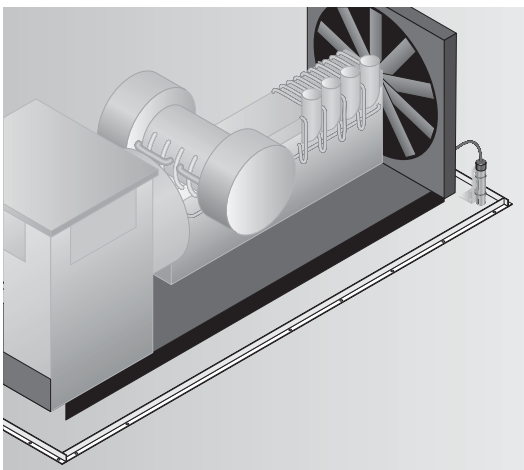

## 4.2 Fuel Filters and Valves

Fuel Filters, Valves and other points at which pipes interface or connect represent the highest probability of becoming a leak point. A weir should be built around the potential leak point or equipment to contain any leaked fuel.

- $\frac{3}{4}$ " (2 cm) angle iron or similar can be used to construct the weir.
  - Secure to the floor using appropriate bolts, screws or glues.
  - Seal the corners and floor interfaces to prevent fuel leakage out of the weir.
- The FFS should then be mounted within the weir.

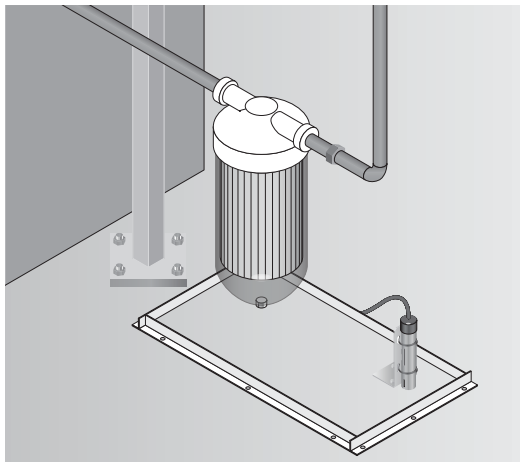

## 4.3 Sumps and Run-Off Protection

The FFS may be used to detect pooling of leaked fuel in water sumps or fuel floating on water in sumps, water storage pools and storm drains, etc. The TT-FFS-WR version is recommended for all water exposed applications.

If your application requires the FFS to be used in a float system to detect fuel leaks and contamination on top of the water, then refer to the TraceTek FFS and Float Assembly Installation Manual (H59200) for complete details on this type of installation.

Fixed location installation of the FFS in sumps and drains may be accomplished by fixing the mounting bracket directly to the wall of the sump with the right angle bend at the bottom and facing out. This provides support for the FFS so that it does not simply slip out of the zip ties over time. Mounting location should be chosen such that the FFS is centered in the desired fuel detection zone of the sump or drain. The 250 mm version of the FFS is recommended for these installations as it provides a longer sensor and can accommodate larger variations in water level.



**⚠ Warning: The FFS can be damaged if immersed in water and the water freezes. The sensor must be removed from the water prior to freezing (i.e. by draining the area or moving the sensor) or heating measures must be taken to prevent the water from freezing.**

**⚠ Warning: Failure to regularly test or clean the FFS could prevent it from functioning properly and impede or preclude alarm occurrence. Under normal application conditions, test and clean the FFS at least once every 6 months, per the instructions in Section 6 Care and Maintenance. More frequent testing and cleaning may be needed depending on application conditions, particularly if the device is contaminated or covered with foreign materials, e.g. biofilm, fungus, mildew, algae, mud, etc. which could delay or prevent contact of leaked hydrocarbon fuel with the sensor blade coating. Sufficient hydrocarbon fuel must physically contact the sensor blade coating in order for an alarm to occur. Replacement may be necessary if cleaning does not restore the FFS probe.**

#### **4.4 Fuel Storage Tank Overflow Protection**

Large Fuel Storage Tank overflow protection is normally provided at two points as necessary:

1. Within the overflow containment ring around the bottom of the tank
2. On the roof for tanks utilizing floating roof systems

If the fuel storage tanks are located outdoors, then the TT-FFS-WR version of the FFS is recommended.

##### **Overflow Containment Ring Installations**

The FFS can be mounted anywhere in the overflow containment ring that is convenient. It is recommended that the placement be against the tank side of the containment ring in order to protect it from damage. Installation of the FFS should be flush with the bottom of the containment ring surface.

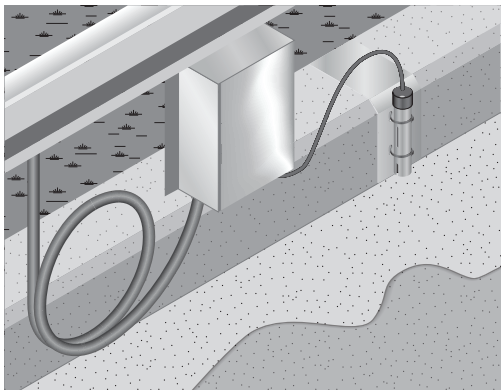

**⚠ Warning:** The FFS can be damaged if immersed in water and the water freezes. The sensor must be removed from the water prior to freezing (i.e. by draining the area or moving the sensor) or heating measures must be taken to prevent the water from freezing.

**⚠ Warning:** Failure to regularly test or clean the FFS could prevent it from functioning properly and impede or preclude alarm occurrence. Under normal application conditions, test and clean the FFS at least once every 6 months, per the instructions in Section 6 Care and Maintenance. More frequent testing and cleaning may be needed depending on application conditions, particularly if the device is contaminated or covered with foreign materials, e.g. biofilm, fungus, mildew, algae, mud, etc. which could delay or prevent contact of leaked hydrocarbon fuel with the sensor blade coating. Sufficient hydrocarbon fuel must physically contact the sensor blade coating in order for an alarm to occur. Replacement may be necessary if cleaning does not restore the FFS probe.

### Floating Roof Installations

The FFS can be used to detect breaks in the seal between the tank wall and roof for floating roof systems. A single or several FFS may be mounted on the floating roof at its perimeter.

- The mounting bracket may be used with an appropriate connection method to ensure the roof integrity is not compromised.
- Sufficient jumper or leader cable must be used to allow full range of roof motion without creating any tension on the FFS connector or connection cable(s).

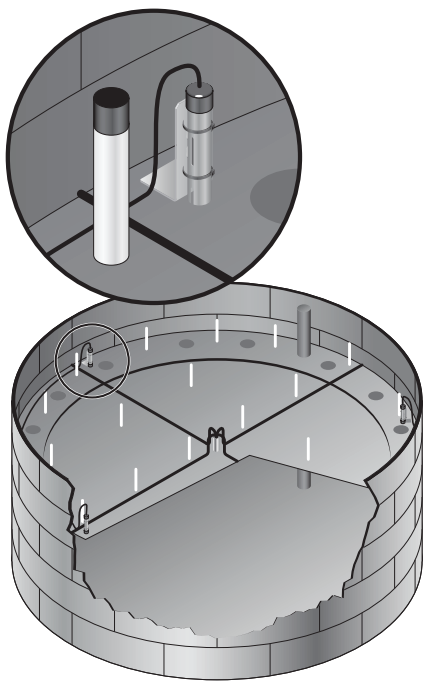

#### 4.5 High Dirt and Wind Environments

For applications in which the FFS is subjected to high winds and potentially abrasive materials like sand, the Extreme Environmental Cover is recommended. The cover blocks blown dust and debris from abrasively damaging the Fuel Sensor material but allows leaked fuel to flow up from the bottom and through the holes in the cover to reach the sensor. Using the cover will prolong the life of the FFS when used in outdoor environments.

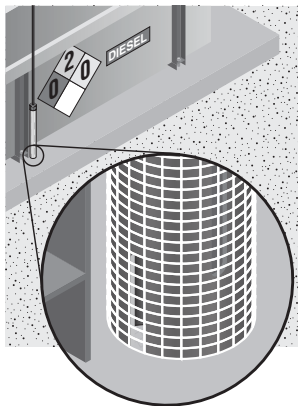

This cover comes in two versions, one for each size of the FFS.

- TT-FFS-EEC-100, Part Number: P000001142
- TT-FFS-EEC-250, Part Number: P000001143

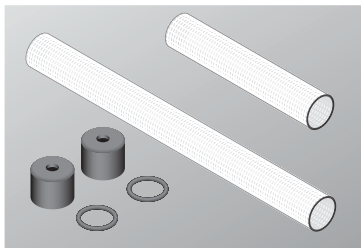

Detailed installation instructions for assembling the Extreme Environmental Cover (EEC) onto the FFS are provided in the EEC Installation Instructions (H58519).

## 5. COMMISSIONING SECTION

---

Once installed, both the FFS and the Raychem TraceTek Leak Detection System should be tested to confirm an alarm will be generated at the point of user interface. The user interface could be the Sensor Interface Module (TTSIM), TTC-1, a Raychem TraceTek master controller (TS12 or TTDM-128) or a custom built interface connected to an Raychem TraceTek controller provided by a third party. FFS functional testing can only be performed by applying a hydrocarbon fluid to the sensor and monitoring the response. Therefore, two methods of Leak Detection System and FFS testing are provided. The first procedure leaves the FFS installed in place and exposes it to a hydrocarbon. Since application of a hydrocarbon in the FFS mounting location may not be allowed by facility regulations, a second procedure is provided where the FFS and the Leak Detection System response are confirmed separately. This allows the FFS to be functionally tested in a safe area if desired.

### 5.1 Leak Detection System Commissioning

**⚠ Warning: Functional testing requires the use of hydrocarbons which can be flammable. Even though very small amounts of the recommended hydrocarbons are necessary to create a leak alarm from the FFS, they are still exposed to the environment and present an ignition risk. Use caution when handling these materials to minimize the risk of ignition. Check with your facility regulations to ensure the testing recommended below is within the local guidelines. If they are not, then functional testing must be done in an approved location.**



**Note:** Creating a leak indication with the FFS can be accomplished using a low viscosity, quickly evaporating hydrocarbon such as naphtha or lighter fluid. These materials will produce the desired hydrocarbon detection response from the FFS while quickly evaporating and allowing the FFS to reset. Higher viscosity hydrocarbons can be used but the time required to reset the FFS for operation will be longer. Additionally, high viscosity hydrocarbons will, over time and multiple test sequences, resist cleaning and eventually the FFS will not reset. Therefore, the low viscosity, quickly evaporating materials are highly recommended.

### 5.1.1 Functional Testing – FFS in System

Where possible, functional testing of the FFS with it connected in the full Raychem TraceTek system is preferred as this will validate functionality of the system in addition to that of the FFS.



**Warning: Before handling any flammable hydrocarbon, remember to put on the appropriate personal protective equipment (PPE). Fuel resistant gloves and safety glasses are the minimum requirement. Check with your local safety requirements and follow their procedures for PPE and handling of flammable liquids.**



**Warning: When applying fluid to the FFS, be sure not to touch the sensor material with the fluid applicator (dropper, pipette or spray tip, etc.). Doing so may damage the sensor and render the FFS inoperable.**

To functionally test the FFS use the following procedure:

1. Verify that the leak detection circuit using the FFS is not in alarm nor has any service or trouble alarms. If any of these alarms exist on the circuit, then fix them before proceeding further.
  - a. Verify that no alarms exist at the Sensor Interface Module (TTSIM) or TTC-1.
  - b. If applicable, verify that no alarms exist at the master controller (TS12 or TTDM-128).
  - c. If applicable, verify that any third party systems are not indicating an alarm.
2. Apply a small amount of the test hydrocarbon fluid to the sensor board inside the orange FFS housing.
  - d. Five (5) drops of a low viscosity hydrocarbon like naphtha should be sufficient to create an alarm response from the FFS.
  - e. Keep the applicator tip outside of the orange FFS cover.
3. Check the alarm output from the TTSIM or TTC-1.
  - f. The Leak LED should be lit.
4. If applicable, check the alarm output from the master controller to confirm that an alarm has been generated by the FFS.
  - g. TS12 – Audible alarm will sound and the appropriate circuit listing on the touch screen display will turn red.
  - h. TTDM-128 – Audible alarm will sound, the Leak LED on the front panel will light and a leak notification will be displayed on the LCD text display for the appropriate circuit.

- i. If a fast response is not observed, check the Alarm Delay settings to ensure that the alarm delays are not set to a large value.
- 5. If applicable, check the alarm output from the third party system to confirm that an alarm has been generated by the FFS.
  - j. Refer to the third party system information to determine the appropriate leak alarm response.
- 6. If an alarm is not observed after the Alarm Delay times, clean the probe according to the Care and Cleaning instructions (H58307) to ensure no contamination is preventing the test fluid from contacting the sensor board, and retest. Or contact your local Chemelex representative.
- 7. Once the leak detection alarm has been confirmed, reset the FFS. If a light hydrocarbon such as naphtha was used, the FFS will automatically reset after a few hours due to evaporation. If a heavier hydrocarbon was used, follow the cleaning procedure specified in the FFS Care and Cleaning Instructions (H58307).
- 8. Confirm that the FFS has reset and is ready for use. Confirm that all alarms in the Leak Detection System are cleared and reset.

### **5.1.2 Functional Testing – Separate FFS Testing**

If it is not suitable to functionally test the FFS where it is installed due to safety or other considerations, the Leak Detection controllers/ alarm panels and the FFS can be tested separately. The Leak Detection controllers/alarm panels can be tested by attaching a Mapping Cap (Part number P000000871, TT-MAPPING-CAP-MC) at the end of the Modular Leader Cable, to simulate a leak. The FFS may be removed from its location and functionally tested using the portable battery operated Probe Tester (Part number P000001048, TT-FFS PROBE TESTER) or any appropriate TraceTek controller located in a safe location.

#### **Leak Detection Controllers/Alarm Panels Functional Testing**

To verify that the Leak Detection System controllers/alarms and leader/jumper cables are functioning correctly use the following procedure:

- 1. Verify that the leak detection circuit using the FFS is not in alarm nor has any service or trouble alarms. If any of these alarms exist on the circuit, they must be fixed before attempting to connect and functionally test the FFS.
  - k. If applicable, verify that no alarms exist at the Sensor Interface Module (TTSIM), TTC-1 or other Raychem TraceTek controller.
  - l. If applicable, verify that no alarms exist at the master controller (TS12 or TTDM-128).
  - m. If applicable, verify that any third party systems are not indicating an alarm.
- 2. Remove the FFS from its mounting bracket and unscrew the metal connector. It will be necessary to remove the shrink tube seal which should have been applied over the connectors. Refer to Oversleeve Removal Instructions (H54258).
- 3. Connect the Mapping Cap to the jumper cable in place of the FFS. (The Mapping Cap simulates a leak alarm at the sensor location).
- 4. Check the alarm output from the TTSIM or TTC-1.
  - n. The Leak LED should be lit.

5. If applicable, check the alarm output from the master controller to confirm that an alarm has been generated by the Mapping Cap.
  - o. TS12 – Audible alarm will sound and the appropriate circuit listing on the touch screen display will turn red.
  - p. TTDM-128 – Audible alarm will sound, the Leak LED on the front panel will light and a leak notification will be displayed on the LCD text display for the appropriate circuit.
  - q. If an immediate response is not observed, check the Alarm Delay settings to ensure that the alarm delays are not set to a large value.
6. If applicable, check the alarm output from the third party system to confirm that an alarm has been generated by the Mapping Cap.
  - r. Refer to the third party system information to determine the appropriate leak alarm response.
7. If an alarm is not observed after the Alarm Delay times, there may be an issue with the cabling or the Mapping Cap connection. First confirm that the Mapping Cap is properly connected to the jumper cable. If the system continues to indicate that there is no leak on that circuit, then more in-depth troubleshooting is required. Refer to the Sensor Interface Module or Master Control system manuals or contact your local Chemelex representative for assistance.
8. Once the leak detection alarm has been confirmed, the Mapping Cap may be replaced with the functionally tested FFS.

### **FFS Functional Testing in a Safe Location**

To functionally test the FFS, use the following procedure:

1. Remove the FFS from its mounting bracket and unscrew the metal connector. It will be necessary to remove the shrink tube seal which should have been applied over the connectors. Refer to Oversleeve Removal Instructions (H54258). Transport the FFS to the safe test area. The FFS may either be tested with a Controller or a Probe Tester.  
If using a Probe Tester, follow steps 2) through 8) below. If using an Raychem TraceTek controller, connect the FFS to the controller, and follow steps 1) through 8) shown on pages 18-19 Section 5.1.1.
2. Connect the FFS to the Probe Tester.
  - s. If the LEDs on the Probe Tester do not flash, proceed to Step 3.
  - t. If the LEDs on the Probe Tester begin to flash immediately (once every second), then the FFS is indicating that it is already in alarm. Remove the FFS and clean it using the procedure defined in the TT-FFS. Care and Cleaning Instructions (H58307).
3. With the FFS connected to the Probe Tester, press and hold the red button on the Probe Tester. All three LED's on the front of the Probe Tester should flash once per second. This indicates that the FFS is connected, functional and not in alarm. Release the Red button on the Probe Tester.
4. Apply a small amount of the test hydrocarbon fluid to the sensor board inside the orange FFS housing. Five (5) drops of a low viscosity hydrocarbon like naphtha or lighter fluid should be sufficient to create an alarm response from the FFS.
5. The three LEDs on the Probe Tester should begin to flash once per second within 10 seconds of applying the hydrocarbon to the sensor board.

- u. If a fast response is not observed, confirm that the hydrocarbon did contact the grey material on the sensor board inside the orange housing.
  - v. Apply additional hydrocarbon if necessary.
  - w. If there is no response, contact your local Chemelex representative for assistance.
6. Once the leak detection alarm has been confirmed, clean the FFS using the procedure specified in the FFS Care and Cleaning Instructions (H58307).
  7. Confirm that the FFS has reset and is ready for use by connecting it to the Probe Tester and verifying that the LEDs do not flash until the Red Button has been pushed.
  8. The unit may now be returned to service. If a FFS model with metal connector was tested, be sure to install a heat shrinkable tube (TT-COS, PN 642079-000) over the mated male/female (pin/socket) connections.

## 6. CARE AND MAINTENANCE

---

Regular care and maintenance of the FFS is recommended, particularly for outdoor applications. The FFS should be cleaned and functionally checked at least once every six (6) months to confirm operation. More frequent testing and cleaning may be needed depending on application conditions, particularly if the device is contaminated or covered with foreign materials, e.g. biofilm, fungus, mildew, algae, mud, etc. which could delay or prevent contact of leaked hydrocarbon fuel with the sensor blade coating.

### 6.1 Cleaning

Cleaning Instructions for the FFS are provided in the FFS Care and Cleaning Instructions (H58307). This process is used during both maintenance and to reset the FFS if it has been in contact with hydrocarbons from a real leak.

### 6.2 Functional Testing

Functional testing may be performed with the FFS in place or separately using the Probe Tester.

#### System Functional Testing

If functional testing of the complete system is desired, refer to the test steps in the Commissioning Section 5.1.1.

#### FFS Only testing

If only the FFS is to be tested with the Probe Tester, use the following procedure:



**Warning: Functional testing requires the use of hydrocarbons which can be flammable. Even though very small amounts of the recommended hydrocarbons are necessary to create a leak alarm from the FFS, they are still exposed to the environment and present an ignition risk. Use caution when handling these materials to minimize the risk of ignition. Check with your facility regulations to ensure the testing recommended below is within the local guidelines. If they are not, then functional testing must be done in an approved location.**

 **Warning: Before handling any flammable hydrocarbon, remember to put on the appropriate personal protective equipment (PPE). Fuel Resistance gloves and safety glasses are the minimum requirement. Check with your local safety requirements and follow their procedures for PPE and handling of flammable liquids.**

 **Warning: When applying fluid to the FFS, be sure not to touch the sensor material with the fluid applicator (dropper, pipette or spray tip, etc.). Doing so may damage the sensor and render the FFS inoperable.**



**Note:** Functional testing can be done using a low viscosity, quickly evaporating hydrocarbon such as butane or lighter fluid. These materials will produce the desired hydrocarbon detection response from the FFS while quickly evaporating and allowing the FFS to reset. Higher viscosity or more readily available hydrocarbons can be used but the time required to reset the FFS for operation will be longer. Additionally, high viscosity hydrocarbons will, over time and multiple test sequences, resist cleaning and eventually the FFS will not reset. Therefore, the low viscosity, quickly evaporating materials are highly recommended.

To functionally test the FFS with the Probe Tester, use the following procedure:

1. Remove the FFS from its mounting bracket and unscrew the metal connector. It will be necessary to remove the shrink tube seal which should have been applied over the connectors. Refer to Oversleeve Removal Instructions (H54258). Transport the FFS to the test area.
2. Connect the FFS to the Probe Tester.
  - x. If the LEDs on the Probe Tester begin to flash immediately (once every second), then the FFS is indicating that it is already in alarm. Remove the FFS and clean it using the procedure defined in the FFS Care and Cleaning Instructions (H58307).
  - y. If the LEDs on the Probe Tester do not flash, proceed to Step 3.
3. With the FFS connected to the Probe Tester, press and hold the red button on the Probe Tester. All three LED's on the front of the Probe Tester should flash once per second. This indicates that the FFS is connected, functional and not in alarm. Release the Red button on the Probe Tester.
4. Apply a small amount of the test hydrocarbon fluid to the sensor board inside the orange FFS housing. Five (5) drops of a low viscosity hydrocarbon like butane should be sufficient to create an alarm response from the FFS.
5. The three LEDs on the Probe Tester should begin to flash once per second within 10 seconds of applying the hydrocarbon to the sensor board.
  - z. If an immediate response is not observed, confirm that the hydrocarbon did contact the grey material on the sensor board inside the orange housing.
  - aa. Apply additional hydrocarbon if necessary.

6. Once the leak detection alarm has been confirmed, clean the FFS using the procedure specified in the FFS Care and Cleaning Instructions (H58307).
7. Confirm that the FFS has reset and is ready for use by connecting it to the Probe Tester and verifying that the LEDs do not flash until the Red Button has been pushed.
8. The unit may now be returned to service. If a FFS model with metal connector was tested, be sure to install a heat shrinkable tube (TT-COS, PN 642079-000) over the mated male/female (pin/socket) connections.

## **North America**

Tel +1 800 545 6258  
info@chemelex.com

## **Latin America**

Tel +1 713 868 4800  
info@chemelex.com

## **Europe, Middle East, Africa, India**

Tel +32 16 213 511  
Fax +32 16 213 604  
info@chemelex.com

## **Asia Pacific**

Tel +86 21 2412 1688  
infoAPAC@chemelex.com

---

**chemelex**  
*excellence is everything*

[chemelex.com](http://chemelex.com)

**Raychem Tracer Pyrotenax Nuheat**

©2026 Chemelex. All Chemelex marks and logos are owned or licensed by Chemelex Europe GmbH or its affiliates. All other trademarks are the property of their respective owners. Chemelex reserves the right to change specifications without notice.

RAYCHEM-IM-H59322-TTFS-EN-2602