

Raychem

AMG-BS-III

AutoMatrix Splice Connection Kit Installation Instructions

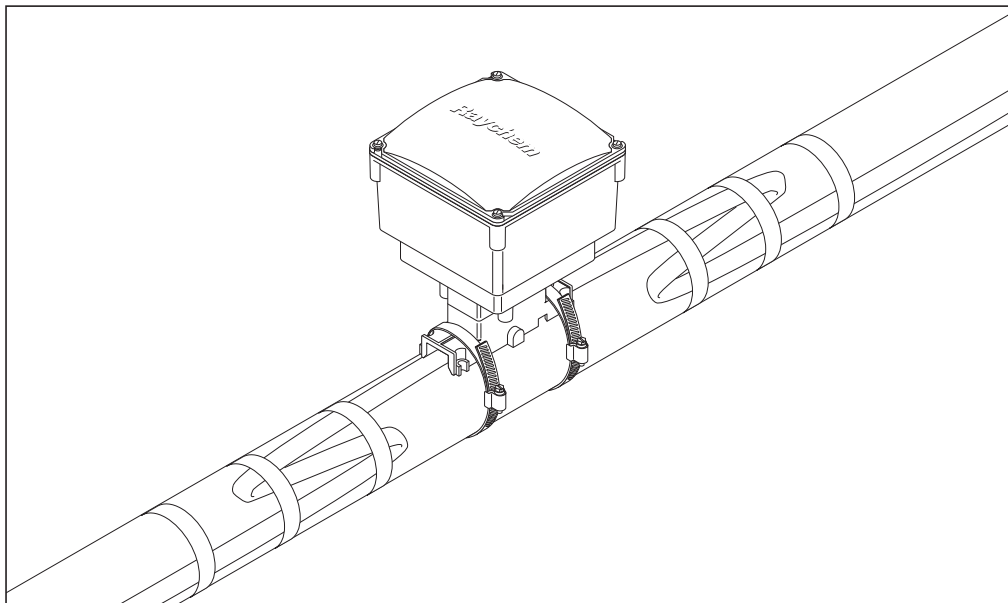

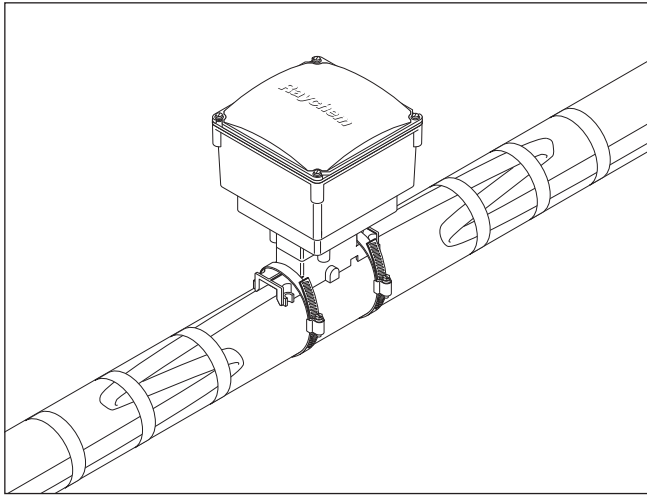

DESCRIPTION

The Raychem AMG-BY-III is a copper free aluminum (maximum 4/10 of 1% copper) NEMA 4X(1) rated splice connection kit.

The kit contains materials for one splice connection.

TOOLS REQUIRED

- Screwdriver
- Wire cutters
- Adjustable pliers
- 1/4 in nut driver
- Crimp tool
- Needle-nose pliers
- Utility knife
- Heat gun or mini-torch
- 3/8 in nut driver

ADDITIONAL MATERIALS REQUIRED

- Pipe straps
- Grommets⁽²⁾
- GT-66 tape⁽³⁾. Installation temp. above 40° F
- GS-54 tape⁽³⁾. Installation temp. above -40° F

⁽¹⁾ This type 4X enclosure is intended for indoor or outdoor use primarily to provide a degree of protection against corrosion, windblown dust and rain, splashing water, and hose-directed water. It is not suitable for use where subject to attack by alkalis.

⁽²⁾ May be required (see step 1).

⁽³⁾ Required for CSA Class I, II, III Division 2 Certification (see step 12)

APPROVALS

Hazardous Locations



NEMA 4X

Class I, Div. 2, Groups B, C, D
Class II, Div. 2, Groups F, G
Class III, Div. 2



TYPE 4X

Class I, Div. 2, Groups A, B, C, D
Class II, Div. 2, Groups F, G
Class III, Div. 2

KIT CONTENTS

Item	Qty	Description	Part No
A	1	Connection box assembly	911161
	1	Connection box lid	
	1	Lid gasket	
	1	Connection box	
	1	Pressure plate	
	1	Base gasket	
	1	Connection base	
	10	Connection box screws	
B	1	Grounding locknut (green)	990335
C	2	Pressure plate screws (1" SS)	730141
D	1	Terminal block assembly	633473
E	2	Core insulator kit	463319
	1	Red grommet	
	1	Ring terminal	
	1	Green/yellow heat-shrinkable tube	
	1	Clear yellow heat-shrinkable tube	
	2	Black heat-shrinkable tubes	

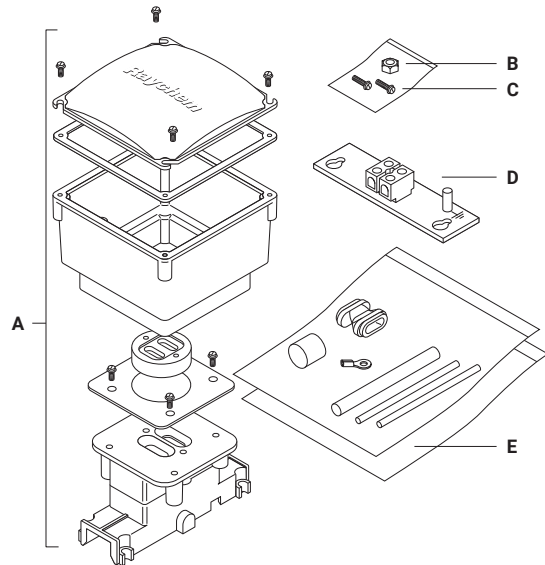

WARNING:

This component is an electrical device which must be installed correctly to ensure proper operation and to prevent shock or fire. Read these important warnings and carefully follow all the installation instructions.

- To minimize the danger of fire from sustained electrical arcing if the heating cable is damaged or improperly installed, use a ground fault protection device (GFPD). Arcing may not be stopped by conventional circuit breakers.
- Component approvals and performance are based on the use of specified parts only. Do not use substitute parts or vinyl electrical tape.

- The black heating cable core and fibers are conductive and can short. They must be properly insulated and kept dry.
- Damaged bus wires can overheat or short. Do not break bus wire strands when scoring the jacket or core.
- Heat damaged components can short. Use a heat gun or a torch with a soft, yellow, low-heat flame, not a blue focused flame. Keep the flame moving to avoid overheating, blistering, or charring the heat-shrinkable tubes. Avoid heating other components. Replace any damaged parts.

CAUTION:

Overheating heat-shrinkable tubes will produce fumes that may cause irritation. Use adequate ventilation and avoid charring or burning. Consult MSDS RAY/3122 for further information.

CHEMTREC 24-hour emergency telephone:
(800) 424-9300

Non-emergency health and safety information:
(800) 545-6258.

Heating cable types

1

- Identify heating cable type.
- Select correct grommet from chart on right.

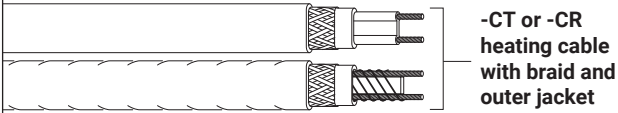

Heating Cable	Type	Grommet (10/pack)	Part No.
BTV, QTVR, XTV	-CT or -CR	RED	725157
KTV	-CT	P*	700823
LBTV**	-CT or -CR	K*	222724

* Order separately

** Requires terminal block assembly PN477219 (order separately)

⚠ WARNING: Use of the wrong grommet can result in leaks, cracked components, shock or fire, and will invalidate approvals and certifications.

2

- Allow extra heating cable for service loop as shown. Not recommended for temperature sensitive fluids or pipes less than 1 in dia.

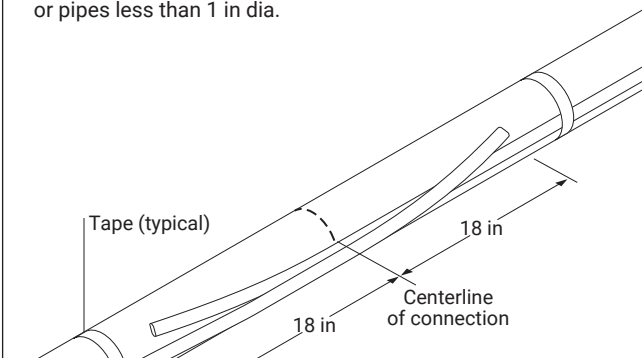

3

- Slide parts onto heating cables.

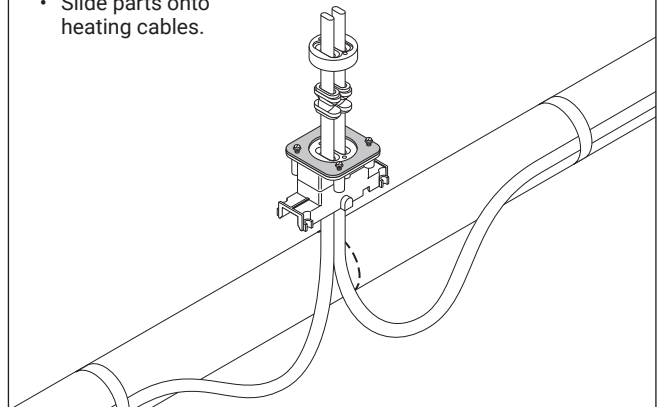

4

- Lightly score outer jacket.
- Bend heating cable to break jacket at score, then peel off outer jacket.

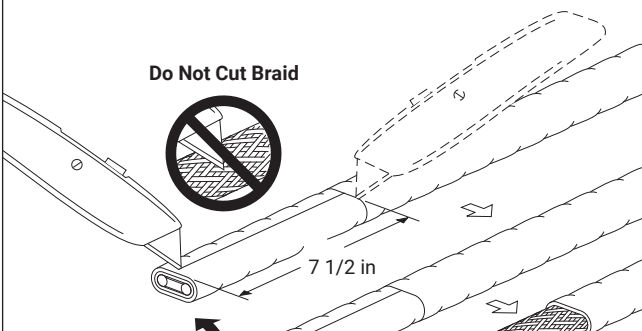

5

- Push braid back to create a pucker.
- Open braid at pucker using screwdriver.

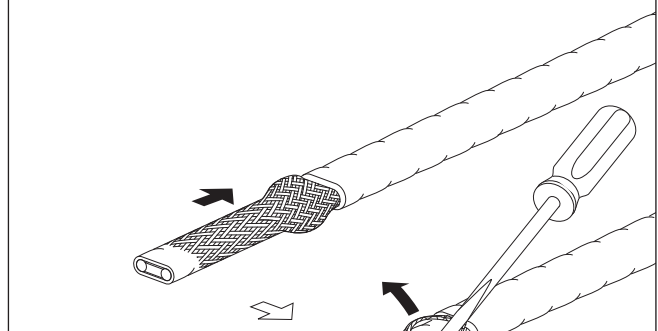

6

- Bend heating cable and work it through opening in braid.
- Pull braid tight.

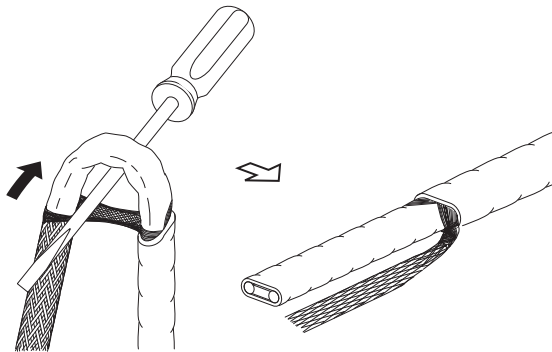

7

- Identify heating cable core type and continue as shown.

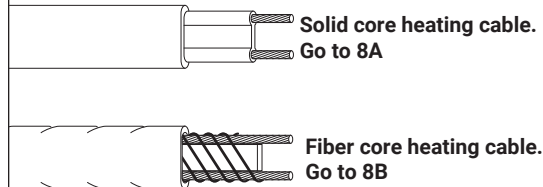

8A Solid core heating cable

- Notch core.
- Twist back and peel bus wire from core.

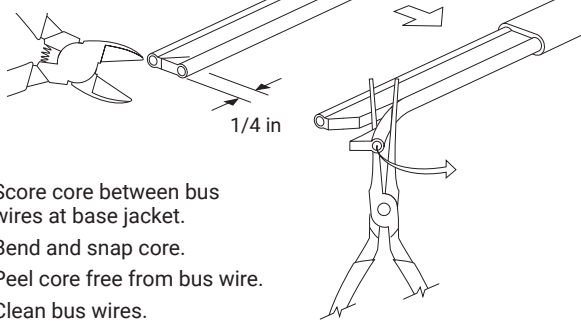

- Score core between bus wires at base jacket.
- Bend and snap core.
- Peel core free from bus wire.
- Clean bus wires.

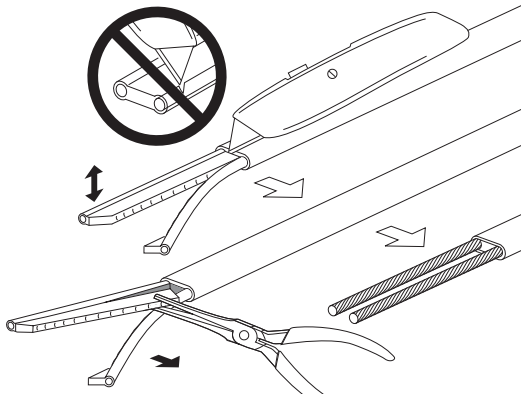

8B Fiber core heating cable

- Cut and remove all fiber strands.

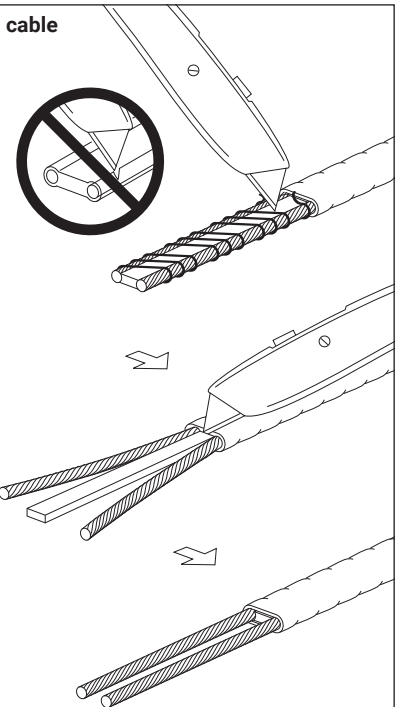

- Score and remove center spacer.

- Clean bus wires.

9

- Slide on heat-shrinkable tubes.
- Use heat gun or mini-torch with soft yellow flame to gently heat tubes until they shrink.

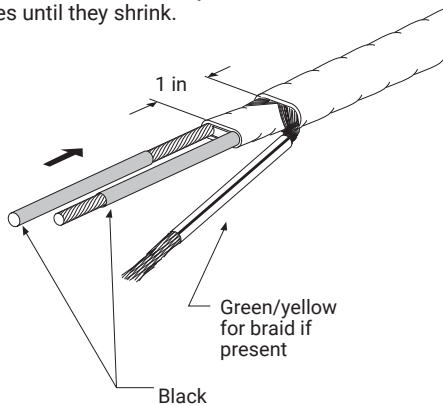

10

- Center clear yellow tubing over end of base jacket.
- Heat tube until it shrinks and adhesive flows out ends. While still hot, pinch between bus wires and hold for 5 seconds to create a seal.
- Trim wire ends.

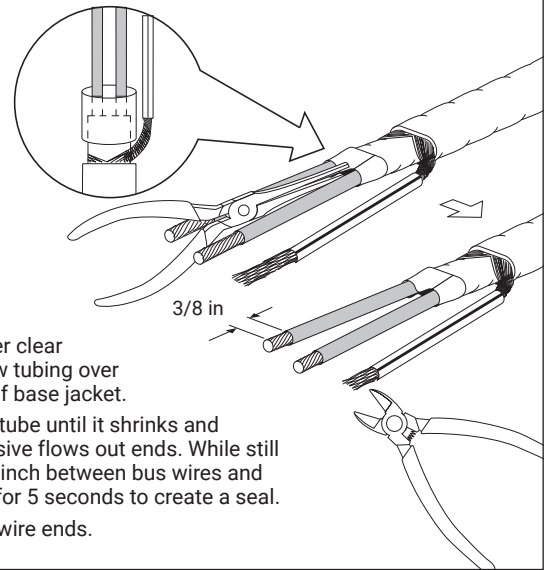

11 For CSA Class I,II, III, Division 2 applications only.

- Apply 3 overlaps of glass tape (RAYCHEM GT-66 or GS-54).

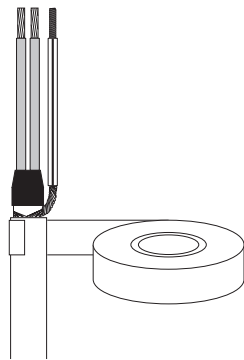

12

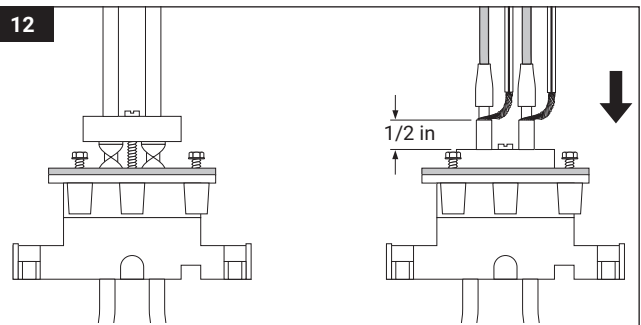

- Start pressure plate screws but do not tighten.
- Pull heating cable thru base and position as shown.
- Tighten screws.

13

- Attach connection box base to pipe with pipe straps. Loop and tape extra heating cable to pipe.

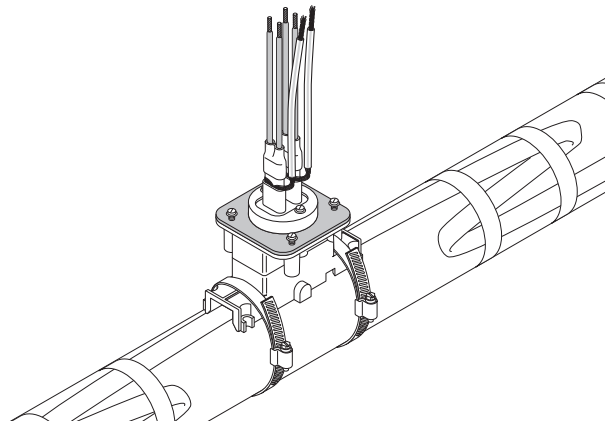

14 For braided heating cable only.

- Trim ground braid to 1/4-inch and crimp on ring terminals.

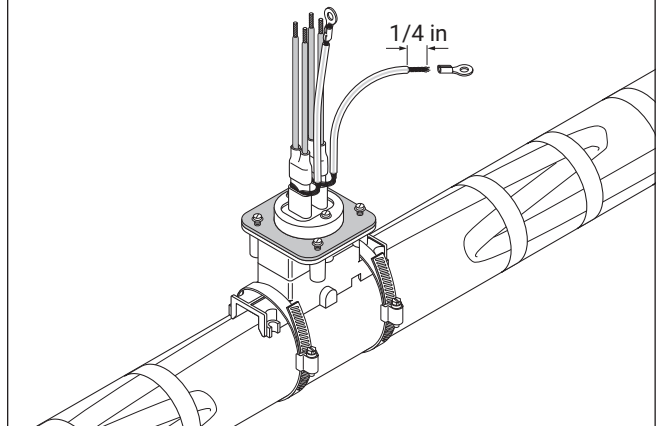

15

- Install junction box over heating cables.
- Tighten screws.

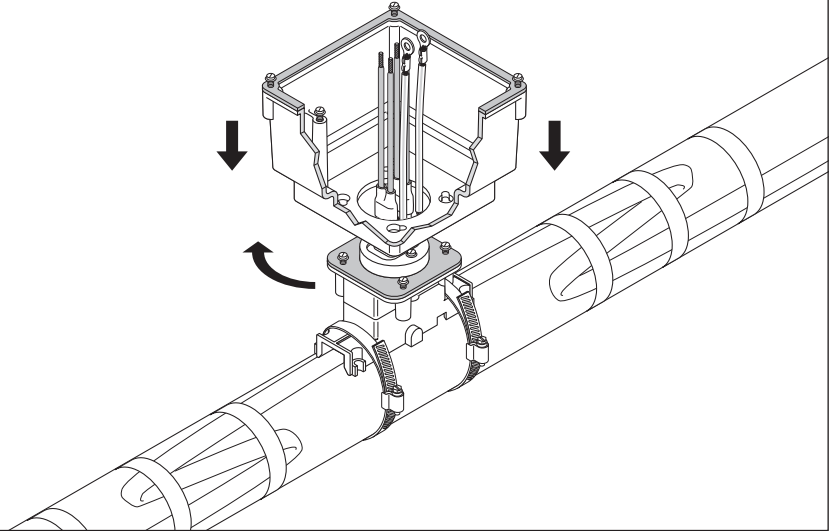

16

- Connect bus wires to terminal block.
- Connect braid wires to grounding post on terminal block bracket.

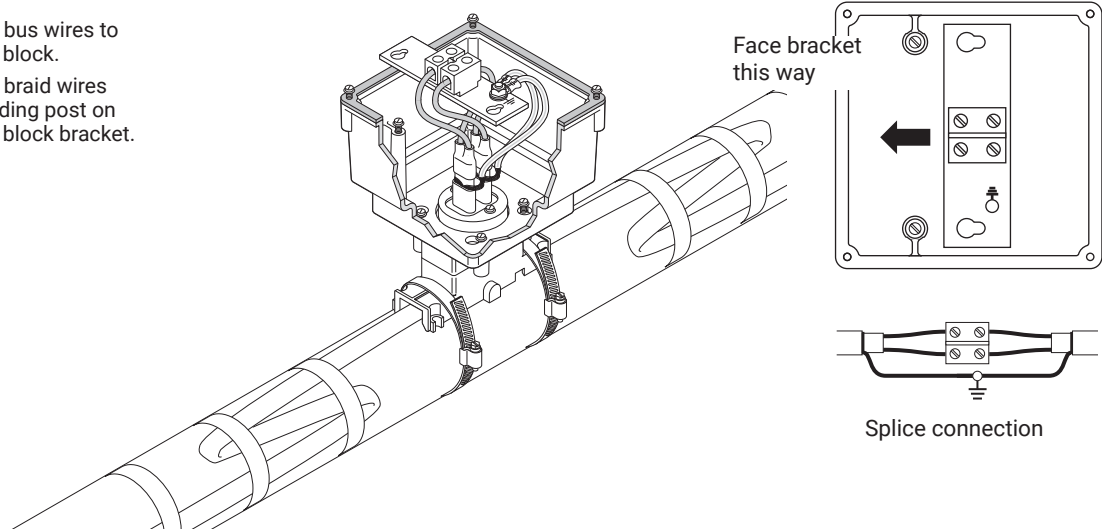

17

- Position terminal block bracket into box. Slide into place and tighten screws.
- Place lid onto box and tighten screws.

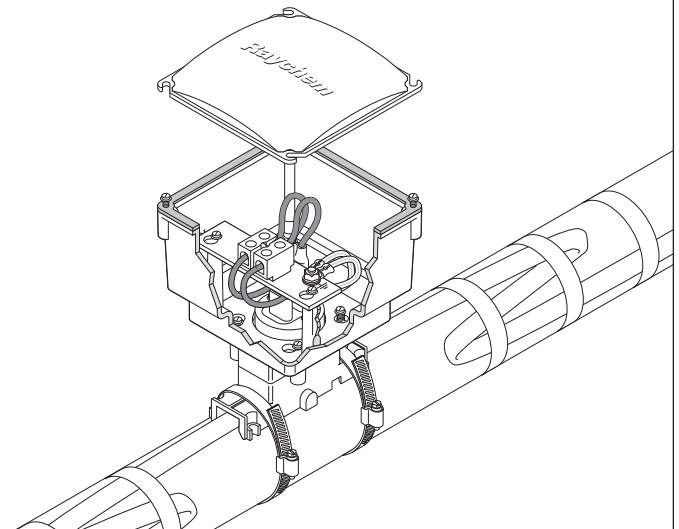

- Installation is complete.

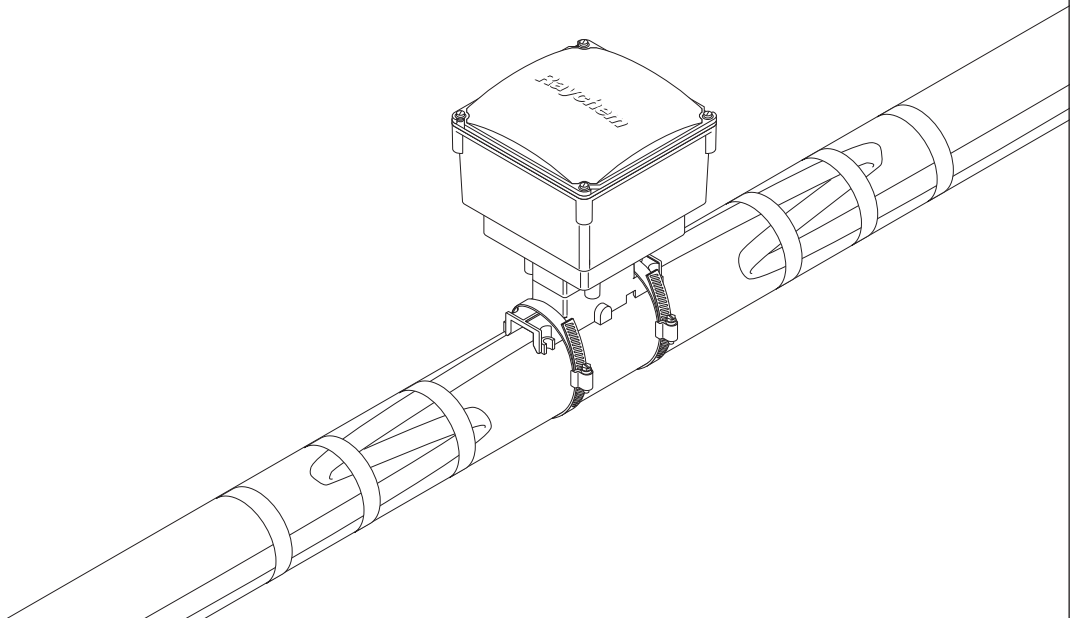

North America

Tel +1 800 545 6258
info@chemelex.com

Latin America

Tel +1 713 868 4800
info@chemelex.com

Europe, Middle East, Africa, India

Tel +32 16 213 511
Fax +32 16 213 604
info@chemelex.com

Asia Pacific

Tel +86 21 2412 1688
infoAPAC@chemelex.com

chemelex
excellence is everything

Raychem

Tracer

Pyrotenax

Nuheat