

# Raychem

## H908

Plug-in Power Connection Kit with End Seal Installation Instructions

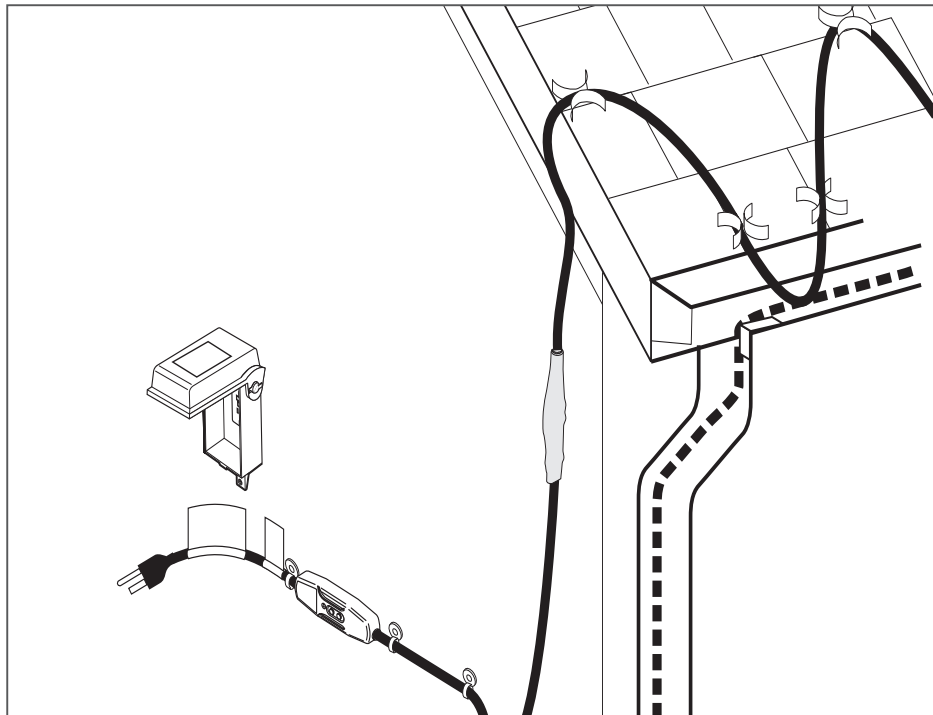

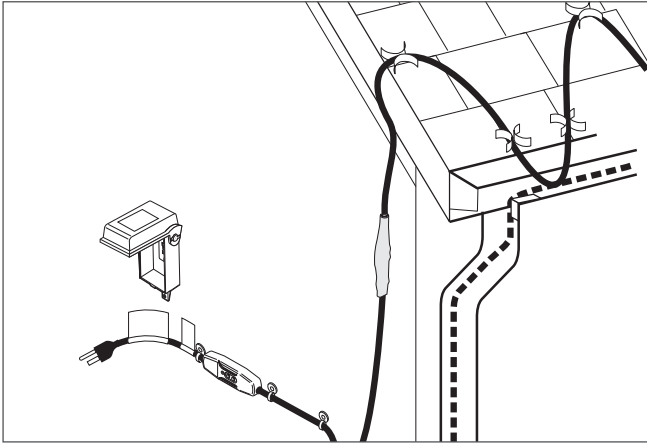

## DESCRIPTION

The Raychem H908 is a plug-in, ground-fault-protected power connection kit for use with Raychem WinterGard H311, Raychem WinterGard Plus H611, and Raychem WinterGard Wet H612 120 V heating cables.

This kit ensures compliance with Chemelex, NEC and CEC requirements for ground-fault protection of equipment. It does not protect people against the hazards of shock. The kit includes materials for one power connection and end seal. All WinterGard, WinterGard Plus, and WinterGard Wet heating cables are designed for water-pipe freeze protection applications. Only the H612 heating cable can be used for both pipe freeze protection and roof and gutter de-icing applications.

For additional technical support call Chemelex at (800) 542-8936.

## TOOLS REQUIRED

- Needle nose pliers
- Propane torch or heat gun
- Utility knife
- Diagonal cutters
- Panduit crimp tools CT100 and CT570

## ADDITIONAL MATERIALS REQUIRED

- Grounded, UL Listed 15-amp, 120-volt receptacle (receptacle must be approved for wet locations if exposed to weather).
- Additional cable ties may be required for roof and gutter applications.
- Your application may require additional Raychem accessories; for example, H903 application tape for pipe applications; H913/H914 roof clips and/or H915 downspout hangers for roof and gutter de-icing applications.

## APPROVALS



718K Pipe Heating System  
877Z De-icing and Snow Melting Equipment

## KIT CONTENTS

Item	Qty	Description
A	1	Plug-in ground-fault equipment protection device
B	2	Black cloth tapes (6 inch long x 1 inch wide)
C	1	Uninsulated braid crimp
D	2	Insulated bus wire crimps
E	2	Heat-shrinkable tubes (1 inch long x 1/8 inch dia.)
F	2	Clamp ties
G	1	Heat-shrinkable tube (8 inch long x 1 inch dia.)
H	2	Warning labels for pipe-trace applications
I	2	De-icing and snow melting equipment labels
J	2	Mastic strips
K	1	Gel-filled end seal
L	1	Heat-shrinkable tube (5 inch long x 3/4 inch dia.)

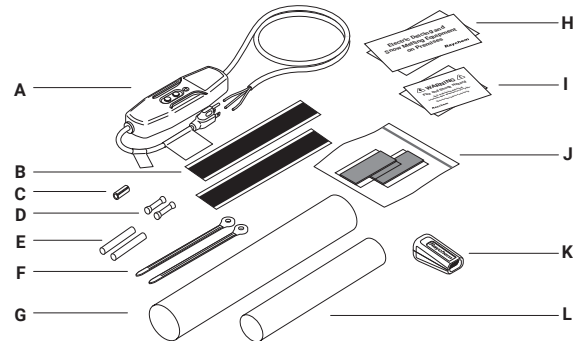

## ⚠ WARNING:

These components are electrical devices. They must be installed correctly to ensure proper operation and to prevent shock or fire. Carefully follow all of the installation instructions and read these important warnings.

- To minimize the danger of fire from sustained electrical arcing if the heating cable is damaged or improperly installed, and to comply with the requirements of Chemelex and the national electrical codes, ground-fault equipment protection must be used on each heating cable branch circuit. Arcing may not be stopped by conventional circuit protection.
- Component approvals and performance are based on the use of specified parts only. Do not substitute parts or use vinyl electrical tape.
- The black heating-cable core is conductive and can short. It must be properly insulated and kept dry.

- Keep components and heating cable ends dry before and during installation.
- Damaged bus wires can overheat or short. Do not break braid or bus wire strands when scoring the jacket or core.
- Bus wires will short if they contact each other. Keep bus wires separated.
- Heat-damaged components can short. Use a heat gun or a torch with a soft, yellow, low-heat flame, not a blue focused flame. Keep the flame moving to avoid overheating, blistering, or charring the heat-shrinkable tubes. Avoid heating other components. Replace any damaged parts.
- Use only fire-resistant insulation materials such as fiberglass wrap.
- Leave these installation instructions with the user for future reference.

## ⚠ CAUTION:

Charring or burning the heat-shrinkable tubes in this kit will produce fumes that may cause eye, skin, nose, and throat irritation. Consult Material Safety Data Sheet RAY3122.

CHEMTREC 24-hour emergency telephone: (800) 424-9300  
Non-emergency health and safety information: (800) 545-6258.

# H908 DESIGN AND INSTALLATION INFORMATION FOR HEATING CABLE ON PIPES ONLY (WINTERGARD H311, WINTERGARD PLUS H611, AND WINTERGARD WET H612 HEATING CABLES)

**Important:** For the Chemelex warranty to be valid, you must comply with all the requirements outlined in these guidelines.

All thermal and design information provided here is based upon a "standard" installation with heating cable fastened to an insulated pipe. For any other application or method of installation, consult Chemelex at (800) 545-6258.

## HEATING CABLE SELECTION AND DESIGN

Make sure that the heating cable being used is suitable for your application. Refer to the Commercial and Residential Application and Design Guide (H53585) for heating cable application information.

### 1. Determine the heating cable type



Use Table 1 to select heating cables for insulated metal pipes. Use Table 2 to select heating cables for insulated plastic pipes. Read across the table to find your pipe size, then drop down to the line corresponding to the lowest air temperature for that application and the correct insulation thickness. The cell at that intersection has a particular shading and may have a number. The shading indicates which heating cable to use (key to the shading appears above the table headings). A number represents the spiraling ratio (feet of heating cable per foot of pipe).

If no number appears in the cell, straight trace the pipe. If a number does appear in the cell, spiral trace the pipe.



If your spiraling ratio is 2.0, multiple trace the pipe using two straight traces at the 4 o'clock and 8 o'clock positions.

If your spiraling ratio is 3.0, multiple trace the pipe using three straight traces at the 11 o'clock or 1 o'clock position, and at the 4 o'clock and 8 o'clock positions.

#### Example 1:

Pipe size: 1 in  
 Lowest air temp.: 0°F  
 Insulation thickness: 1/2 in  
 Metal pipe:  WinterGard H311  
 Plastic pipe:  WinterGard Plus H611, H621  
 WinterGard Wet H612, H622

#### Example 2:

Pipe size: 2 1/2 in  
 Lowest air temp.: -20°F  
 Insulation thickness: 1/2 in  
 Metal pipe:  1.3 WinterGard Plus H611 or WinterGard Wet H612  
 (Use 1.3 feet of heating cable per foot of pipe.)  
 Plastic pipe:  2.0 WinterGard Plus H611 or WinterGard Wet H612  
 (Use two straight traces at the 4 o'clock and 8 o'clock positions.)



**Table 1. For METAL pipes with fiberglass insulation or equivalent (based on 40°F maintain temperature)**

**Key to Table 1:**  = H311  = H611, H612, H621, H622  = Use a thicker insulation

Lowest air temp. (°F)	Insulation thickness	Nominal pipe size									
		1/2 in	3/4 in	1 in	1 1/4 in	1 1/2 in	2 in	2 1/2 in	3 in	4 in	6 in
0	1/2 in									1.3	1.8
	1 in										
	1 1/2 in										
-20	1/2 in						1.1	1.3	1.5	1.8	3.0
	1 in									1.1	1.5
	1 1/2 in										1.1
	2 in										
-40	1/2 in				1.1	1.2	1.4	1.7	2.0	3.0	
	1 in								1.1	1.4	1.9
	1 1/2 in										1.4
	2 in										1.1

**Table 2. For PLASTIC pipes with fiberglass insulation or equivalent (based on 40°F maintain temperature)**

**Key to Table 2:**  = H311  = H611, H612, H621, H622  = Use a thicker insulation

Lowest air temp. (°F)	Insulation thickness	Nominal pipe size									
		1/2 in	3/4 in	1 in	1 1/4 in	1 1/2 in	2 in	2 1/2 in	3 in	4 in	6 in
0	1/2 in						1.2	1.4	1.7	2.0	3.0
	1 in									1.2	1.6
	1 1/2 in										1.2
-20	1/2 in			1.1	1.3	1.5	1.8	2.0	3.0		
	1 in						1.1	1.2	1.4	1.8	3.0
	1 1/2 in								1.1	1.3	1.7
	2 in										1.4
-40	1/2 in	1.1	1.1	1.5	1.8	2.0	3.0	3.0			
	1 in				1.1	1.2	1.4	1.6	1.9	3.0	
	1 1/2 in						1.1	1.2	1.4	1.7	3.0
	2 in								1.1	1.3	1.8

## 2. Calculate the total heating cable length required

$$\text{Length} = A + B + C + D + E + F + G + H$$

- A Pipe length x spiraling ratio
- B 4 ft x # gate/globe valves x valve length (ft) x spiraling ratio
- C 2 ft x # ball/butterfly valves x valve length (ft) x spiraling ratio
- D 2 ft x # flanges x pipe diameter (ft) x spiraling ratio
- E 2 ft x # pipe supports v pipe diameter (ft) x spiraling ratio
- F 1 ft for each power connection
- G 2 ft for each splice connection
- H 3 ft for each tee connection

= Total heating cable length (ft)

## 3. Determine the maximum heating cable circuit length allowed.

See Table 3 on the next page. Ensure that your circuits do not exceed the maximum circuit length listed in Table 3. If necessary, use additional shorter circuits.

**Example** (taken from Example 2 [on metal pipe], page 3):

Pipe length:	50 ft
Spiral ratio:	1.3 (from Table 1, page 3)
Globe valves:	3 (each 0.5 ft long)
Pipe supports:	10 supports for 1 in pipe
Power connections:	1
Splice connections:	1

### WinterGard heating cable required:

A	Pipe length x spiral ratio	= 50 ft x 1.3	= 65.0 ft
B	3 globe valves (0.5 ft each)	= 4 ft x 3 x 0.5 x 1.3	= 7.8 ft
C	0 ball/butterfly valves	= 0	= 0
D	0 flanges	= 0	= 0
E	10 pipe supports	= 2 ft x 10 x 0.085* x 1.3	= 2.2 ft
F	1 power connection	= 1 ft x 1	= 1.0 ft
G	1 splice connection	= 2 ft x 1	= 2.0 ft
H	0 tee connection	= 0	= 0

**Total heating cable length required = 78.0 ft**

\*1 in pipe diameter / 12 in per foot = 0.085 foot

## HEATING CABLE INSTALLATION

### 1. Prepare for installation

- Store the heating cable in a clean, dry place.
- Complete piping pressure test.
- Review the WinterGard heating cable design and compare to materials received to verify that the proper WinterGard heating cable and accessories are available. The WinterGard heating cable will have the heating cable type printed on the outer jacket.
- Walk the system and plan the routing of the WinterGard heating cable on the pipe.

### 2. Cut the heating cable to length

- Cut the heating cable to the length required. This can be done before or after the cable is attached to the pipe. Leave a minimum of 1 foot extra heating cable for connection to power. For splice and tee connections, leave a minimum of 1 foot for each section of heating cable. WinterGard heating cable can be cut to length without affecting its heat output per foot.
- Protect the heating cable ends from moisture or mechanical damage if they will be left exposed before connection.

### 3. Position and attach heating cable to pipe

- Be sure all piping to be traced is dry.
- Install heating cable, using straight tracing, spiraling, or multiple tracing according to the "Heating cable selection and design" section on page 2.
- For straight tracing, install the heating cable on a lower half of the pipe; for example, in the 4 o'clock or 8 o'clock position.
- Be sure to install the additional heating cable required for valves, flanges, etc. as indicated in Step 2 of the "Heating cable selection and design" section.
- When the design calls for spiraling, begin by suspending a loop every 10 feet as shown in Figure 1. To determine the loop length, obtain the spiral factor from Table 1 or 2 and multiply by 10. For example, if a spiral factor of 1.3 is called for, leave a 13-foot loop of heating cable at every 10-foot section of pipe. Grasp the loop in its center and wrap it around the pipe. Even out the distance between spirals by sliding the wraps along the pipe. Use glass tape to secure the center of the loop to the pipe. Secure the heating cable flat to the pipe to obtain good contact.
- Tape WinterGard heating cable to the pipe at 2-foot intervals using Raychem H903 fiberglass application tape or nylon cable ties. Do not use vinyl electrical tape, duct tape, metal bands, or wire.

### 4. Install heating cable end seals, splices, tees, and power connection

- Test each circuit before installing the H908 ground-fault device, according to the instructions in the "Heating cable testing and maintenance" section.
- Install all end seals, splices, tees, and power connection prior to plugging in.
- Follow the H908 kit installation instructions beginning on page 8.
- Use only weatherproof receptacles approved for wet locations when installing WinterGard Wet H612 heating cable with the H908 Power Connection Kit for Roof and Gutter De-Icing Applications.

### 5. Check the installation

- Prior to installing thermal insulation, make sure the heating cable is free of mechanical damage (from cuts, clamps, etc.) and thermal damage (from solder, overheating, etc.).
- Visually check all power connections, end seals, splices, and tees.
- Using a megohmmeter, test each circuit according to the instructions in the "Heating cable testing and maintenance" section (page 4) both before and after installing the thermal insulation.

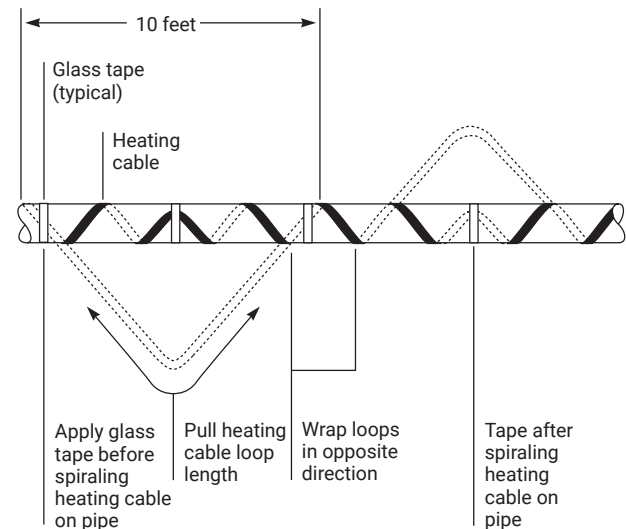

Figure 1. Spiraled heat tracing

## 6. Install thermal insulation

- A reliable heat-tracing system depends on properly installed and weather-proofed thermal insulation.
- Ensure that type and thickness of the insulation are in accordance with the information in the heating cable selection tables on page 2 and that all pipe work—including valves, joints, wall penetrations, and other elements—has been fully insulated.
- Minimize the potential for mechanical damage to the heating cable after installation by installing the insulation immediately.

## 7. Mark the installation

- Place “Warning” labels for pipe trace applications on the outer surface of the insulation at 10-foot intervals (on alternating sides of the pipe) to indicate the presence of WinterGard electric heating cable. Additional labels and application tape are contained in the H903 kit.

## 8. Check the installation

- Prior to powering, check to be sure the heating cable is free of mechanical damage (cuts, clamps, etc.).
- Visually check all power connections, end seals, splices, and tees for proper installation.

## 9. Test the ground-fault protection

- Verify the H908 ground-fault device is functioning correctly, according to the instructions in the “Heating cable testing and maintenance” section.

## ELECTRICAL PROTECTION

For the maximum heating cable circuit length permitted for a given circuit breaker rating, refer to Table 3. Limit your circuit length based on your lowest anticipated start-up temperature.

The H908 kit contains a built-in 27-mA equipment-protection ground-fault device. This kit provides ground-fault protection of equipment only. It does not protect people against the hazards of electrical shock.

Do not use an extension cord. Plug the unit directly into the outlet.

**Note:** Chemelex, Article 427 of the NEC and Part I, Section 62 of the CEC require ground-fault protection for pipe heating cable applications.

**Table 3. Maximum heating cable circuit length on pipe**

Heating cable type	Circuit breaker rating (A)	Maximum heater length (ft) per circuit at start-up temperature	
		0°F	40°F
WinterGard 120 V H311 on pipe	15	150	250
WinterGard Plus 120 V H611 on pipe	15	125	150
WinterGard Wet 120 V H612 on pipe	15	125	150

**Note:** Circuit breaker sizing is based on Section 427-4 of the National Electrical Code. Maximum circuit lengths are based on start-up load. Steady-state amps per foot is dependent upon heating cable temperature..

## HEATING CABLE TESTING AND MAINTENANCE

Using a 2500-Vdc megohmmeter (Megger) test the heating cable circuit prior to installing the H908 ground-fault device but after installing any splices, tees and end seals. Measure the insulation resistance between the heating cable bus wires and the copper braid. If the readings are less than 1000 megohms, inspect heating cables for signs of damage and verify the components are correctly installed.

If physical damage is found, the entire damaged section must be removed and a new section of heating cable spliced in using only approved H910 splice kits.

If physical damage cannot be found, the complete circuit should be removed and replaced with new heating cable.

To verify the ground-fault circuit is functioning, test the H908 before

each use. Push in the test button. The indicator light must turn off. Then press the reset button. If the light goes back on, the device is ready to use. Do not use the device if the indicator light does not go on when the device is reset or if the indicator light remains on when the test button is pushed.

Test the H908 functionality before each winter season or more often as required by local code.

**⚠ WARNING: Shock and Fire Hazard. Damaged heating cable or components can cause electrical shock, arcing, and fire. Do not attempt to energize damaged cable or components. Replace them immediately using a new length of heating cable and the appropriate WinterGard accessories.**

**Table 4. Product data—WinterGard products on pipe only**

Heating cable type	WinterGard	WinterGard Plus	WinterGard Wet
	H311	H611	H612
Service voltage (V)	120	120	120
Thermal output at 40°F (W/ft)	3	6	6
Weight per 100 ft (lb)	6	6	9
Minimum installation temp. (°F)	0	0	0
Maximum exposure temp. (°F)	150	150	150
Exposure to chemicals	None	None	None
Environment	Use only in dry ordinary (nonhazardous) areas.	Use only in dry ordinary (nonhazardous) areas.	Use only in wet or dry ordinary (nonhazardous) areas.

## H908 DESIGN AND INSTALLATION INFORMATION FOR ROOF AND GUTTER DE-ICING ONLY (WinterGard Wet H612 Heating Cable)

**Important:** For the Chemelex warranty to be valid, you must comply with all the requirements outlined in these guidelines.

All design information provided here is based on a “standard” shake or shingle roof application. For any other application or method of installation, consult Chemelex at (800) 545-6258.

### HEATING CABLE DESIGN

Only WinterGard Wet H612 120 V heating cable is suitable for use with the H908 power connection kit for roof and gutter de-icing applications.

#### 1. Calculate the heating cable length required.

$$\text{Length} = \text{A} + \text{B} + \text{C} + \text{D} + \text{E} + \text{F} + \text{G}$$

- A** Roof edge length (ft) x feet of heating cable per foot of roof edge (From Table 5)
- B** Roof edge length (ft) x 0.5\*
- C** Total gutter length (ft)
- D** Total downspout length (ft) + 1 (ft)
- E** 1 ft for each power connection
- F** 2 ft for each splice connection
- G** 3 ft for each tee connection

**= Total heating cable length (ft)**

\* Roof extension: This length allows the heating cable to extend into the gutter to provide a continuous drain path, or where no gutters are present, extends beyond the roof edge to form a drip loop.

**Table 5. WinterGard Wet cable length for roof de-icing**

Eave overhang	Shingle roof	Standing seam metal roof:	
		18 inch seam	24 inch seam
0	2.0 ft	2.5 ft	2.0 ft
12 in	2.8 ft	2.8 ft	2.4 ft
24 in	3.8 ft	3.6 ft	2.9 ft
36 in	4.8 ft	4.3 ft	3.6 ft

**Note:** Chemelex recommends a gutter and downspouts to provide a continuous path for melted water.

Example:

Roof edge:	20 ft	<b>A</b> Roof edge:	20 ft x 2.0 (from Table 5) = 40 ft
Roof overhang:	1 ft	<b>B</b> Roof extension:	20 ft x 0.5 = 10 ft
Roof gutter:	20 ft	<b>C</b> Roof gutter:	= 20 ft
Downspout:	15 ft	<b>D</b> Downspout:	= 15 ft + 1 ft = 16 ft
Power connection:	1 ea	<b>E</b> Power connection:	1 ft x 1 ea = 1 ft
Tee connection:	1 ea	<b>F</b> Splice connection:	= 0
Voltage available:	120 V	<b>G</b> Tee connection:	3 ft x 1 ea = 3 ft
CB Size Available:	15 A	<b>Total WinterGard Wet heating cable required:</b>	<b>90 ft**</b>
Start-up temperature:	0 °F	**This total is less than 100-ft maximum circuit length (see Table 6), therefore a single circuit is required	

### HEATING CABLE INSTALLATION

#### 1. Prepare for installation.

- Store the heating cable in a clean, dry place.
- Use only the following Raychem accessories to satisfy code and agency requirements:
  - H908 Plug-in Power Connection Kit (with end seal)
  - H910 Splice and Tee Kit (if splicing or teeing)
  - H915 Downspout Hangers
  - H913/H914 Roof Clips
- Carefully plan the routing of the heating cable for roof and gutter de-icing.
- Make certain gutters and downspouts are free of leaves and other debris.

#### 2. Cut the heating cable to length.

- Cut the heating cable to the length required before or after it is installed. Leave a minimum of 1 foot extra heating cable for connection to power. For splice and tee connections leave a minimum of 1 foot for each section of heating cable. WinterGard heating cable can be cut to length without affecting its heat output per foot.
- Protect the heating cable ends from moisture and mechanical damage if they will be left exposed before connection.

#### 3. Position and attach the heating cable.

##### On roofs

- Loop the heating cable on the overhang area of the roof. This is the part that extends past the building wall. Extend the bottom of each heating cable loop over the roof edge and, using a UV-resistant cable tie, connect the bottom of each loop to the cable running in the gutter to ensure a drainage channel off the roof and into the gutter and downspout. The cable running in the gutter should remain against the bottom of the gutter. Extend the top of each heating cable loop beyond where the wall joins the roof. Chemelex recommends 2-foot clip-spacing along the roof edge. See the “Heating cable design” section (Table 5) for spacing and layout information.

- Use WinterGard H913/H914 roof clips to attach heating cable to the roof surface. One kit contains ten double roof clips for approximately 7 linear feet of roof edge. One H914 kit contains 50 roof clips for approximately 35 linear feet of roof edge. For flat roofs, the heating cable can be spaced as needed to create runoff paths for melting ice and snow. Use single-ended clips located at 3-foot intervals to secure the cable to the roof. Roof clips may be attached to a shake or shingle roof with nails or screws. Roof clips may be attached to a metal roof using screw, nail or adhesive. (See H56723 installation instruction for more details.) Reseal the nail or screw holes if necessary before installing heating cable in the clips.
- A barrier (snow fence) can be placed on the roof above the heating cable. This prevents damage to the cable and keeps the installation from coming loose due to ice slides. The heating cable can be attached to the barrier with UV-resistant cable ties, instead of using roof clips, if desired. Do not use wire or other materials because they may damage the heating cable.

##### In gutters and downspouts

- Run heating cable along gutters and into downspouts, ending below the freezing level. Permanent attachment of the cable to the gutter bottom is not necessary. Loop the heating cable in downspouts if convenient, such as when the downspout is not at the end of the run, or use the H910 splice and tee kit to tee down the downspout.
- Use WinterGard H915 downspout hangers to protect the heating cable from fraying and from damage from sharp edges and to provide strain relief. Refer to the H915 kit instructions for installation details.
- Use WinterGard H913/H914 roof clips to route heating cable into and out of the gutter in such a way as to prevent abrasion to the cable. Protect all cable that protrudes past the lower opening of the downspout.

#### 4. Install heating cable end seals, splices, tees, and power connection

- Using a megohmmeter, test each circuit before installing the H908 ground-fault device, according to the instructions in the “Heating cable testing and maintenance” section.
- Install all end seals, splices, tees, and power connection prior to plugging in.
- Follow the H908 kit installation instructions beginning on page 8.
- Use only weatherproof receptacles approved for wet locations when installing WinterGard Wet H612 heating cable with the H908 Power Connection Kit for Roof and Gutter De-Icing Applications.

#### 5. Mark the installation

- Two labels indicating the presence of electric de-icing and snow-melting equipment on the premises are included with this

unit. One label must be posted at the electrical outlet cover. The other label must be posted at the fuse or circuit breaker panel. The labels must be clearly visible.

#### 6. Check the installation

- Prior to powering, check to be sure the heating cable is free of mechanical damage (cuts, clamps, etc.).
- Visually check all power connections, end seals, splices, and tees for proper installation.

#### 7. Test the ground-fault protection

- Verify the H908 ground-fault device is functioning correctly, according to the instructions in the “Heating cable testing and maintenance” section.
- Using a megohmmeter, test each circuit according to the instructions in the “Heating cable testing and maintenance” section (page 4) both before and after installing the thermal insulation.

### ELECTRICAL PROTECTION

#### Voltage rating

H612	110–120 Vac
------	-------------

#### Ground fault protection:

The H908 plug contains a built-in 27-mA equipment-protection ground-fault device. This kit provides ground-fault protection of equipment only. It does not protect people against the hazards of electrical shock.

Do not use an extension cord. Plug the unit directly into the outlet.

Note: Chemelex and the national electrical codes require ground-fault protection of equipment for de-icing systems.

**Table 6. Maximum heating cable circuit length for roof and gutter de-icing, downspouts and refrigeration condensate drains**

Heating cable type	Circuit breaker rating (A)	Maximum heater length (ft) per circuit at start-up temperature	
		0°F	32°F
WinterGard Wet 120 V H612 in downspout and refrigeration condensate drains	15	100	125

Note: Maximum circuit lengths are based on start-up load. Steady-state amps per foot is dependent upon heating cable temperature.

### HEATING CABLE TESTING AND MAINTENANCE

Make sure that gutter and downspouts are free of leaves and other debris prior to the winter season.

Using a 2500-Vdc megohmmeter (Megger) test the WinterGard Wet heating cable circuit prior to installing the H908 ground-fault device but after installing any splices, tees and end seals. Measure the insulation resistance between the heating cable bus wires and the copper braid. If the readings are less than 1000 megohms, inspect heating cables for signs of damage and verify the components are correctly installed.

If physical damage is found, the entire damaged section must be removed and a new section of heating cable spliced in using only approved H910 splice kits.

If physical damage cannot be found, the complete circuit should be removed and replaced with new heating cable.

To verify the ground-fault circuit is functioning, test the H908 before each use. Push in the test button. The indicator light must turn off. Then press the reset button. If the light goes back on, the device is ready to use. Do not use the device if the indicator light does not go on when the device is reset or if the indicator light remains on when the test button is pushed.

Test the H908 functionality before each winter season or more often as required by local code.



**WARNING: Shock and Fire Hazard. Damaged heating cable or components can cause electrical shock, arcing, and fire. Do not attempt to energize damaged cable or components. Replace them immediately using a new length of heating cable and the appropriate WinterGard accessories.**

**Table 7. Product data—WinterGard Wet H612 for roof and gutter de-icing only**

Service voltage (V)	120
Thermal output at 32°F (W/ft) (in ice and snow)	8
Weight per 100 ft (lb)	9
Minimum installation temp. (°F)	0
Maximum exposure temp. (°F)	150
Exposure to chemicals	None
Environment	Use only in ordinary (nonhazardous) areas.

**Note:**

- In all locations, route and secure cable to avoid possible mechanical damage, such as from ladders, etc.
- Neither the ground-fault unit nor the power connection splice can be submerged.

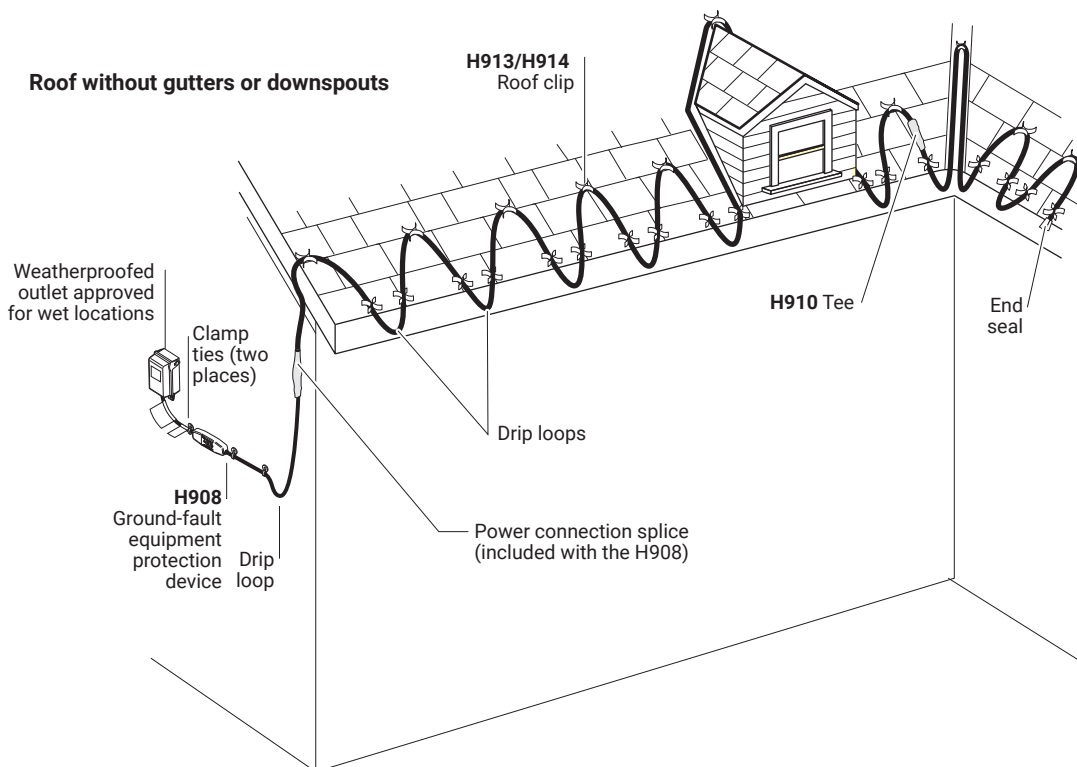
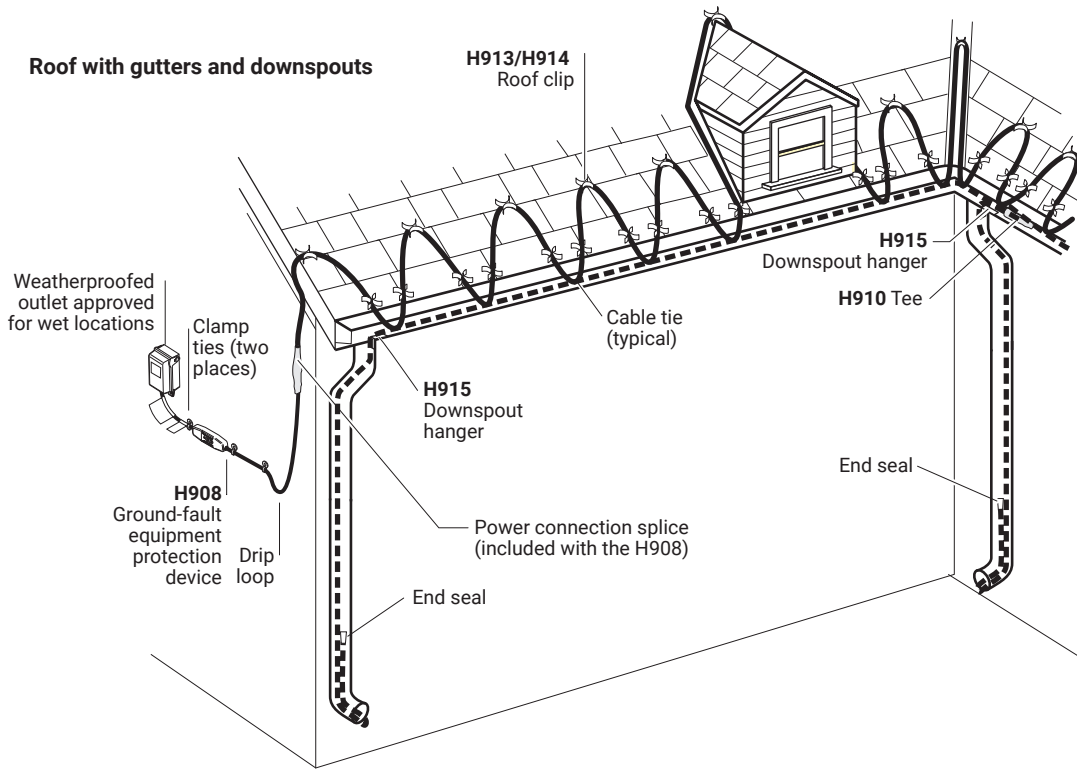

# H908 POWER CONNECTION KIT

## Identify heating cable

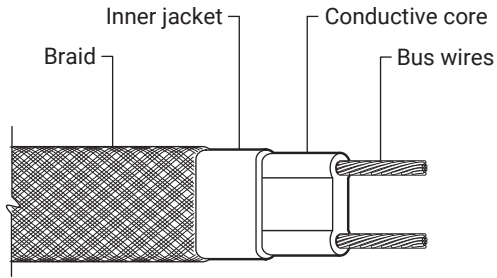

**WinterGard H311 and WinterGard Plus H611**  
Heating cables with braid and no outer jacket

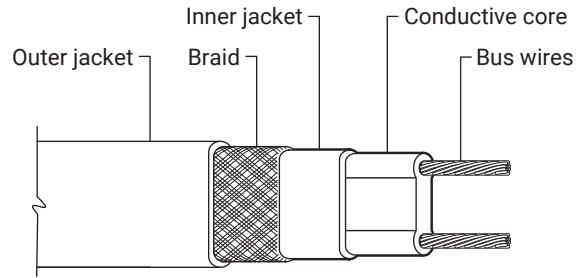

**WinterGard Wet H612**  
Heating cables with braid and outer jacket

**Note:** Instructions generally show heating cable with braid and outer jacket. Cables with no outer jacket look slightly different from those illustrated.

## Stripped end of ground-fault protection device

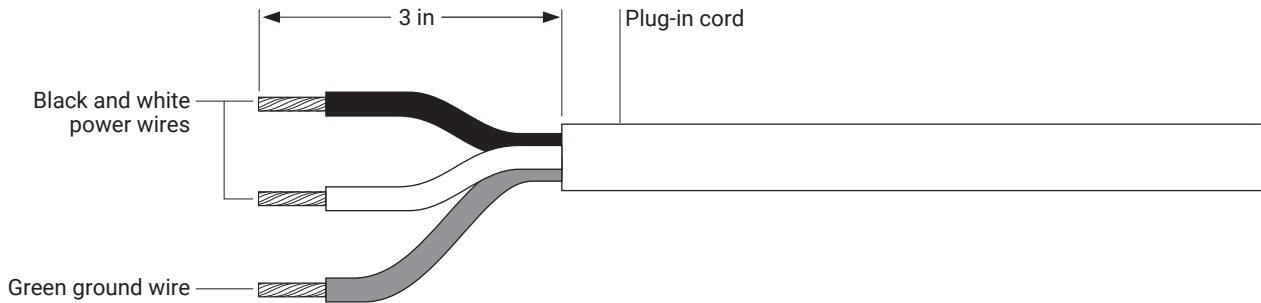

### 1 For all heating cables

- Slide 8-inch tube and 5-inch tube over end of the plug-in cord.

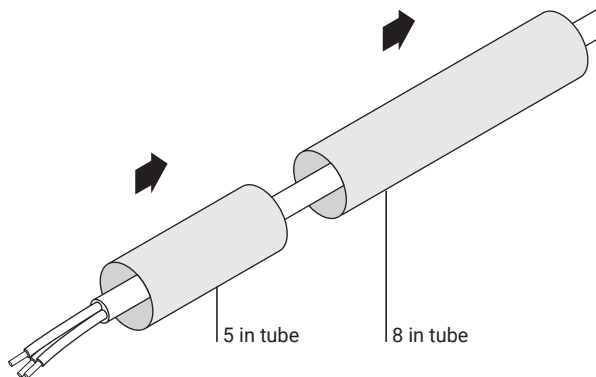

### 2A For H311 and H611 heating cables only

- Unravel 2 3/4 inches of braid.
- Straighten the braid and twist into a pigtail.

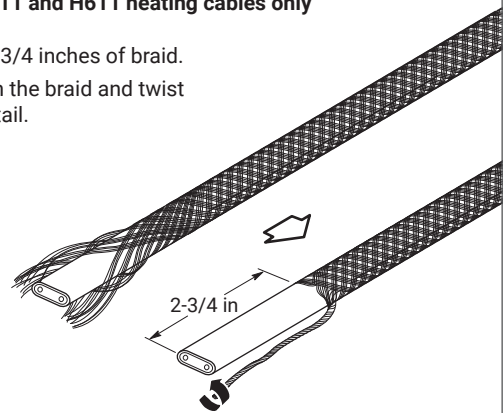

**2B For H612 heating cable only**

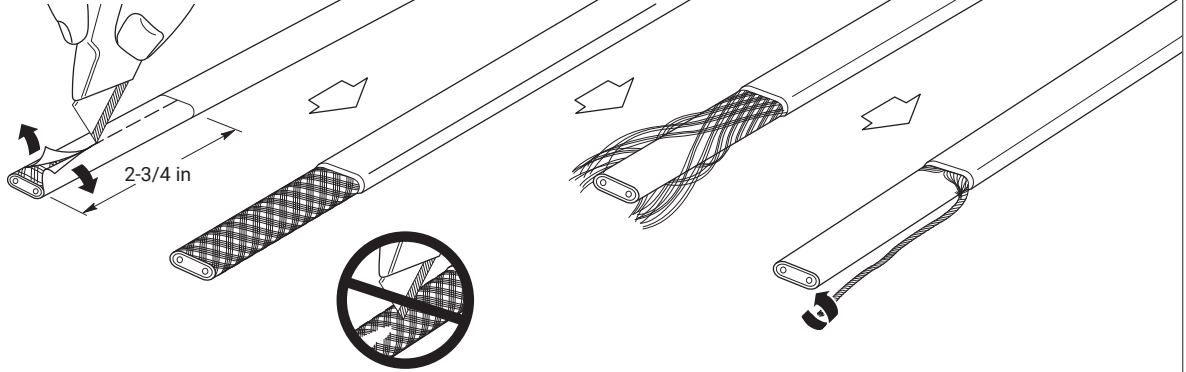

**Do not cut braid or inner jacket.**

- Lightly score completely around and then down outer jacket.
- Unravel the braid back to the outer jacket.
- Straighten the braid and twist into a pigtail.

**3 Remove inner jacket (H612 cable shown)**

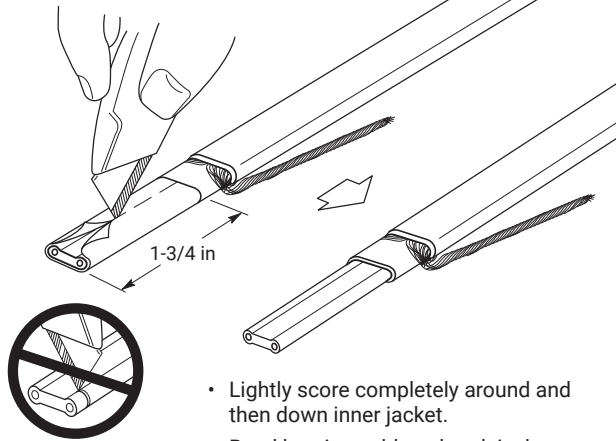

**Do not cut bus wires.**

- Lightly score completely around and then down inner jacket.
- Bend heating cable to break jacket at score, then peel off inner jacket.

**4 Expose bus wires**

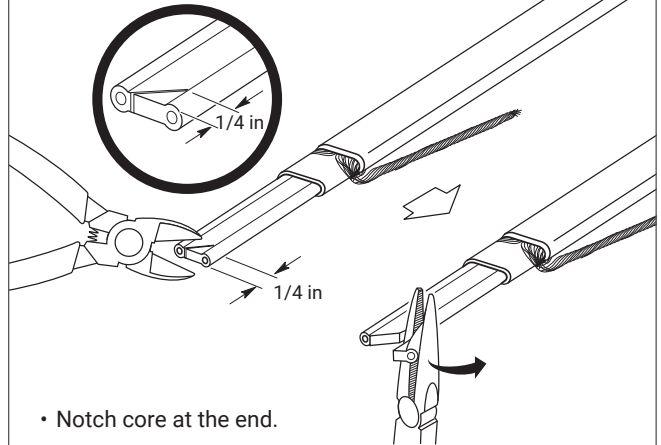

- Notch core at the end.
- Twist back and peel bus wires from core.

**5 Expose bus wires (continued)**

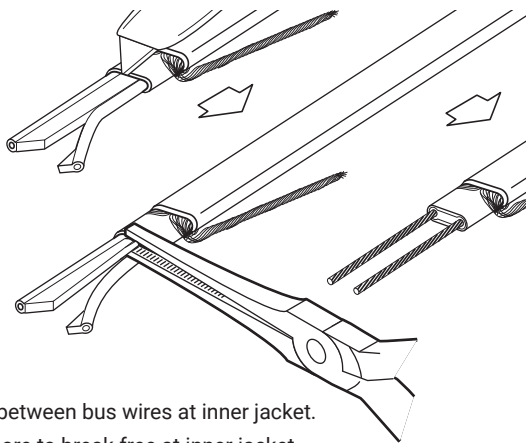

- Score between bus wires at inner jacket.
- Bend core to break free at inner jacket.
- Peel core and any remaining material from bus wires.

**6 Prepare bus wires**

- Slide 1/8 inch x 1 inch shrink tubes over bus wires.
- To shrink tubing move heat source continuously from side to side.
- While shrinking, ensure that tubes remain up against black core.
- Trim bus wires.

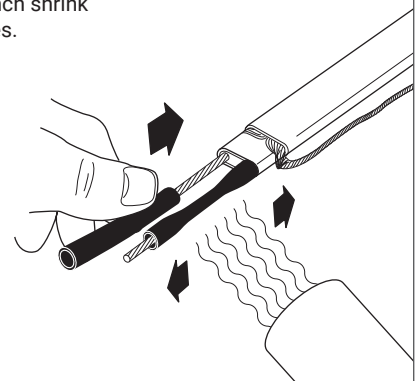

**CAUTION: Health Hazard**  
Consult material safety datasheet RAY3122.

## 7 Finish bus wire preparation

- Trim bus wires.

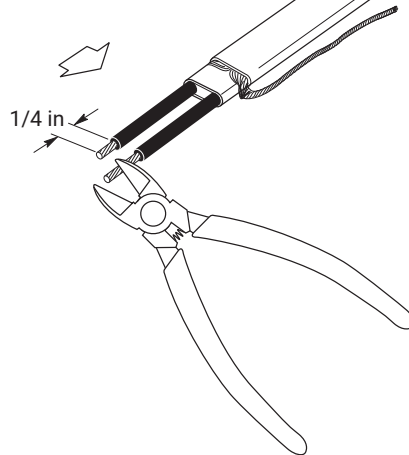

## 8 Connect bus wires

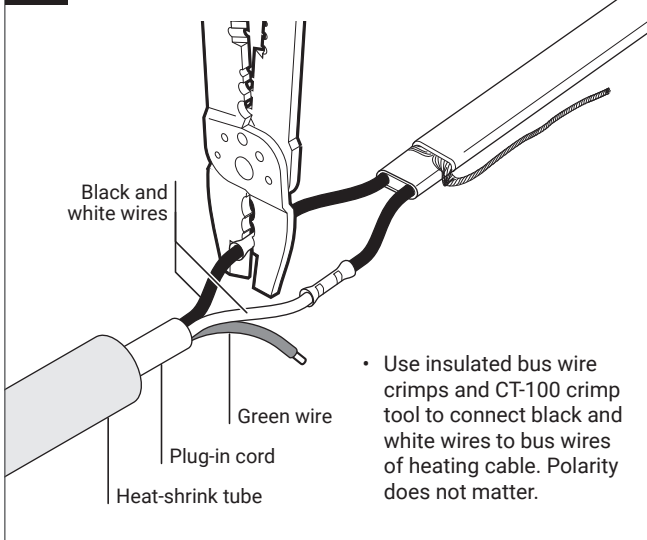

## 9 Apply mastic to bus wires

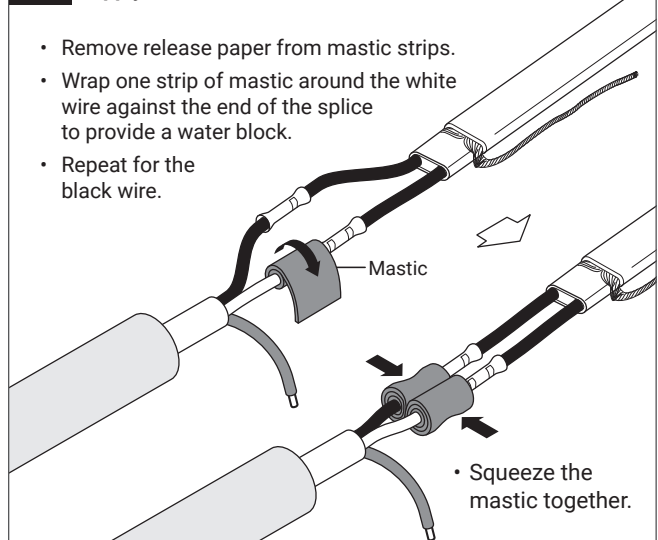

## 10 Apply 5-inch shrink tube

- Center the 5-inch heat-shrinkable tube over the splice. Make sure tube extends over the end of each heating cable and the cord.
- Shrink the tube completely. Start at the middle and work toward each end. Keep heating after tube has shrunk, to melt mastic and adhesive inside tube. Total heating time should be about 2 minutes.

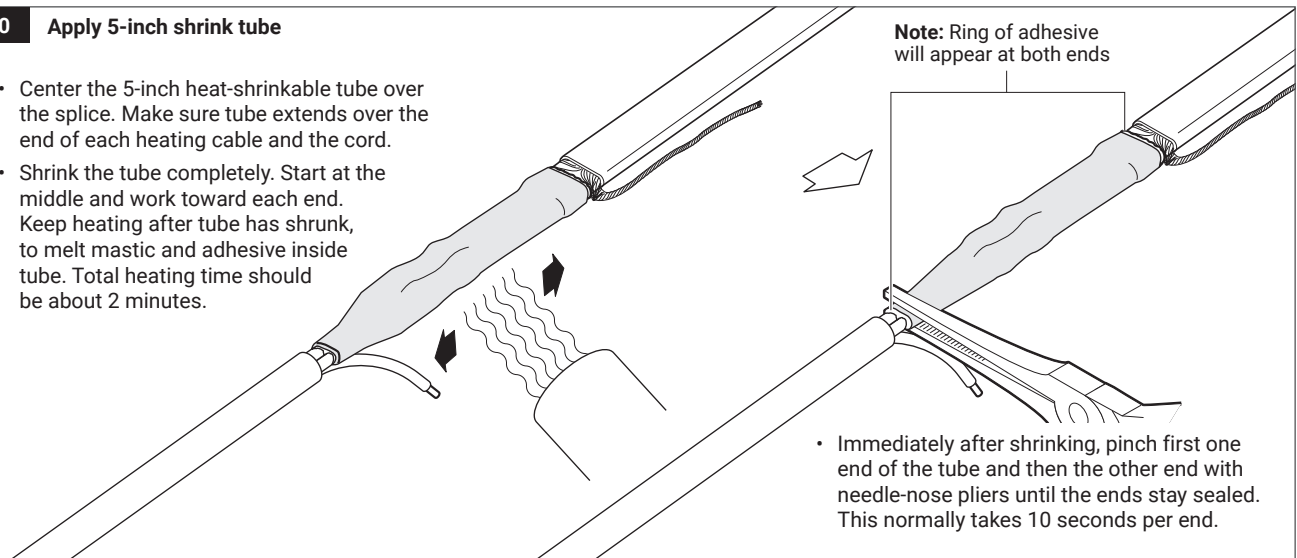

### 11 Connect ground wire

- Use uninsulated braid crimp and CT-570 crimp tool to connect braid to ground wire.
- Wrap black cloth tape evenly around crimp and splice.
- Cover crimp completely.

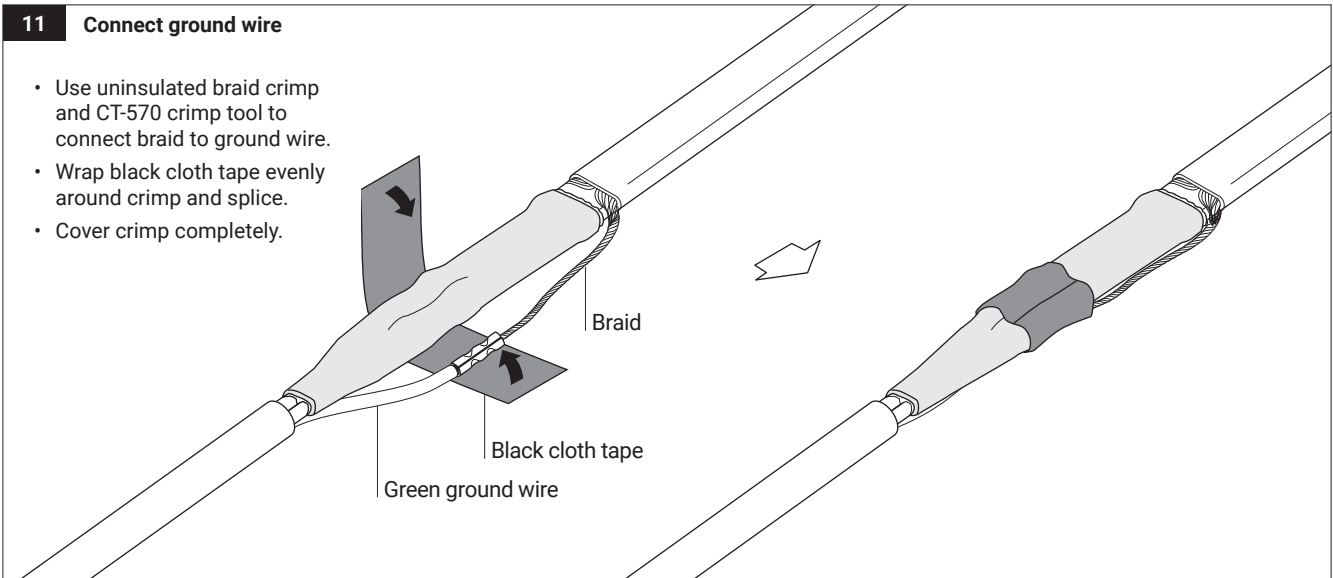

### 12 Apply 8-inch shrink tube

- Center the 8-inch heat-shrinkable tube over the splice. Make sure that the tube extends over the end of the heating cable and cord.
- Shrink the tube completely. Start at the middle and work toward each end. Keep heating after tube has shrunk, to melt adhesive inside tube. Total heating time should be about 3 minutes.

**Note:** Ring of adhesive will appear at both ends

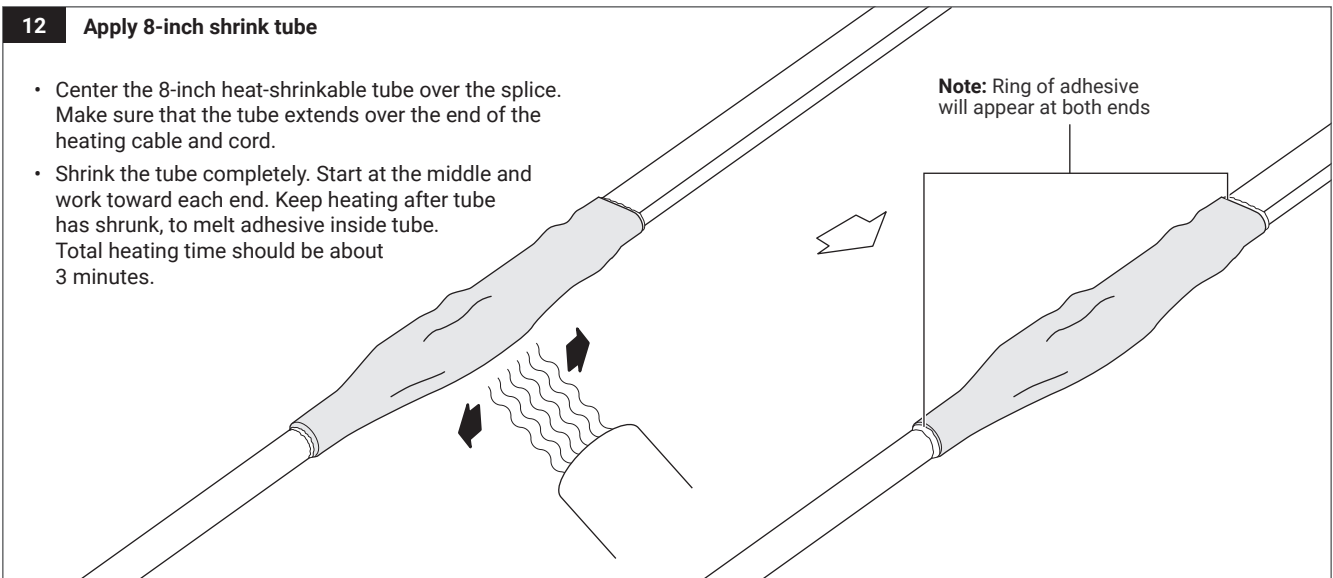

## H908 END SEAL

**Note:** The end seal is designed to be installed only once; it cannot be removed from the heating cable once installed. Do not use until ready for final installation.

### 1A End Seal for H612

- Cleanly cut off the end of the cable.
- Score down and around outer jacket 1 inch from the end.
- Remove the outer jacket.
- Do not cut or damage inner jacket.

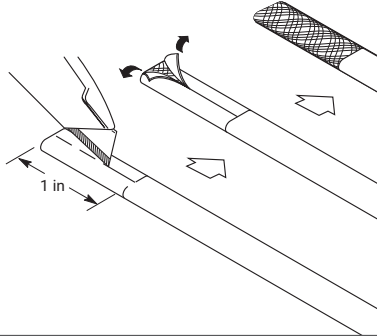

### 1B End Seal for H311, H611

- Cleanly cut off the end of the cable.

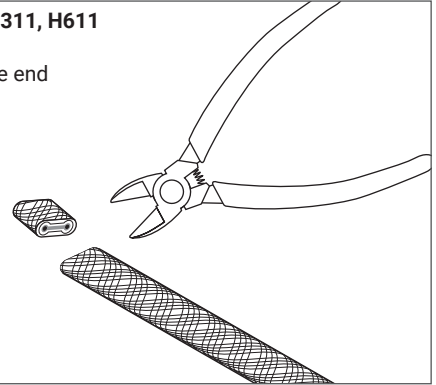

### 2A

- Unravel and remove exposed braid.

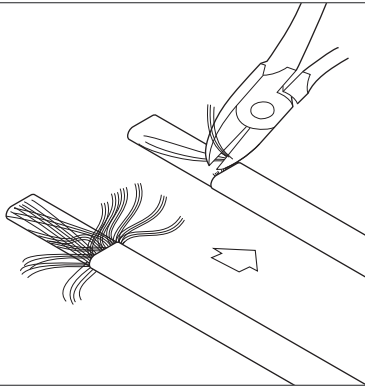

### 2B

- Push the braid back 2 inches from the cable end.

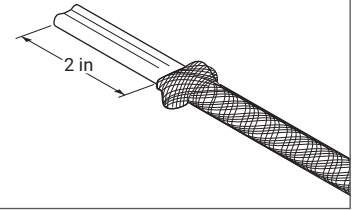

### 3A

- Firmly push end seal onto the cable (at least 1 1/2 inches). Some gel may ooze out.
- Do not twist or try to remove the end seal during or after insertion. Do not reuse an end seal.

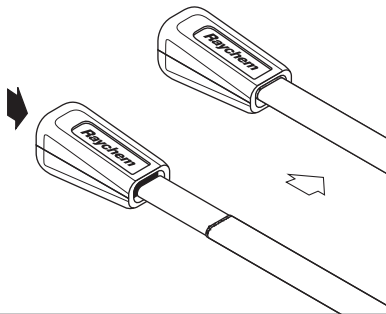

### 3B

- Firmly push end seal onto the cable (at least 1 1/2 inches). Some gel may ooze out.
- Do not twist or try to remove the end seal during or after insertion. Do not reuse an end seal.

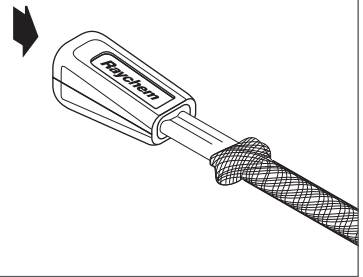

### 4B

- Slide the braid up against the end seal and secure with the 6-inch length of tape provided.

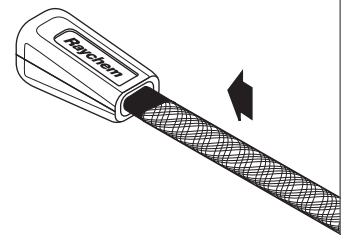

## Securing the Ground-Fault Device

### 1A For pipe freeze protection

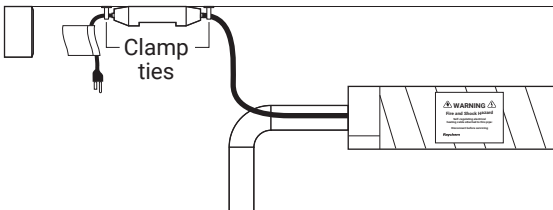

- To prevent damage to the ground-fault equipment protection device and to provide strain relief, use clamp ties to secure the device to the wall near the receptacle. Be careful not to damage either the cord or the ground-fault unit.

**Note:** Pipe must be fully insulated.

### 1B For roof and gutter de-icing

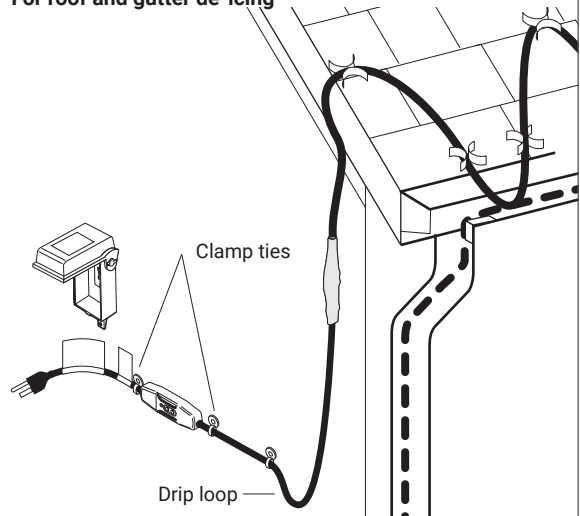

- To prevent damage to the ground-fault equipment protection device and to provide strain relief, use clamp ties to secure the device to the wall near the receptacle. Be careful not to damage either the cord or the ground-fault unit.
- The H908 should be mounted high up, away from passersby to prevent damage to the unit and the risk of shock.
- Include a drip loop as shown to ensure any melt water can drain off roof

### 2A For pipe freeze protection

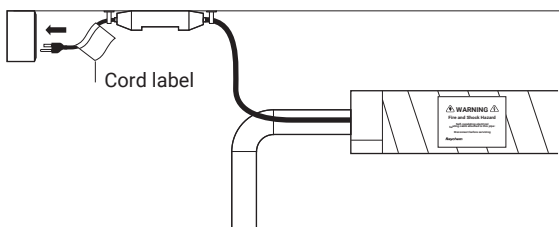

- Plug the heating cable into a 15-A, 120-Vac grounded outlet.
- Make sure that:
  - Cord label is readily visible.
  - Indicator light on the ground-fault equipment protection device is on.
  - Receptacle is properly weatherproofed (if outdoors).
  - Ground-fault equipment protection device and power connection splice will not be submerged.

**Note:** Pipe must be fully insulated

### 2B For roof and gutter de-icing

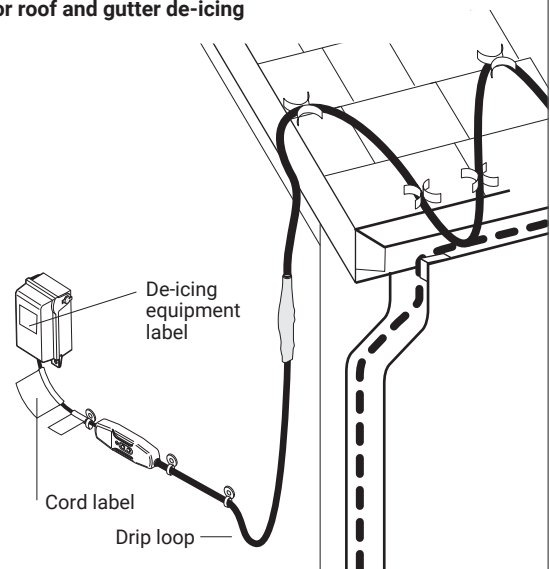

- Plug the heating cable into a 15-A, 120-Vac grounded outlet approved for wet locations.
- Make sure that:
  - Cord label is readily visible.
  - Indicator light on the ground-fault equipment protection device is on.
  - Receptacle is properly weatherproofed.
  - Ground-fault equipment protection device and power connection splice will not be submerged.

## LIMITED WARRANTY

---

CHEMELEX warrants all Raychem wholesale distribution self-regulating heating cables and components against faulty workmanship and use of defective materials for two (2) years from the date of purchase. This warranty can be amended only by a written instrument signed by a duly authorized officer of CHEMELEX. Buyer's exclusive remedy under this warranty shall be to have CHEMELEX, within a reasonable time, repair such goods or supply replacement goods or credit Buyer's account for such goods and accept their return whichever CHEMELEX may elect at its sole discretion. CHEMELEX shall in no event be liable for the cost of removal or installation, for loss or damage to or loss of use of facilities or other property, loss of revenue, loss of use of revenue, loss of anticipated profits, or other damages or costs of any kind whatsoever, whether direct, indirect, incidental, or consequential.

Notwithstanding the foregoing, CHEMELEX shall have no liability whatsoever unless: (a) Buyer promptly notifies CHEMELEX in writing after discovery of an alleged nonconformity and includes a detailed explanation of the alleged nonconformity; (b) Buyer promptly returns the goods to CHEMELEX postage prepaid, at the address obtained by calling Customer Service at 1-800-545-6258 or 650-216-1526; and (c) CHEMELEX' examination of such goods establishes to CHEMELEX' satisfaction that such alleged nonconformities actually exist and occurred in the cause of proper and normal use and were not caused by accident, misuse, neglect, alteration or improper installation, repair or testing or such other cause outside of the responsibility of CHEMELEX under this Limited Warranty.

THE FOREGOING WARRANTY IS IN LIEU OF ALL OTHER REPRESENTATIONS, WARRANTIES, OR CONDITIONS, EXPRESS OR IMPLIED, INCLUDING WITHOUT LIMITATION ANY IMPLIED WARRANTY OF MERCHANTABILITY, FITNESS FOR A PARTICULAR PURPOSE OR NONINFRINGEMENT, AND OF ANY OTHER OBLIGATION OR LIABILITY ON THE PART OF CHEMELEX, WHETHER BY STATUTE, CONTRACT, STRICT LIABILITY, TORT OR OTHERWISE.

If the goods are a consumer product in buyer's jurisdiction, the above exclusion or limitation of incidental or consequential damages and the above disclaimer of implied warranties may not apply. The term of any such implied warranty is limited to the term of this two-year Limited Warranty. Some jurisdictions do not allow limitations on how long an implied warranty lasts, so the above limitation may not apply. This warranty gives consumers specific legal rights, and consumers may also have other rights, which vary by jurisdiction.

**North America**

Tel +1 800 545 6258  
info@chemelex.com

**Latin America**

Tel +1 713 868 4800  
info@chemelex.com

**Europe, Middle East, Africa, India**

Tel +32 16 213 511  
Fax +32 16 213 604  
info@chemelex.com

**Asia Pacific**

Tel +86 21 2412 1688  
infoAPAC@chemelex.com

---

**chemelex**  
*excellence is everything*

**Raychem**

**Tracer**

**Pyrotenax**

**Nuheat**