

Raychem

NGC-40 Control System

Installation Manual

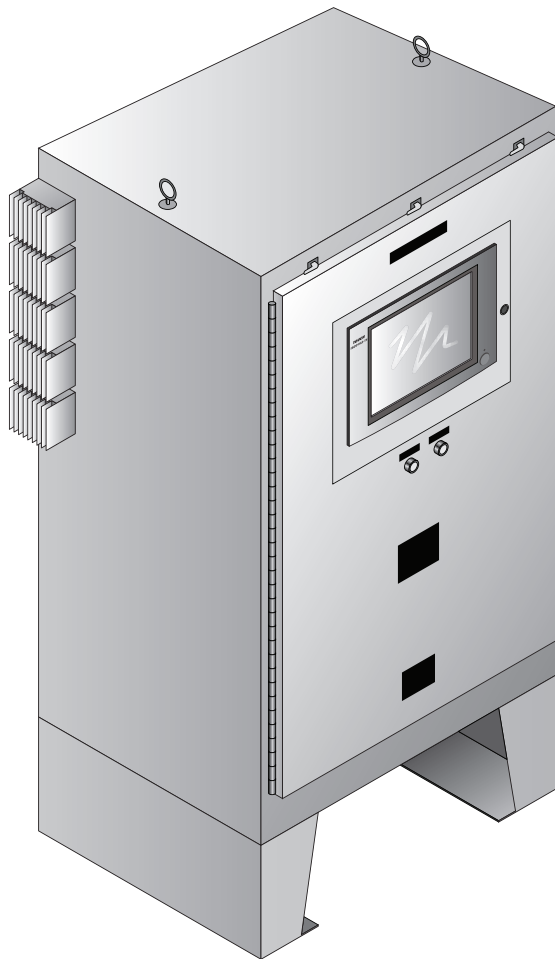

CONTENTS

Section 1. Overview	3
1.1 Introduction.....	3
Section 2. Installation and Wiring.....	4
2.1 Introduction	4
2.2 Initial Inspection.....	4
2.3 Operating Environment.....	4
2.4 Installation Location	4
2.5 Mounting Procedures	5
2.6 Wiring Procedures.....	5
2.6.1 INCOMING POWER WITH DISTRIBUTION SYSTEM	5
2.6.2 OUTGOING POWER WITH DISTRIBUTION SYSTEM.....	6
2.6.3 INCOMING/OUTGOING POWER WITHOUT DISTRIBUTION PANEL BOARD	7
2.6.4 INCOMING RTD WIRING.....	8
2.6.5 NGC-40-BRIDGE SWITCH SETTINGS	9
2.6.6 OPTIONAL RMM2 CONNECTION	10
2.6.7 OPTIONAL TOUCH 1500R CONNECTIONS.....	11
2.6.8 OPTIONAL DIGITAL INPUTS.....	13
2.6.9 OPTIONAL ALARM RELAY	14
2.6.10 CONNECTING TO REM PC W/ Raychem SUPERVISOR OR CUSTOMER DCS SYSTEM	15
2.6.11 CONNECTING MULTIPLE NGC-40 PANELS (BRIDGES) USING RS-485 (COM 1).....	18
Section 3. Raychem NGC-40 Components and Operation	20
3.1 NGC-40-HTC and HTC3	20
3.2 NGC-40-BRIDGE	25
3.3 NGC-40-IO	29
3.4 NGC-40-PTM.....	32
3.5 Touch 1500 and Touch 1500R Touch Screens	35
3.6 Touch 1500-HAZ.....	40
Section 4. Appendix A	43
4.1 Software License Agreement	43
4.1.1 SOFTWARE LICENSES	43

SECTION 1. OVERVIEW

1.1 Introduction

The Raychem NGC-40 is a fully functional, self-contained control and monitoring system used with electric heat-tracing systems. It is designed for installation requiring minimal wiring on site. This manual provides information pertaining to the installation, operation, testing, adjustment, and maintenance of all components of the Raychem NGC-40 Control System. For information about how to program the Raychem NGC-40 Control System, see the Raychem NGC-40 Control System with DTS User Guide (H58269).



A typical Raychem NGC-40 Control System consists of at least a one Power and Termination module (NGC 40 PTM), one Bridge module (NGC-40-BRIDGE), one or more Heat-Trace Controllers (NGC-40-HTC or HTC3) and one IO module (NGC-40-IO). Additional IO modules (NGC-40-IO) are optional and may be used. The system is intended to provide configuration and component flexibility so that it may be optimized for a customer's specific needs.

The information in this document coincides with the specific releases of firmware (listed in the table below) for the Heat-Trace Controllers (NGC-40-HTC or HTC3) and Bridge module (NGC-40-BRIDGE) components. As Chemelex releases new firmware to significantly modify or enhance any of these components, new documentation will accompany these releases. To ensure that the correct documentation is being used for your particular version of the NGC-40-HTC/HTC3 and NGC-40-BRIDGE, compare the firmware version number of each component against the number listed in the table below. As subsequent changes are made, supplements to this document will be included in manuals shipped after the firmware is released. Supplements will make specific reference to the operation or functional change.

Copies of this manual and updates may be downloaded from the Literature section of chemelex.com.

Component	Version number
NGC-40-HTC	4.x
NGC-40-HTC3	4.x
NGC-40-IO	3.x
NGC-40-BRIDGE	5.x

Important Warnings and Notes

The following icons are used extensively throughout this manual to alert you to important warnings  that affect safety and to important notes  that affect the proper operation of the unit. Be sure to read and follow them carefully.

SECTION 2. INSTALLATION AND WIRING

2.1 Introduction

WARNING:

Electrical Hazard! Ensure all personnel involved in installation, servicing, and programming are qualified and familiar with electrical equipment, its ratings, safe electrical practices and national and local electrical codes. Multiple voltages and signal levels may be present during the installation, operation, and servicing of this product. Do not power the NGC-40 until the safety provisions specified in this manual have been observed.

This section includes information regarding the initial inspection, preparation for use, and wiring instructions for the components of the Raychem NGC-40 Control System.

2.2 Initial Inspection

Inspect the shipping container for damage. If the shipping container or cushioning material is damaged, it should be kept until the contents of the shipment have been verified for completeness and the equipment has been checked mechanically and electrically. Procedures for installing the Raychem NGC-40 Control System are given in this section. If the shipment is incomplete, mechanically damaged, defective in any way, or does not pass the electrical performance tests, notify the nearest Chemelex representative. If the shipping container is damaged, or the cushioning material shows signs of stress, notify the carrier as well as your Chemelex representative. Keep the shipping materials for the carrier's inspection.

2.3 Operating Environment

There are three types of enclosures available with the Raychem NGC-40 panel, as shown below.

Enclosure Type	Area Classification	Usage
TYPE-12	Nonhazardous (Unclassified) Locations	Indoors
TYPE-4/3R	Nonhazardous (Unclassified) Locations	Outdoors, painted steel
TYPE-4/3R with Z purge option	Hazardous Locations <ul style="list-style-type: none">• Class I, Division 2, Groups A, B, C, D• Class I, Zone 2, Group IIC	Outdoors, painted steel with mechanical relays
TYPE-4X	Hazardous Locations <ul style="list-style-type: none">• Class I, Division 2, Groups A, B, C, D• Class I, Zone 2, Group IIC	Outdoors, stainless steel with solid-state relays

WARNING:

Shock Hazard. Some wiring configurations will use more than one power source. All power sources must be de-energized prior to performing any maintenance on a module or its heating circuit. The operating environment should be within the limitations specified for the Raychem NGC-40 components as outlined in Appendix A.

2.4 Installation Location

The wide ambient operating temperature range of the Raychem NGC-40 Control System permits installation in almost any convenient location. Considerations should include: expected atmospheric conditions (weather), accessibility for maintenance and testing, the location of existing conduits, and hazardous location rating. Ambient temperature conditions may affect load current ratings.

WARNING:

Fire Hazard. Always be sure that the intended location is classified as an area that the product is approved for use in as defined by Article 500 of the National Electrical Code and/or Part I, Section 18 of the Canadian Electrical Code.

2.5 Mounting Procedures

Each Raychem NGC-40 panel includes a set of "As Built" drawings that have been engineered, designed, and drafted based upon the model number and any special requirements that were requested when ordering. The "As Built" drawings include an elevation/layout (with bill of materials) and schematics. If these drawings are not included, contact your Chemelex Representative and request the "As Built" drawings for your panel. Upon request, an electronic copy of these drawings can be provided.

For mounting the panel, locate the elevation and layout drawing which includes a bill of materials. The enclosure mounting information will be provided on the "As Built" drawings.

2.6 Wiring Procedures

Refer to the "As Built" drawings for wiring of incoming/outgoing power and incoming RTD connections. The Raychem NGC-40 panel can be purchased with, or without, a distribution panel board.

2.6.1 INCOMING POWER WITH DISTRIBUTION SYSTEM

Main Circuit Breaker

Locate the main circuit breaker in the panel by using the supplied elevation/layout drawing, and connect per the associated schematic drawings. Depending upon the size and type of main circuit breaker and voltage loss calculations, use the appropriate size and number of wires to connect directly to the main circuit breaker, and panel board neutral and ground bus in the panel.

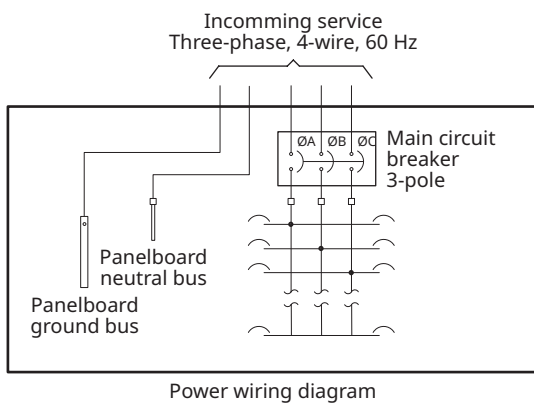

Fig. 2.1 Main circuit breaker wiring

Branch Circuit Breakers

The branch circuit breakers are pre-wired to the contactors or solid-state relays in the panel, so no further incoming power wiring is required.

2.6.2 OUTGOING POWER WITH DISTRIBUTION SYSTEM

Load Power Terminal Blocks

Locate the outgoing heater terminal blocks using the supplied elevation/layout drawing, and connect per the associated schematic drawings. Depending upon the size of the branch circuit breaker and voltage loss calculations, use the appropriate size and number of wires to connect from the panel's Load Power Terminal Blocks to the heat-trace power junction box.

Single pole C.B.

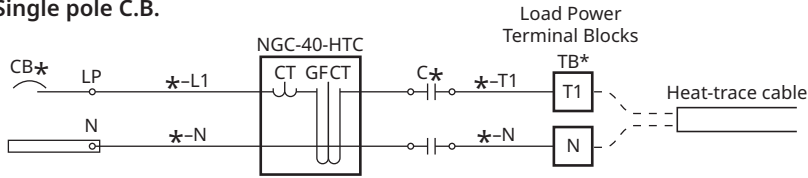

Two pole C.B.

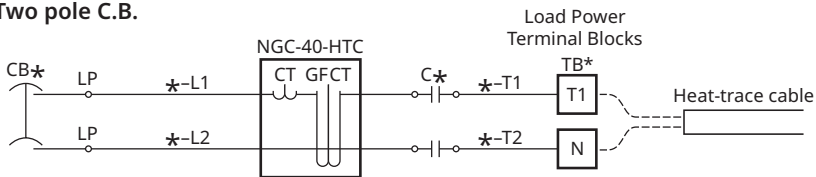

Three pole C.B. (Three-phase, 3-wire)

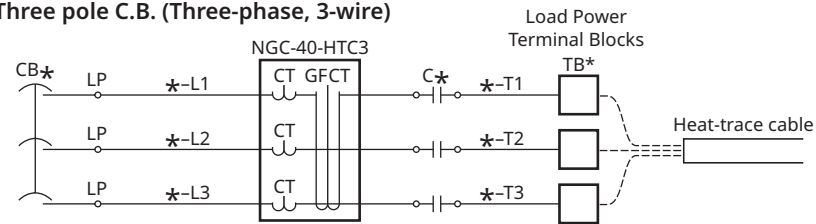

Three pole C.B. (Three-phase, 4-wire)

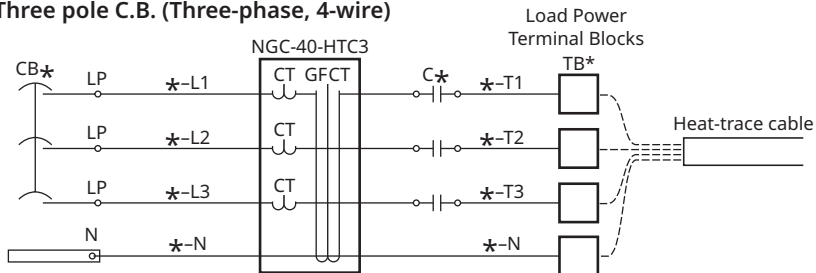

Fig. 2.2 Heat-trace power wiring diagram

2.6.3 INCOMING/OUTGOING POWER WITHOUT DISTRIBUTION PANEL BOARD

Line Power Terminal Blocks

Locate the incoming power terminal blocks in the panel using the supplied elevation/layout drawings and connect per the associated schematic drawing. Depending upon size and type of the remotely located branch circuit breakers, use the appropriate size and number of wires to connect directly to the Line Power Terminal Blocks.

Load Power Terminal Blocks

Locate the outgoing power terminal blocks in the panel using the supplied elevation/layout drawings and connect per the associated schematic drawing. Depending upon size and type of the remotely located branch circuit breakers, use the appropriate size and number of wires to connect from the Load Power Terminal Blocks to the heater's power connection box.

Single pole C.B.

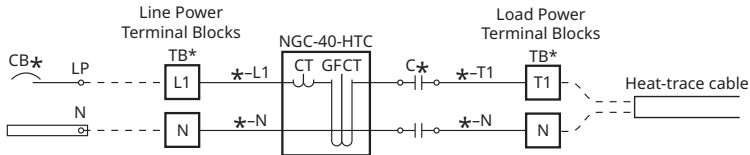

Two pole C.B.

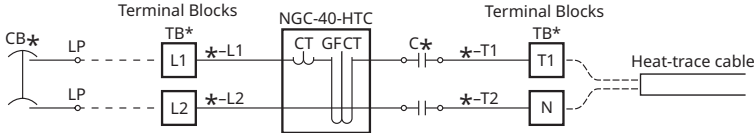

Three pole C.B. (Three-phase, 3-wire)

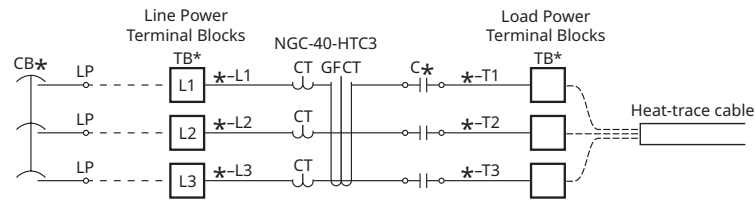

Three pole C.B. (Three-phase, 4-wire)

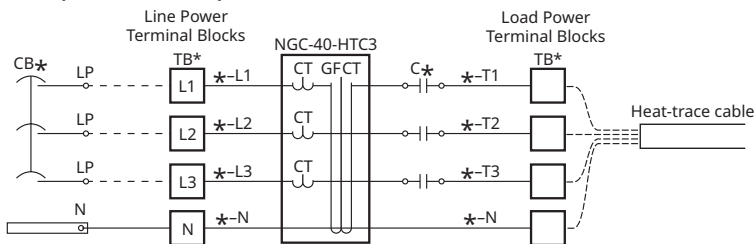

Fig. 2.3 Load power terminal block configurations

2.6.4 INCOMING RTD WIRING

Nonhazardous and Hazardous Location Installations Wired to Terminal Block in Panel Each Raychem NGC-40-HTC/HTC3 module has one RTD input. The RTD wiring from the NGC 40-HTC/HTC3 have been pre-wired to RTD terminals. The field RTD wiring (3-wire with shield) will be terminated by the installer at the RTD terminal blocks. Refer to the “As Built” Drawings for the RTD Termination Schedule. Refer to Section 3.1 for additional NGC-40-HTC/HTC3 wiring information.

RTD Connections - North American Installation Technique

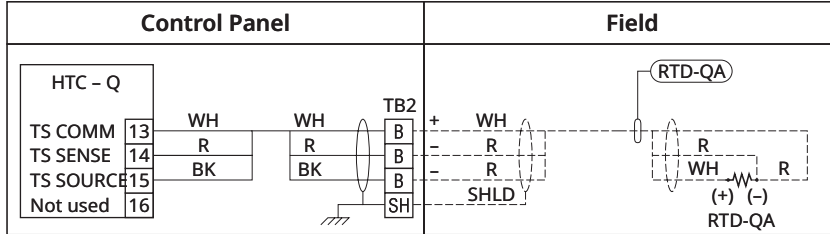

Fig. 2.4 Typical RTD installation from the NGC-40-HTC/HTC3 module in a North American style panel

RTD Connections - European Installation Technique

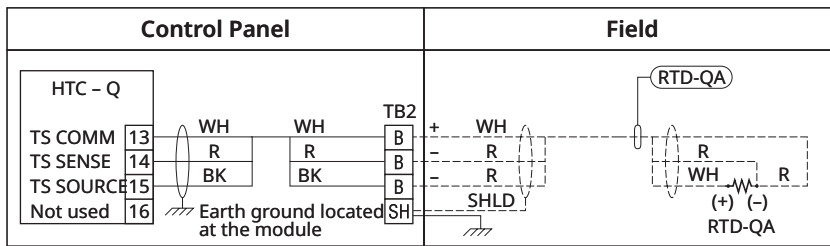

Fig. 2.5 Typical RTD installation from the NGC-40-HTC/HTC3 module in an European style panel

Optional RTD inputs via the NGC-40-IO module

One NGC 40 IO module is mandatory. The digital output of this module is used for activating the Common Alarm Light on the Raychem NGC 40 panel door. Additional NGC 40 IO modules are optional components that may or may not be included in a panel depending on its design. If used, each Raychem NGC-40-IO module provides up to four additional RTD inputs. The RTD wiring from the NGC-40-IO have been pre-wired to RTD terminals. The field RTD wiring (3-wire with shield) will be terminated by the installer at the RTD terminal blocks. Refer to the “As Built” Drawings for the RTD Termination Schedule. Refer to Section 3.3 for additional NGC-40-IO wiring information.

RTD Connections - North American Installation Technique

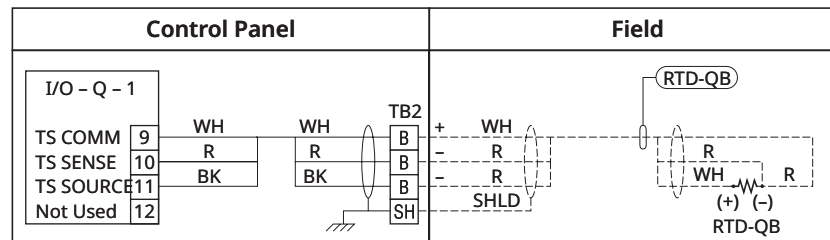

Fig. 2.6 Typical RTD installation from the NGC-40-IO module in a North American style panel

RTD Connections - European Installation Technique

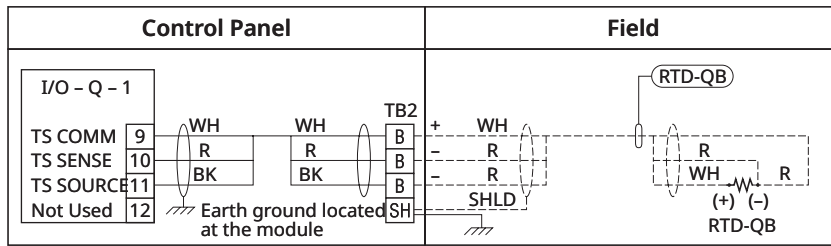

Fig. 2.7 Typical RTD installation from the NGC-40-IO module in a North American style panel

2.6.5 NGC-40-BRIDGE SWITCH SETTINGS

User Interface - Configuration Switch

A slide switch is provided on the front of the module to allow the user to set the RS-232 (COM 3) into a known state, as shown in the following table:

Bridge Module Settings	Switch Position	
	SET Configuration mode	RUN Normal operating mode
Modbus address	1	
Local RS-232		
Protocol	RTU	
Data rate	9600 baud	Settings based on the user configuration parameters
Data bits	8	
Stop bits	2	
Parity	No parity	

If the present user parameters of the communications port of an NGC-40-BRIDGE are not known, the NGC-40-BRIDGE can be placed in the SET mode by its Configuration Switch and the Raychem Supervisor or any other device that needs to communicate with the NGC-40-BRIDGE, can then be used to establish communications. The user parameters (including those of the communications port) can then be read.

While in the SET mode, modifications to the NGC-40-BRIDGE user parameters of the communications port will be saved but will not take effect until the Configurations Switch is moved to the RUN mode.

The parameters of the two RS-485 ports (COM 1 and COM 2) and the ethernet port are not affected by the position of the Configuration Switch.

For firmware upgrades only: When in SET mode, the NGC-40-BRIDGE 10/100 LAN (Ethernet) port settings are those defined by the Boot loader.

In the RUN mode, these port settings are defined by the user parameters of the Bridge (the default user parameters are the same as those in the table above).

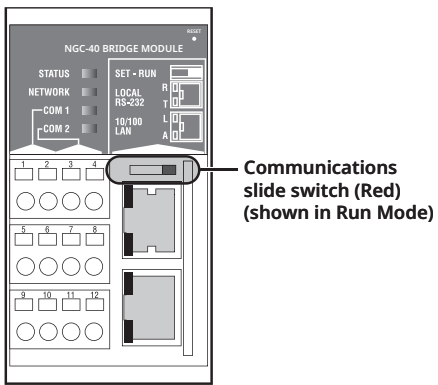

Fig. 2.8 Communication Slide Switch

2.6.6 OPTIONAL RMM2 CONNECTION

When using the field mounted RMM2 for RTD input, it must be connected to the COM2 In as shown below.

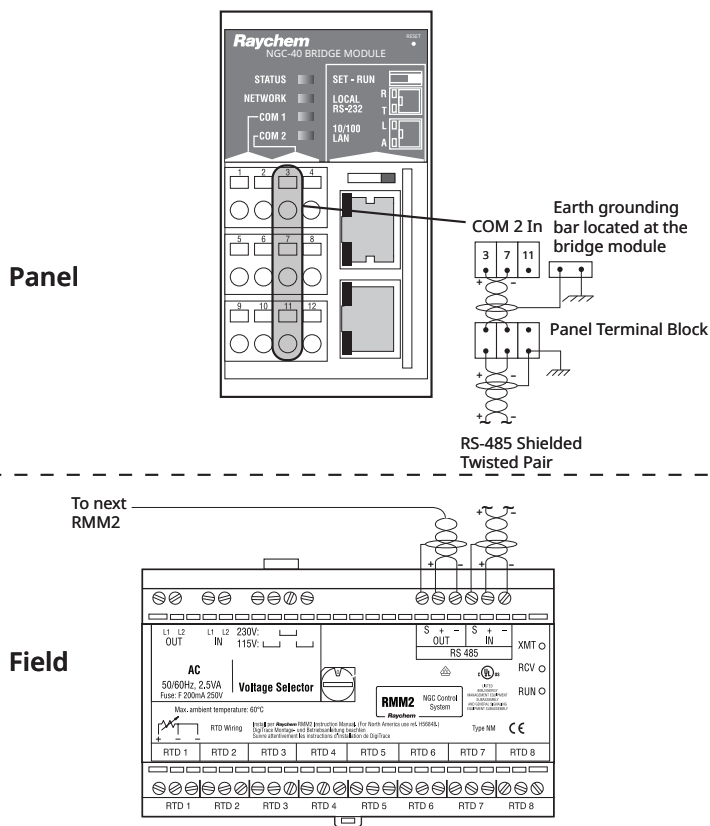

Fig. 2.9 RMM2 Connection

2.6.7 OPTIONAL TOUCH 1500R CONNECTIONS

When using the Touch 1500R (Remote User Interface Terminal) with the NGC-40 system, the user must connect main power to the Touch 1500R and communication cable from the NGC-40-BRIDGE to the Touch 1500R.



Fig. 2.10 Touch 1500R

Connecting Main Power to the Touch 1500R

Use only copper conductors for field wiring. A close-up of the power connection terminals is shown below. This connection energizes the Raychem TOUCH 1500 electronics only; it does not provide power to the heat tracing or contactor coils.

IMPORTANT: If the Raychem TOUCH 1500R controller has a different source of power than the heat tracing, it may be worthwhile to install an uninterruptible power supply (UPS) so the unit can continue to control and/or monitor the heat tracing in the event of a localized power failure.

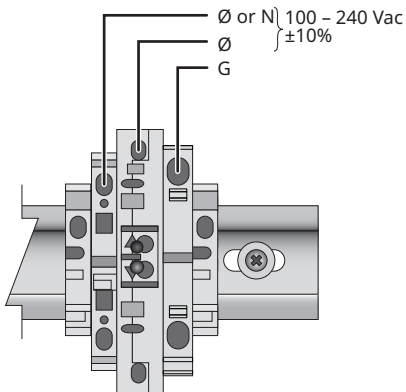

Fig. 2.11 Touch 1500R Main Power Terminal Block

Connecting RS-485 Field Port Communication

The NGC-40-BRIDGE communicates with the TOUCH 1500R over an RS-485 network, which can have a total cable length of no more than 1200 m (4000 ft), as required.

The RS-485 communicating cable shall be a shielded, two conductor (twisted pair) cable.

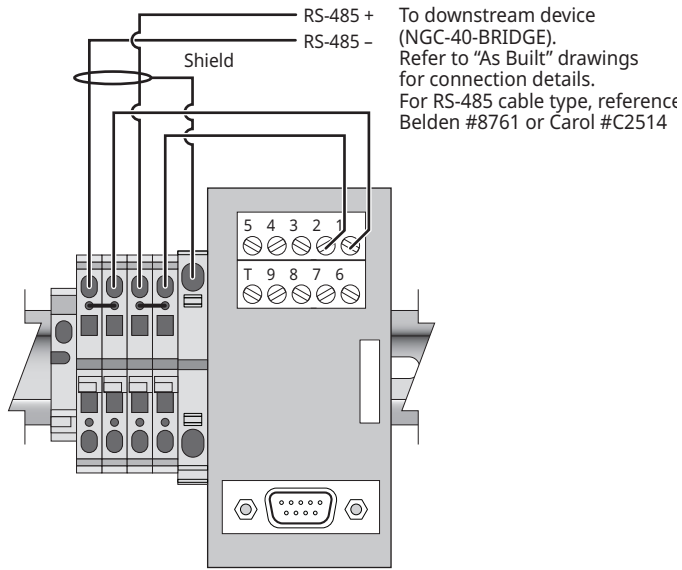

Fig. 2.12 Touch 1500R RS-485 Terminal Block

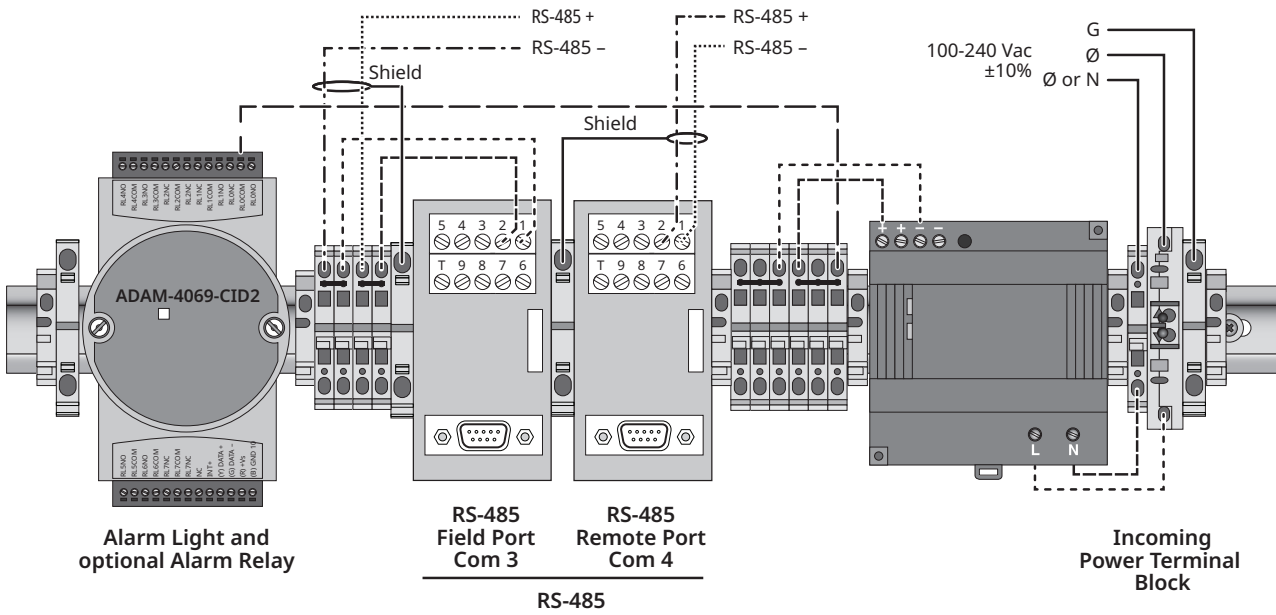

Fig. 2.13 Touch 1500R Wiring Diagram

2.6.8 OPTIONAL DIGITAL INPUTS

Both the Raychem NGC-40-HTC/HTC3 and the Raychem NGC-40-IO modules have a digital input which is programmable and may be used for various functions such as forcing outputs on and off. The field wiring for these connections will be wired directly to the module as shown below.

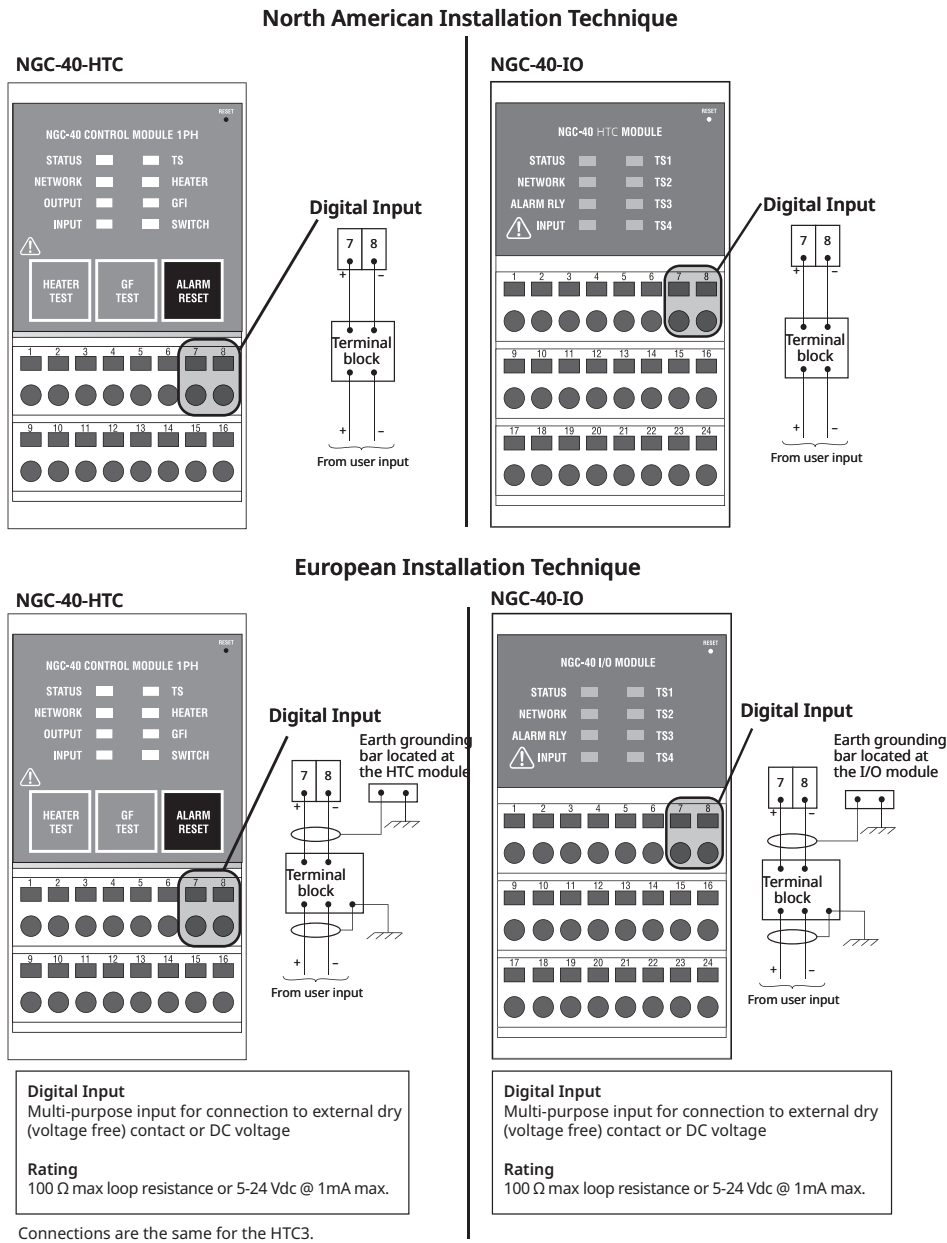

Fig. 2.14 Digital Inputs

2.6.9 OPTIONAL ALARM RELAY

Both the Raychem NGC-40-HTC/HTC3 and the Raychem NGC-40-IO modules have an alarm relay which can be used to control an external annunciator. The field wiring for these connections will be wired directly to the module as shown below.

WARNING: Shock Hazard. Disconnect from live voltage prior to accessing terminals.

- Multi-purpose. Alarm relay energized in normal state.
- The alarm relay is configured as Fail Safe
- The alarm relay connections provide a form C dry contact:
 - 250 V / 3A 50/60 Hz (CE)
 - 277 V / 3A 50/60 Hz (cCSAus)
- The NO (normally open) contact is open in non-energized condition. When energized, it closes during normal conditions and will open upon an alarm condition or power failure.
- The NC (normally closed) contact is closed in non-energized condition. When energized, it opens during normal conditions and will close upon an alarm condition or power failure.
- Relay contact rated

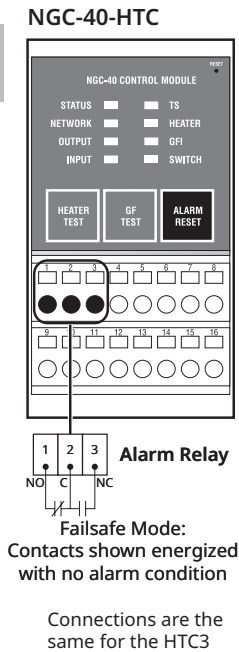

Fig. 2.15 NGC-40-HTC/HTC3 Alarm Relay

WARNING: Shock Hazard. Disconnect from live voltage prior to accessing terminals

- The common alarm provides a form C contact:
 - 250 V / 3A 50/60 Hz (CE)
 - 277 V / 3A 50/60 Hz (c-CSA-us)
- The alarm relay is configured as Fail Safe.
- The NO (normally open) contact is open in non-energized condition. When energized, it closes during normal conditions and will open upon an alarm condition or power failure.
- The NC (normally closed) contact is closed in non-energized condition. When energized, it opens during normal conditions and will close upon an alarm condition or power failure.
- Relay contact rated

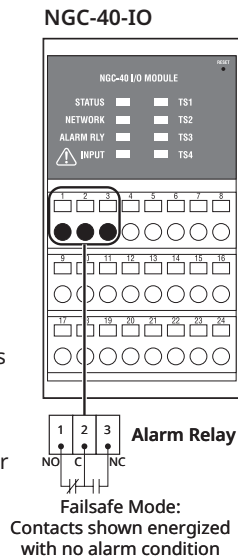

Fig. 2.16 NGC-40-IO Alarm Relay

2.6.10 CONNECTING TO REM PC W/ Raychem SUPERVISOR OR CUSTOMER DCS SYSTEM

The Raychem NGC-40-BRIDGE must communicate with a host computer using Raychem Supervisor in order to load set point information and monitor the HTCs through the NGC 40 BRIDGE's external communication ports. The NGC-40-BRIDGE provides ports for RS 232, RS 485, and Ethernet communications. The RS-485, RS-232 and Ethernet ports could also communicate with a distributed control system (DCS).

RS-232 Serial Connection

The RS-232- port can be used as a direct connection to a single PC located within 50 ft of the panel. For an RS-232 connection, a 3 ft long RJ-11 to 9 pin female D-connector (NGC part number 10332-005) has been provided with the NGC-40 panel. Plug the RJ-11 connector into the RS-232 connector on the NGC-40-BRIDGE and the other end into the 9-pin connector on the user's computer.

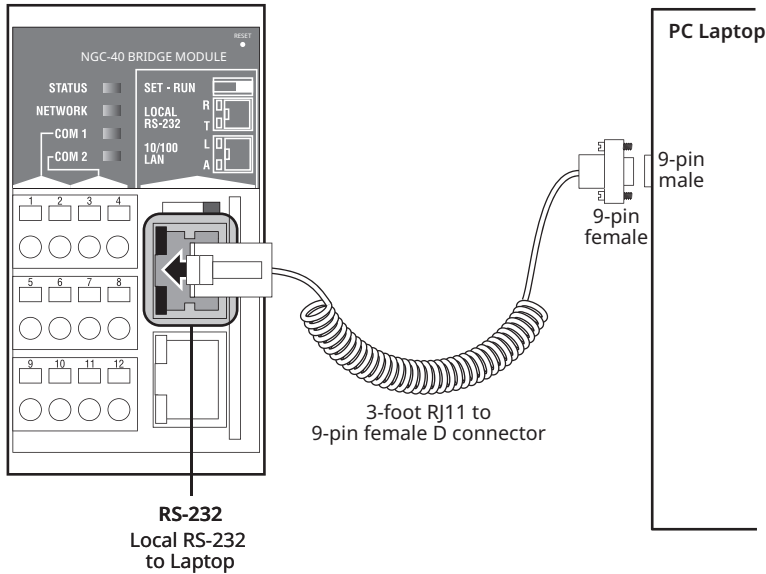

Fig. 2.17 RS-232 Serial Connection

RS-485 Serial Connection

Use the RS-485 port when multiple NGC-40-BRIDGE modules are to be connected to a host computer. If the connection is longer than 1,220 m (4,000 ft), a repeater is required. An RS-485 to RS-232 or an RS-485 to USB converter may be required to make the connection to the user's PC.

Connection Diagram - North American Installation Technique

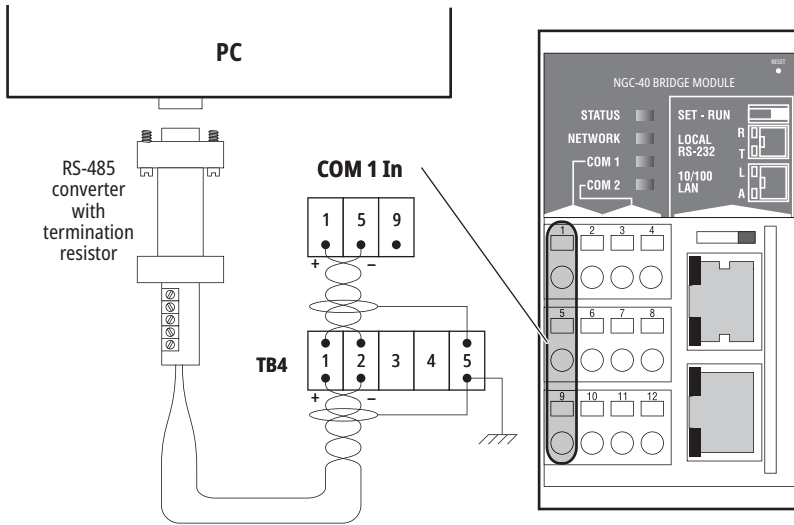

Fig. 2.18 North American RS-485 Serial Connection - COM1

Connection Diagram - European Installation Technique

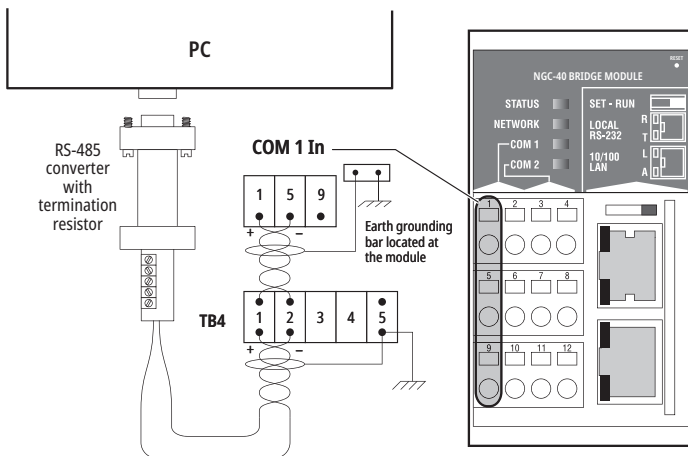

Fig. 2.19 European RS-485 Serial Connection - COM1

Ethernet Connection

The Ethernet port can be used to connect multiple NGC-40-BRIDGE modules to a host computer by connecting to the user's LAN system.

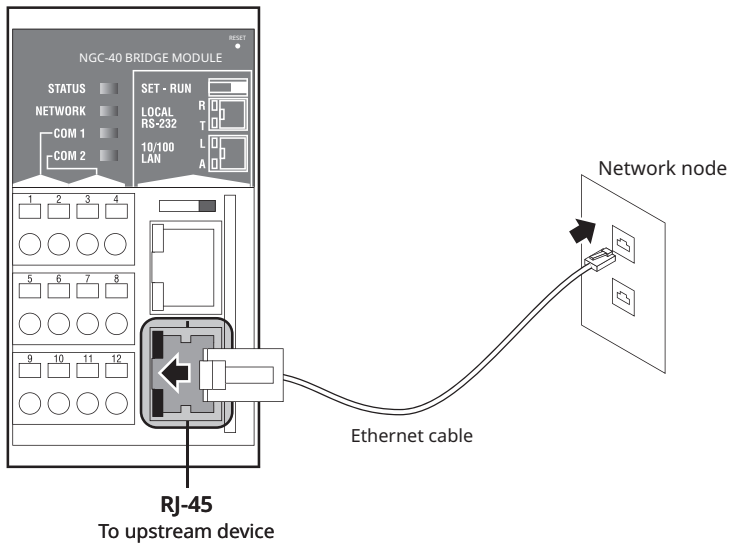

Fig. 2.20 Ethernet Connection

2.6.11 CONNECTING MULTIPLE NGC-40 PANELS (BRIDGES) USING RS-485 (COM 1)

A termination resistor is required at the beginning and the end of the RS-485 communication network. In each panel a termination resistor has been provided on COM 1 (Out). If multiple panels are connected together on an RS-485 network, the COM 1 (Out) termination resistor needs to be removed from all panels except for the last panel.

CONNECTION DIAGRAM - NORTH AMERICAN INSTALLATION TECH-NIQUE

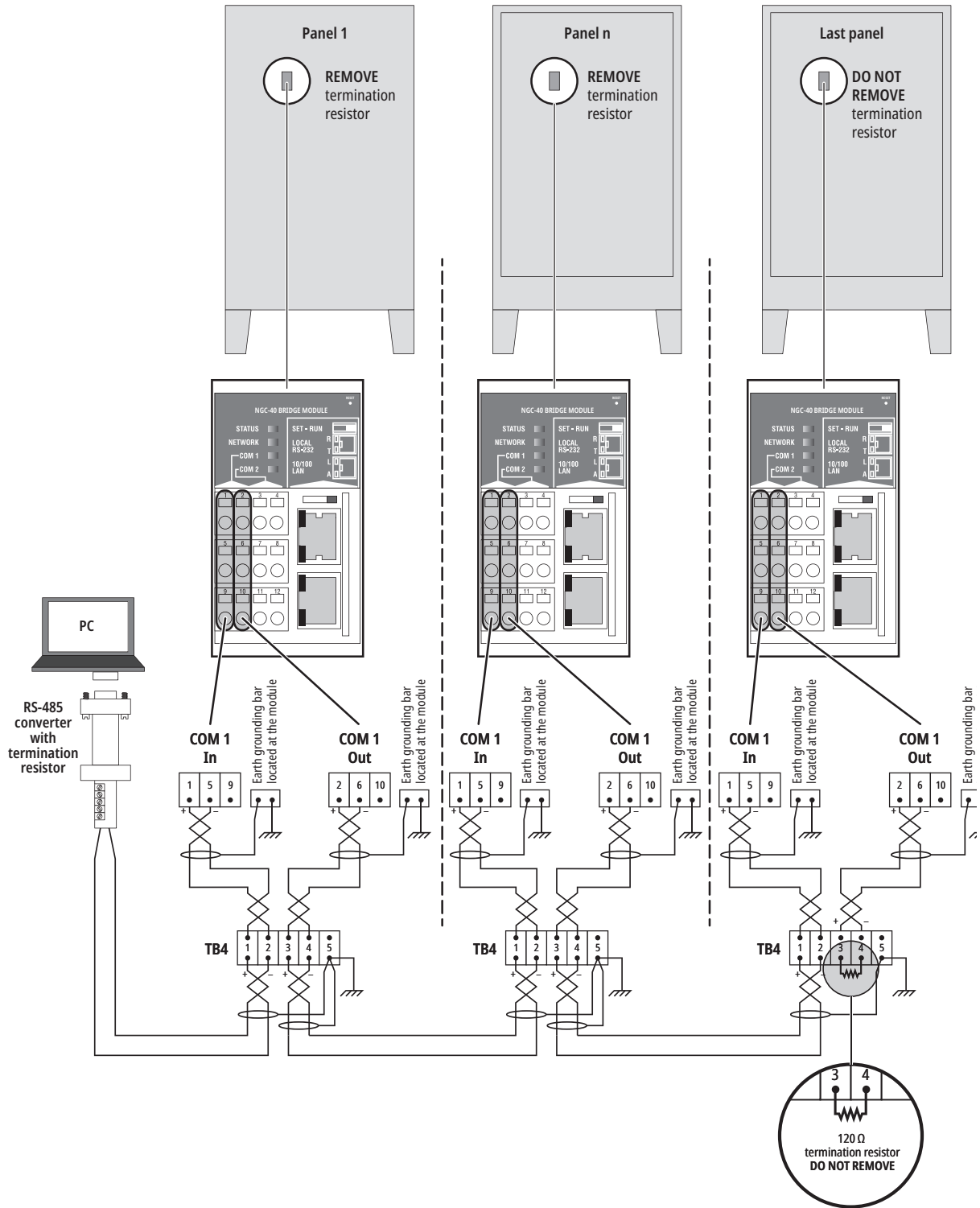

Fig. 2.21 North American termination resistor layout

CONNECTION DIA-GRAM - EUROPEAN INSTALLATION TECHNIQUE

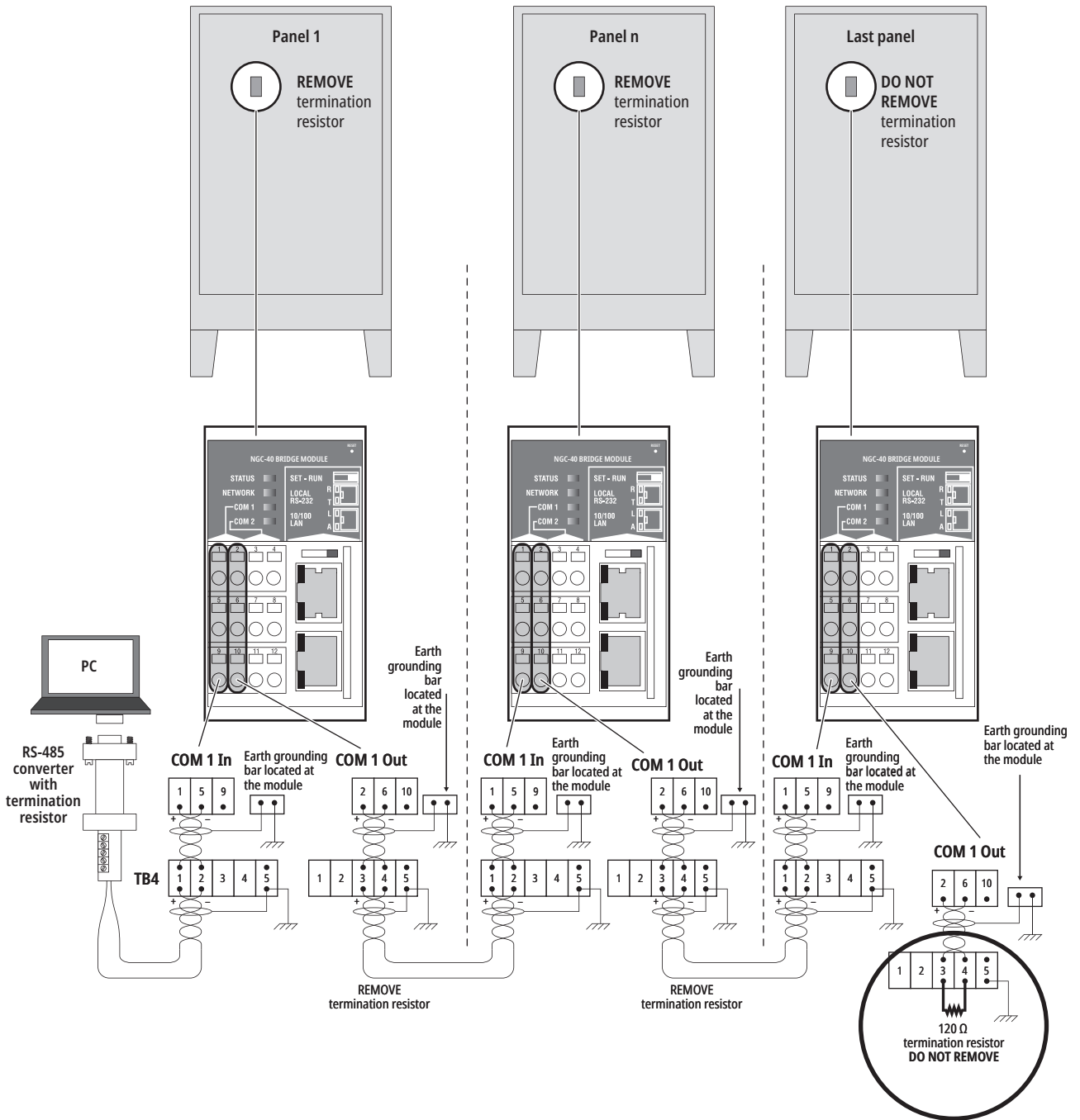
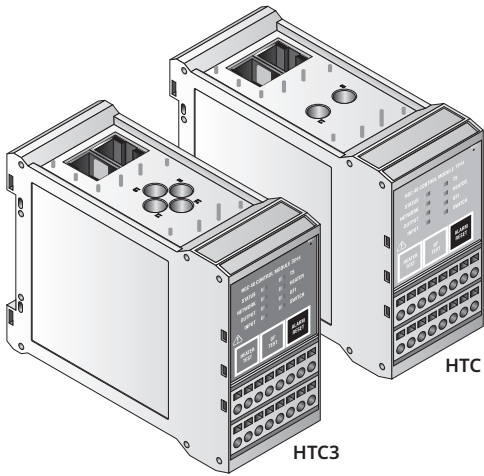

Fig. 2.22 European termination resistor layout

SECTION 3. RAYCHEM NGC-40 COMPONENTS AND OPERATION

The Raychem NGC-40 heat-trace system is comprised of a number of modular components, allowing the ultimate in design flexibility. This section describes the NGC-40 control and monitoring components (excluding the optional distribution section).

3.1 NGC-40-HTC and HTC3



The NGC-40-HTC (for single-phase heaters) and NGC-40-HTC3 (for three-phase heaters) modules are used to control either a solid-state relay or contactor within the NGC-40 control and monitoring system. This module also has one alarm output and one digital input. The alarm output can be used to control an external annunciator. The digital input is programmable and may be used for various functions such as forcing outputs on and off. Other features of this module include ground-fault and line current sensing for both HTC and HTC3. The front panel of the HTC module has LED indicators for various status conditions. The front panel also provides a ground-fault and heater test button.

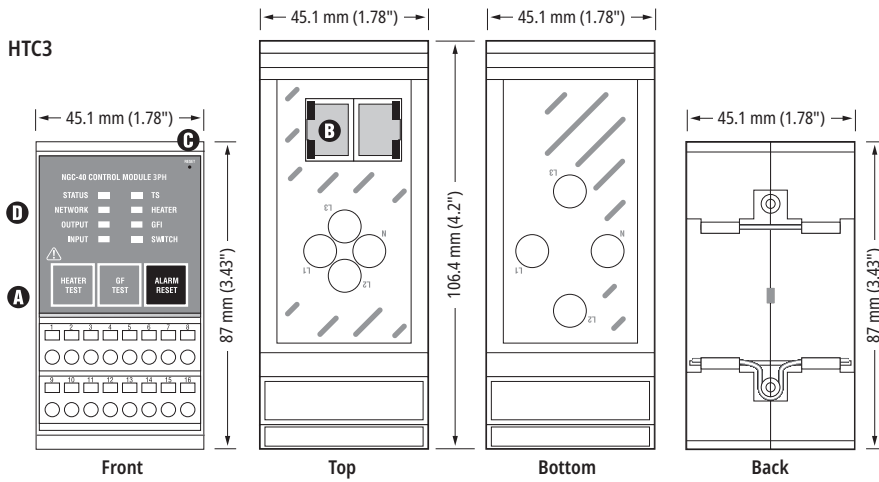
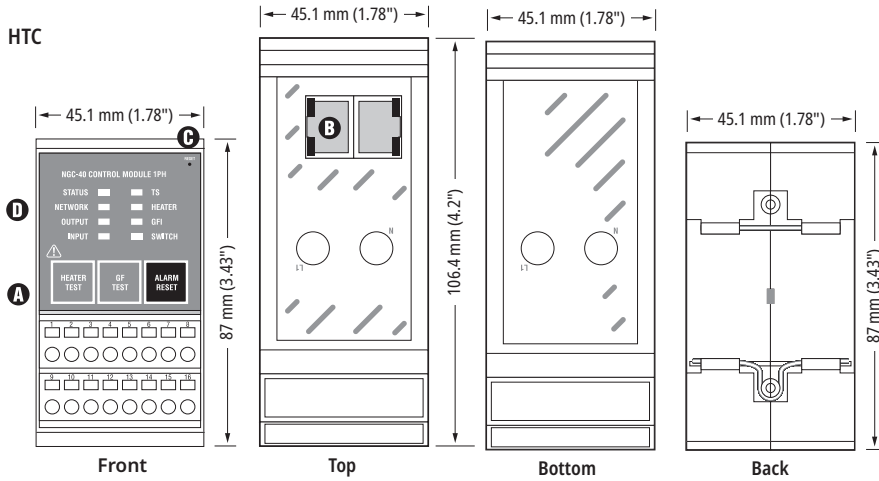

A. Wiring Terminals

1 Δ	Alarm relay N.O.	7	Digital In +	13	TS COM (Wht)
2 Δ	Alarm relay COM	8	Digital In -	14	TS Sense (Red)
3 Δ	Alarm relay N.C.	9 Δ	Line In	15	Not used
4	Not used	10 Δ	Line Out	16	Not used
5	SSR Out +	11 Δ	Coil Out	⚠ WARNING: Shock Hazard. Disconnect from live voltage prior to accessing terminals	
6	SSR Out -	12	Not Used		

B. CAN/BUS MODULE POWER

C. RESET

D. STATUS LEDs

STATUS: Indicates status of HTC/HTC3 module	INPUT: Shows status of digital input	TS: Indicates the temperature alarm status
Off No power	Off Input is inactive (open)	Off No alarm
Green Normal operation, no internal faults	Green Input is active (shorted)	Red High or low temperature alarm
Yellow In Factory mode	Flash R Ext. input source failure	Flash R Temperature sensor failure
Red HTC/HTC3 operating status		
Flash R Internal Fault:	OUTPUT: Shows status of contactor or SSR	GFI: Indicates ground-fault status
Flash R/G Factory status	Off Output off	Off No alarm
Flash R/Y Internal fault detected	Green Follows output state	Red High or low ground-fault alarm
		Flash R Ground-fault trip alarm
NETWORK: Indicates CAN network activity	HEATER: Indicates the heater's alarm status	SWITCH: Indicates contactor/SSR switch status
Off No network activity	Off No alarm	Off No alarm
Green Flicker on receipt of network data	Red High or low current or resistance alarm	Red Contactor cycle count alarm
Yellow Flicker on transmission of network data	Flash R Overcurrent trip alarm	Flash R Switch failed shorted on
Flash R Network communication failure		

General

Approvals and Certifications



Hazardous Locations

Class I, Div. 2, Groups A,B,C,D T4
Class I, Zone 2, AEx nC IIC T4 IP20
Ex nL nC IIC T4 X
-40°C ≤ Ta ≤ +65°C

Conforms to:

FM Class Number 3600 (11/98)
FM Class Number 3611 (10/99)
ANSI/UL STD. 60079-15-2009
UL STD. 61010-1

Certified to:

CAN/CSA STD. C22.2 No. 213-M1987 (R2004)
CAN/CSA STD. C22.2 No. 61010-1:2004
EN 61010-1 (2001)
CAN/CSA STD. E60079-15:02 (R2006)



(Russia, Kazakhstan, Belarus)

For other countries contact your local Chemelex representative.

Supply voltage	24 Vdc, ± 10%
Internal power consumption	< 2.4 W per NGC-40-HTC/HTC3 module
Ambient operating temperature	-40°C to 65°C (-40°F to 149°F)
Ambient storage temperature	-40°C to 75°C (-40°F to 167°F)
Environment	PD2, CAT III
Max. altitude	2,000 m (6,562 ft)
Humidity	5 – 90% noncondensing
Mounting	Din Rail – 35 mm

Electromagnetic Compatibility

Emissions	EN 61000-6-3 Emission standard for residential, commercial and light industrial environments
Immunity	EN 61000-6-2 Immunity standard for industrial environments

Temperature Sensors

Type	100 W, platinum RTD, 3-wire, a = 0.00385 ohms/ohm/°C Can be extended with a 3-conductor shielded cable of 20 W maximum per conductor
	100 W, Ni-Fe, 2-wire Can be extended with a 2-wire shielded cable of 20 W maximum per conductor
Quantity	One per NGC-40-HTC/HTC3 module

Current Sensors (internal to the module)

Quantity per NGC-40-HTC/HTC3	1 for ground-fault measurements
Quantity per NGC-40-HTC	1 for single-phase line current measurements
Quantity per NGC-40-HTC3	3 for three-phase line current measurements
Maximum Line to Line Voltage	1000 Vac

Alarm Relay

Dry contact relay (voltage free)	Relay contact rated 250 V / 3 A 50/60 Hz (CE) and 277 V / 3 A 50/60 Hz (cCSAus). Alarm relay is programmable. NO and NC contacts available.
Contactor Output Relay	Relay contact rated 250 V / 3 A 50/60 Hz (CE) and 277 V / 3 A 50/60 Hz (cCSAus).

Digital Input

Multi-purpose input	Multi-purpose input for connection to external dry (voltage-free) contact or DC voltage. May be user programmable for: not used / force off / force on functions. It can be configured to be active open or active closed.
---------------------	---

CAN Networking Port

Type	2-wire isolated CAN-based peer to peer network. Isolated to 24 Vdc – verified by 500 Vrms dielectric withstand test
Quantity	One input standard per control point
Connection	Two 8-pin RJ-45 connectors (both may be used for Input or Output connections)
Protocol	Proprietary NGC-40
Cable length	10 m (33 ft) maximum

Quantity	Up to 80 HTC/HTC3 and IO modules per network segment
Address	Unique, factory assigned
Connection terminals	
Wiring terminals	Cage clamp, 0.5 to 2.5 mm ² (24 to 12 AWG)
Housing	
Size	45.1 mm (1.78 in) wide x 87 mm (3.43 in) high x 106.4 mm (4.2 in) deep
Line Current Sensors	
Max current	60 A
Accuracy	± 2% of reading
Ground-Fault Sensor	
Range	Range 10 – 250 mA
Accuracy	± 2% of range
Outputs	
SSR output	12 Vdc @ 45 mA max per output

3.2 NGC-40-BRIDGE

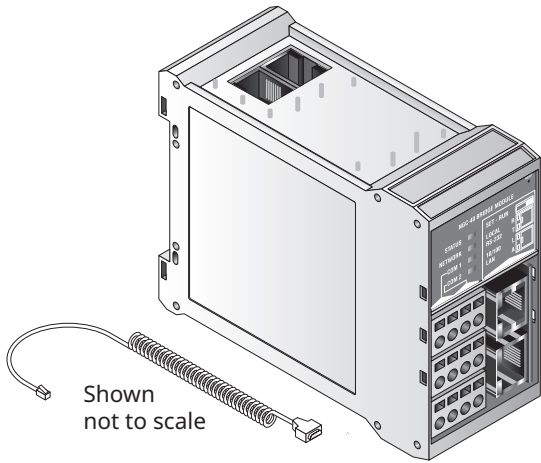

The NGC-40-BRIDGE module provides the interface between a panel's internal CAN-based network and upstream devices. Multiple communications ports are supported, allowing serial and Ethernet connections to be used with external devices.

This product contains material licensed under the GNU General Public License Version 2.0 and the GNU Lesser General Public License Version 2.1.

Refer to Appendix A for licensing information.

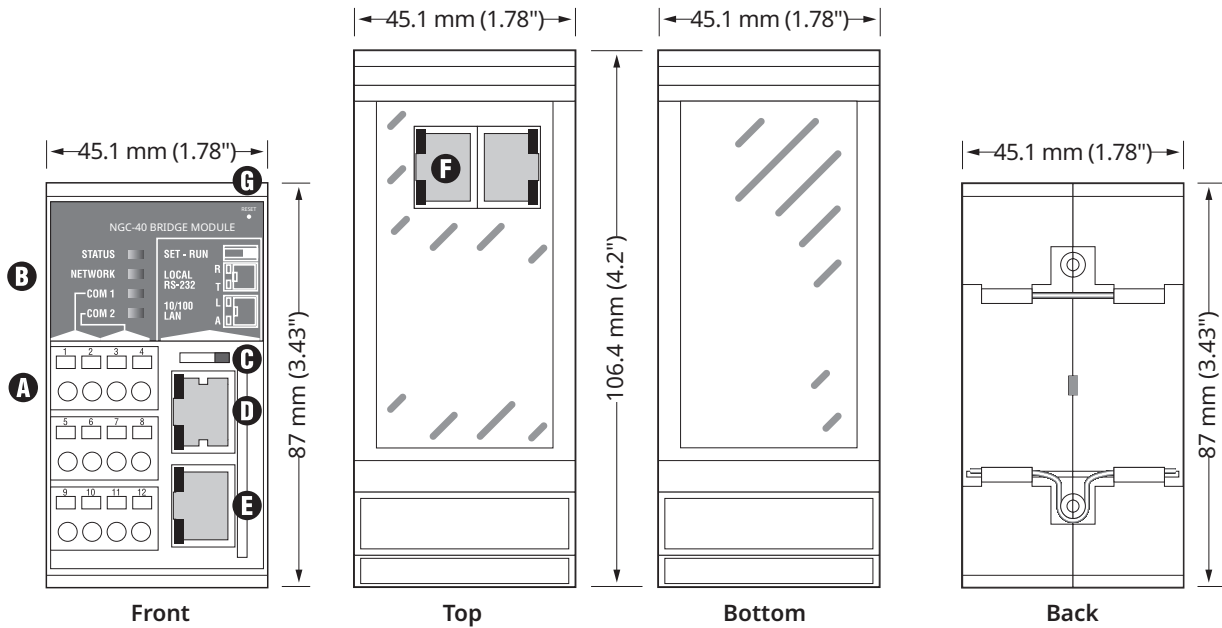

A. WIRING TERMINALS - RS-485 PORTS

1	COM 1 + in	4	COM 2 + out	7	COM 2 - in
2	COM 1 + out	5	COM 1 - in	8	COM 2 - out
3	COM 2 + in	6	COM 1 - out	9	Not used

B. STATUS LEDs

STATUS: Indicates status of the module
 Off No power
 Green OK/Normal
 Yellow (flashing) Configuration mode
 Red (flashing) Internal fault

NETWORK: Indicates CAN network activity
 Off No link detected
 Green Link OK, receive data packets
 Yellow Transmit data packets
 Red (flashing) Network error

COM: Indicates COM1 & 2 (RS-485) activity
 Off No activity
 Green (flashing) Receipt of data packet
 Yellow (flashing) Transmit of data packet

C. COMMUNICATION SLIDE SWITCH

D. RS-232 PORT

STATUS: Indicates status of RS-232 port

Top LED

Off No activity
 Green (flashing) Receipt of data packet

Bottom LED

Off No activity
 Yellow (flashing) Transmit of data packet

E. ETHERNET PORT

STATUS: Indicates status of the LAN

Top LED

Off No LAN detected
 Green ON, LAN detected

Bottom LED

Off No LAN activity
 Yellow (flashing) LAN activity (data packet)

F. CAN BUS / MODULE POWER

G. RESET BUTTON

General

Approvals and Certifications

Supply voltage	24 Vdc, ± 10%
Internal power consumption	< 3.6 W per NGC-40-BRIDGE
Ambient operating temperature	-40°C to 65°C (-40°F to 149°F)
Ambient storage temperature	-40°C to 75°C (-40°F to 167°F)
Environment	PD2, CAT III
Max. altitude	2,000 m
Humidity	5 - 90% noncondensing
Mounting	Din Rail - 35 mm

Electromagnetic Compatibility

Emissions	EN 61000-6-3 Emission standard for residential, commercial and light industrial environments
Immunity	EN 61000-6-2 Immunity standard for industrial environments

Communications COM1, COM2

Type	2-wire RS-485
Cable	One shielded twisted pair
Length	1,200 m (4,000 ft) maximum
Quantity	Up to 255 devices per port
Data rate	9600, 19.2K, 38.4K, 57.6K, 115.2K baud
Data bits	7 or 8
Parity	None, even, odd
Stop bits	0, 1, 2
Tx delay	0 - 5 sec.
Protocol	Modbus RTU or ASCII
Connection terminals	Wago cage clamp terminals

Communications COM1, COM2

Type	RS-232
Cable	Custom TTC# 10332-005
Length	15 m (50 ft) maximum
Data rate	9600, 19.2K, 38.4K, 57.6K, 115.2K baud
Data bits	7 or 8
Parity	None, even, odd
Stop bits	0, 1, 2
Tx delay	0 - 5 sec.
Protocol	Modbus RTU or ASCII
Connection terminals	RJ-11

CAN Networking Port	
Type	2-wire isolated CAN-based peer-peer network. Isolated to 300 V.
Connection	Two 8-pin RJ-45 connectors (both may be used for Input or Output connections)
Protocol	Proprietary NGC-40
Topology	Daisy chain
Length	10 m (33 ft) maximum
Quantity	Up to 80 CAN nodes per network segment
Address	Unique, factory assigned
Ethernet	
Type	10/100 BaseT Ethernet network
Length	100 m (328 ft)
Data rates	10 or 100 MB/s
Protocol	Modbus/TCP
Connection terminals	Shielded 8-pin RJ-45 connector on front of module
Programming and Setting	
LED indicators	
Alarm conditions	RESET, Configuration lost, CAN communications fail
Configuration switch	SET/RUN slide switch on front of module
Connection terminals	
Wiring terminals	Cage clamp, 0.5 to 2.5 mm ² (24 to 12 AWG)
CAN networking and module power	Two RJ-45s, one each IN and OUT. Provides CAN bus signals and +24 Vdc power.
Housing	
Size	45.1 mm (1.78 in) wide x 87 mm (3.43 in) high x 106.4 mm (4.2 in) deep

3.3 NGC-40-IO

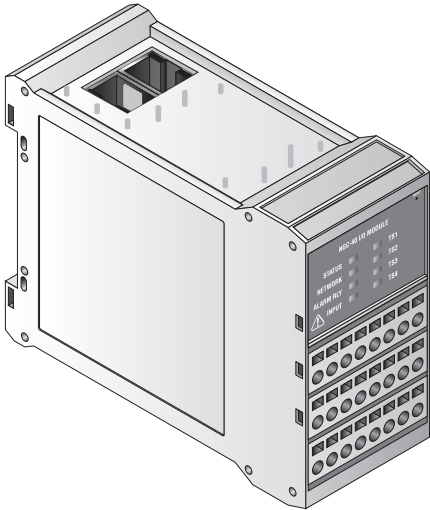

The NGC-40-IO provides up to four additional RTD inputs. These additional RTD inputs can be assigned to any NGC-40-HTC/HTC3. The NGC-40-IO also has one digital input and one alarm relay.

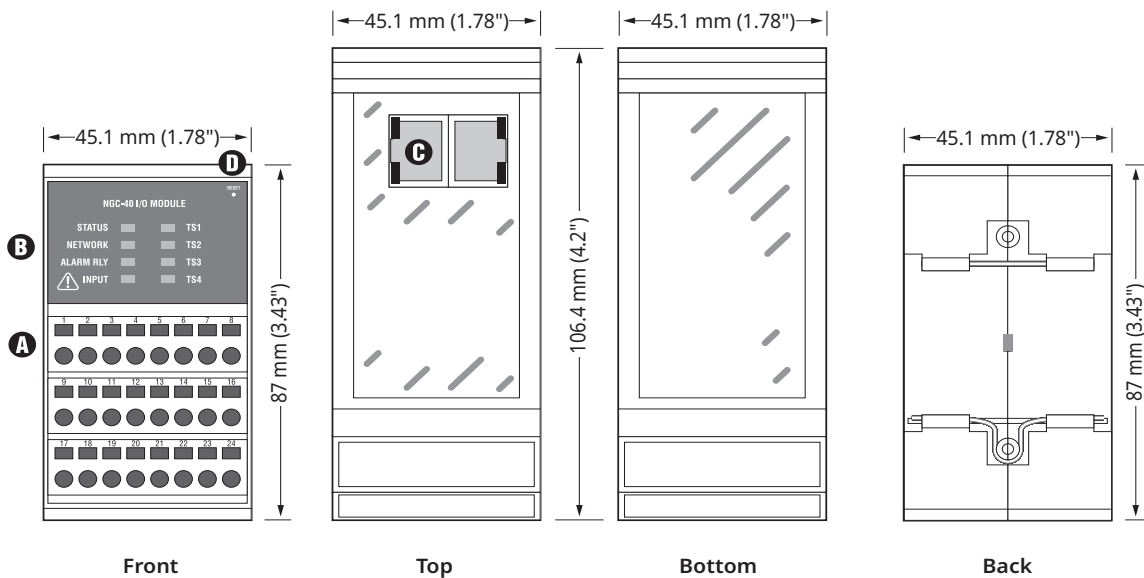

A. WIRING TERMINALS - RS-485 PORTS

1-3 ⚠	Alarm relay	9-12	TS1 (RTD1)	21-24	TS4 (RTD4)
4-6	Not used	13-16	TS2 (RTD2)	⚠ WARNING: Shock Hazard. Disconnect from live voltage prior to accessing terminals	
7-8	Digital input	17-20	TS3 (RTD3)		

B. STATUS LEDs

STATUS: Indicates status of IO module

Off	No power
Green	OK/Normal
Yellow	Configuration mode
Red	Internal fault

ALARM RELAY

Off	No alarm
Red	Alarm condition

TS1 FAIL to TS4 FAIL

Off	Normal, no fault
Red	TS fail (open, shorted, out of range)

NETWORK: Indicates CAN network activity

Off	No link detected
Green	Link OK, receive data packets
Yellow	Transmit data packets

INPUT: Shows status of digital input

Off	Input is inactive (open)
Green	Input is active (shorted)

GFI: Indicates ground-fault status

Off	No alarm
Red	High or low ground-fault alarm
Flash R	Ground-fault trip alarm

C. CAN BUS / MODULE POWER

D. RESET BUTTON

General

Approvals and Certifications	
Supply voltage	24 Vdc, ± 10%
Internal power consumption	< 2.4 W per NGC-40-IO
Ambient operating temperature	-40°C to 65°C (-40°F to 149°F)
Ambient storage temperature	-40°C to 75°C (-40°F to 167°F)
Environment	PD2, CAT III
Max. altitude	2,000 m (6,562 ft)
Humidity	5 – 90% noncondensing
Mounting	Din Rail – 35 mm

Electromagnetic Compatibility

Emissions	EN 61000-6-3 Emission standard for residential, commercial and light industrial environments
Immunity	EN 61000-6-2 Immunity standard for industrial environments

Temperature Sensors

Type	100 W, platinum RTD, 3-wire, $\alpha = 0.00385$ ohms/ohm/°C Can be extended with a 3-conductor shielded cable of 20 W maximum per conductor
	100 W, Ni-Fe, 2-wire Can be extended with a 2-wire shielded cable of 20 W maximum per conductor
Quantity	Up to four wired directly to each NGC-40-IO module

Alarm Relay

Dry contact relay (voltage free)	Relay contact rated 250 V / 3 A 50/60 Hz (CE) and 277 V / 3 A 50/60 Hz (cCSAus). Output is user programmable to flash. NO and NC contacts available.
----------------------------------	---

Digital Input

Multi-purpose input	Multi-purpose input for connection to external dry (voltage-free) contact or DC voltage. May be user programmable for: not used / force off / force on functions. It can be configured to be active open or active closed.
Max. input voltage	24 Vdc

CAN Networking Port

Type	2-wire isolated CAN-based peer to peer network. Isolated to 300 V.
Connection	Two 8-pin RJ-45 connectors (both may be used for Input or Output connections)
Protocol	Proprietary NGC-40
Topology	Daisy chain
Length	10 m (33 ft) maximum
Quantity	Quantity Up to 80 HTC/HTC3 and IO modules per network segment
Address	Unique, factory assigned

Connection terminals

Wiring terminals	Cage clamp, 0.5 to 2.5 mm ² (24 to 12 AWG)
CAN networking and module power	Two RJ-45s, one each IN and OUT. Provides CAN bus signals and +24 Vdc power.

Housing

Size	45.1 mm (1.78 in) wide x 87 mm (3.43 in) high x 106.4 mm (4.2 in) deep
------	--

3.4 NGC-40-PTM

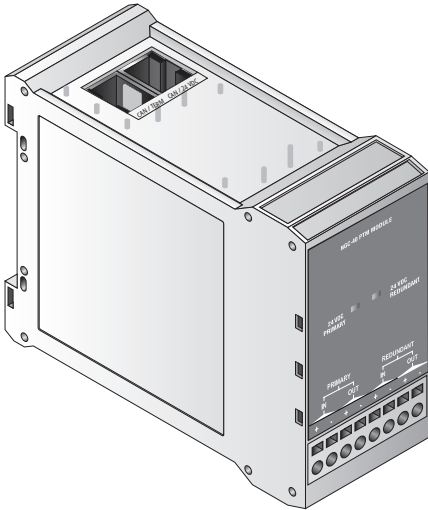

The NGC-40-PTM accepts a primary and redundant power supply input, accepts the CAN bus inputs, and provides for termination of the CAN bus. Each NGC-40-PTM can provide power for a maximum of 10 NGC-40 modules.

NGC-40-PTM System Components

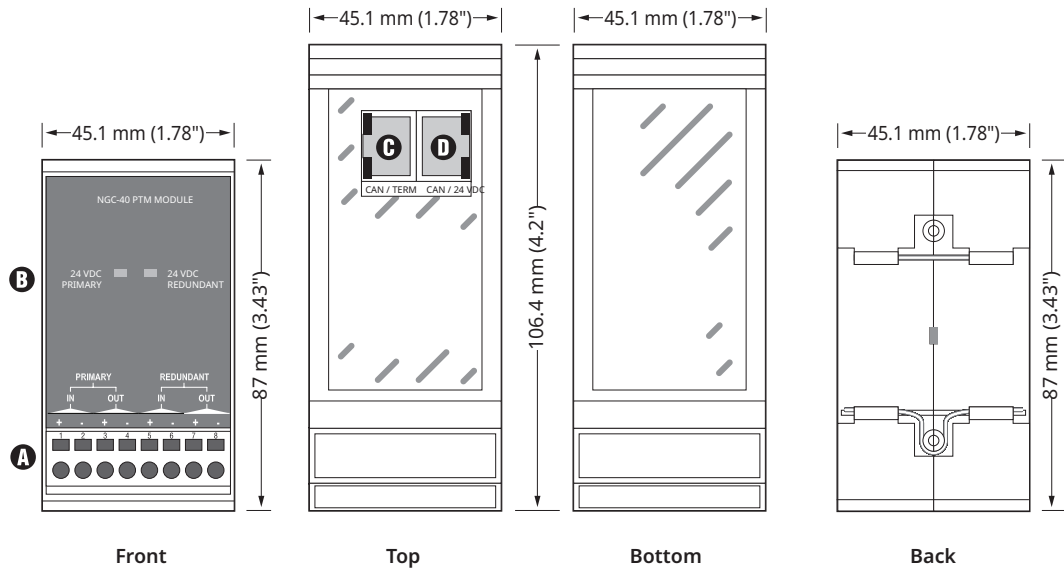

A. WIRING TERMINALS - RS-485 PORTS

1	Primary 24 Vdc In (+)	4	Primary 24 Vdc Out (-)	7	Redundant 24 Vdc Out (+)
2	Primary 24 Vdc In (-)	5	Redundant 24 Vdc In (+)	8	Redundant 24 Vdc Out (-)
3	Primary 24 Vdc Out (+)	6	Redundant 24 Vdc In (-)		

B. STATUS LEDs

STATUS:	24 Vdc Primary	24 Vdc Redundant
Off	No power	Off No power
Green	Power on	Green Power on

C. CAN/TERM

D. CAN/24 VDC

NGC-40-PTM Specifications

General

Approvals and Certifications

Supply voltage	24 Vdc, ± 10%
Internal power consumption	1 W per NGC-40-PTM
Output current	1.5 Amps @ 24 V
Ambient operating temperature	-40°C to 65°C (-40°F to 149°F)
Ambient storage temperature	-40°C to 75°C (-40°F to 167°F)
Environment	PD2, CAT III
Max. altitude	2,000 m (6,562 ft)
Humidity	5 - 90% noncondensing
Mounting	Din Rail - 35 mm

Electromagnetic Compatibility

Emissions	Residential/Commercial (Class B) Environment
-----------	--

CAN Networking Port

Type	2-wire isolated CAN-based peer to peer network. Isolated to 300 V.
Connection	Two 8-pin RJ-45 connectors (both may be used for Input or Output connections)
Topology	Daisy chain
Length	10 m (33 ft) maximum
Quantity	Up to 10 CAN nodes per PTM module

Connection terminals

Wiring terminals	Cage clamp, 0.5 to 2.5 mm ² (24 to 12 AWG)
CAN networking and module power	Two RJ-45s, one each IN and OUT. Provides CAN bus signals and 24 Vdc power.

Housing

Size	45.1 mm (1.78 in) wide x 87 mm (3.43 in) high x 106.4 mm (4.2 in) deep
------	--

System Power Supply Requirements

Output voltage	24 Vdc ±10%
Approval	NRTL approved device for use in nonhazardous or hazardous locations as appropriate
Overcurrent protection	Must have an automatic disconnect upon a single fault condition

Number of modules per power supply	Min. steady-state current rating (A)	Min. inrush current rating (A)	Min. size wire (AWG)
1 - 5	0.550	0.550	18
6 - 10	1.050	1.050	18
11 - 20	2.050	2.050	18

3.5 Touch 1500 and Touch 1500R Touch Screens



TOUCH 1500
installed in a panel

TOUCH 1500

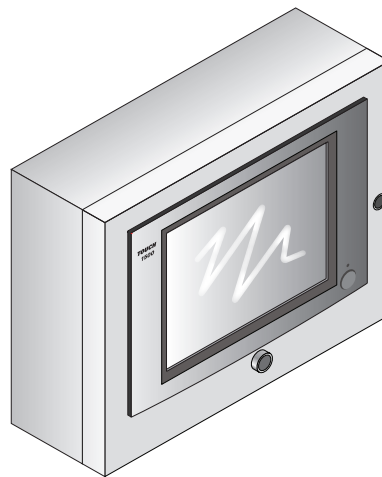

TOUCH 1500R

The Touch 1500 and Touch 1500R are panel mounted touch screen displays used in conjunction with Raychem NGC-40 and NGC-20 (Europe only) control and monitoring devices and are approved for nonhazardous indoor locations. The TOUCH 1500 is rated IP 65 (NEMA 4) and is intended to be mounted on the door of an NGC-40 panel containing NGC-40 modules. The Touch 1500R comes in an IP 65 (NEMA 4) wall-mounted enclosure and is intended to be mounted remotely from the NGC-40 panel containing the NGC-40 modules.

General

Touch 1500 Approvals / Certifications

Touch 1500R Approvals and Certifications

Area of use Nonhazardous, Indoors (IP65, TYPE 4)

Supply Voltage Touch 1500 120-240 VAC \pm 10% 50/60 Hz 96 VASupply Voltage Touch 1500R 120-240 VAC \pm 10% 50/60 Hz 96 VACurrent rating Steady state 1.8 A
Surge current 16 AOperating temperature 0°C to 50°C (32°F to 122°F) w/o space heater, -30°C to 50°C (-22°F to 122°F)
using space heater and screen cover

Storage temperature -20°C to 60°C (-4°F to 140°F)

Dimensions 449.9 mm W X 315.6 mm H X 141.7 mm D
(17.74 in. W X 12.44 in. H X 5.58 in. D)**Alarm Outputs**Relay output One Form C relay rated at 3 A @ 250 Vac.
Relay is used as a common alarm.

LCD Display

Display LCD is a 15-in XGA, color TFT transfective device with integral CCFL backlight

Touch Screen 4-wire resistive touch screen interface for user entry

Network ConnectionLocal/Remote Port * RS-232/RS-485 ports may be used to communicate with host computers DTS
(Raychem Supervisor Software) or DCS

Local RS-232 A non-isolated, 9 pin D sub male

Remote RS-485 2-wire isolated, 9 pin D sub male

Data rate 9600 to 57600 baud

Maximum cable length For RS-485 not to exceed 1200 m (4000 ft). Cable to be shielded twisted pair.

Field Port RS-485, 2-wire isolated. Used to communicate with external devices, such as
NGC-40-BRIDGE. Maximum cable length not to exceed 1200 m (4000 ft). Cable
to be shielded twisted pair.

Signals 2-wire isolated, 9 pin D sub male

Data rate To 9600 baud

LAN 10/100 Base-T Ethernet port with Link and Activity Status LEDs (X2)**USB Ports** USB 2.0 Host port Type A receptacle (X4)

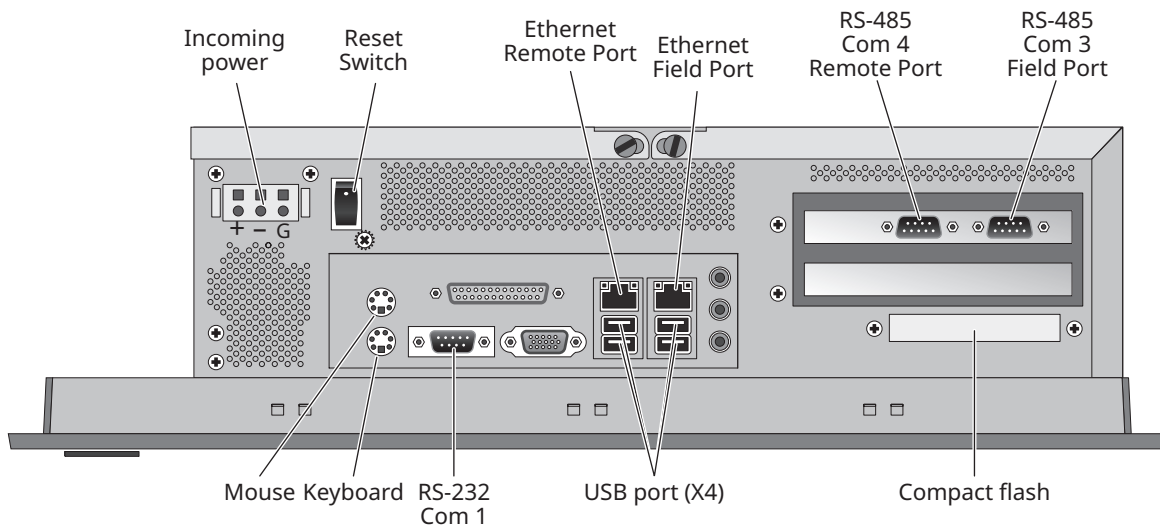

Fig. 2.23 Touch 1500 Connection Diagram

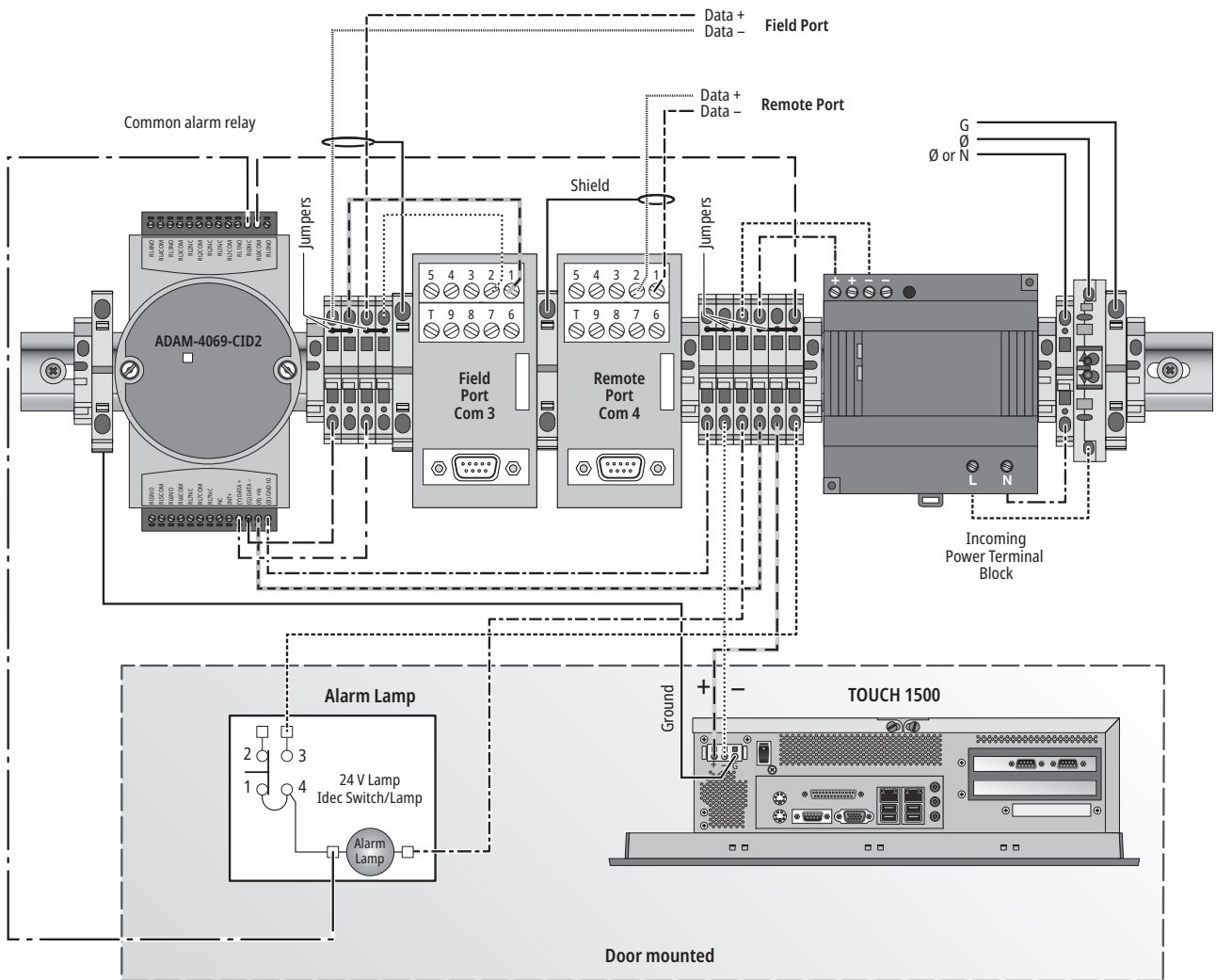

Fig. 2.24 Touch 1500 Overview of Wiring

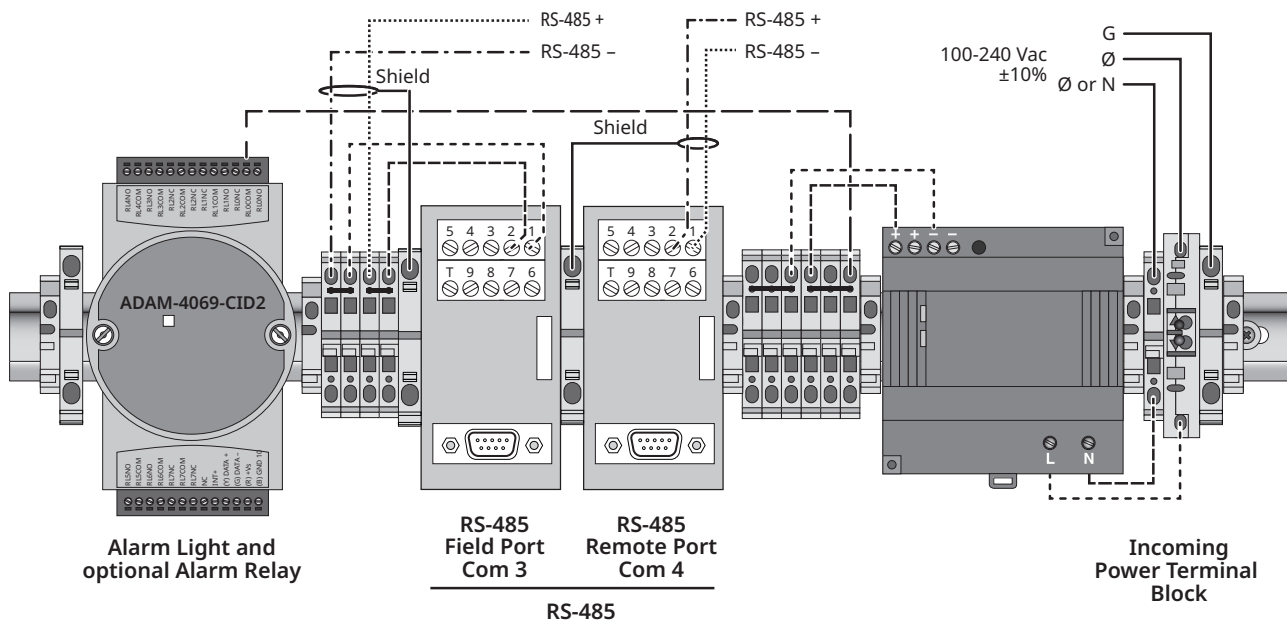

Fig. 2.25 Touch 1500R Overview of Wiring

3.6 Touch 1500-HAZ



Touch 1500-HAZ-CPU and
Touch 1500-HAZ-TS
installed in a panel

The Touch 1500-HAZ is a panel mounted touch screen display and computer used in conjunction with Raychem NGC-40 and NGC-20 (Europe only) control and monitoring devices. The Touch 1500-HAZ display is rated NEMA 4X (IP65) and can be mounted indoors or outdoors in a hazardous location. For outdoor installation, a space heater will be required in the panel for low ambient conditions.

General

Touch 1500-HAZ
Approvals and Certifications
Hazardous Locations
Class 1, Division 2 Groups A, B, C, D

Area of use	Nonhazardous or hazardous locations, indoor or outdoor (Type 4X, IP66)
Supply Voltage - Touch 1500-HAZ-CPU: Supply Voltage - Touch 1500-HAZ-TS:	10 – 36 Vdc 19 – 30 Vdc
Current rating - Touch 1500-HAZ-CPU: Current rating - Touch 1500-HAZ-TS:	2 A @ 24 Vdc 2.62 A @ 24 Vdc
Operating temp (CE)* - Touch 1500-HAZ-CPU: Operating temp (CE)* - Touch 1500-HAZ-TS:	-20°C to 60°C (-4°F to 140°F) -20°C to 60°C (-4°F to 140°F)
Operating temp (UL)* - Touch 1500-HAZ-CPU: Operating temp (UL)* - Touch 1500-HAZ-TS:	-10°C to 60°C (14°F to 140°F) 0°C to 50°C (32°F to 122°F)
Storage temperature	-30°C to 80°C (-22°F to 176°F)
Dimensions (W x D x H) Touch 1500-HAZ-CPU: Touch 1500-HAZ-TS:	85.5 mm x 139 mm x 152 mm (3.4 in x 5.5 in x 6 in) 422 mm x 68 mm x 338 mm (16.61 in x 2.68 in x 13.31 in)

Alarm Outputs

Relay output	One Form C relay rated at 12 A @ 250 Vac. Relay is used as a common alarm.
--------------	---

Network Connection

Remote Port	RS-485 port may be used to communicate with host computers DTS (Raychem Supervisor Software) or DCS
RS-485	A non-insulated 9 pin D sub male
Data rate	To 9600 to 57000 baud
Maximum cable length	For RS-485 not to exceed 1200 m (4000 ft). Cable to be shielded twisted pair.
Field Port	RS-485, 2-wire isolated. Used to communicate with external devices, such as NGC-40-BRIDGE. Maximum cable length not to exceed 1200 m (4000 ft). Cable to be shielded twisted pair.
RS-485	A non-insulated 9 pin D sub male
Data rate	To 9600 baud
Maximum cable length	For RS-485 not to exceed 1200 m (4000 ft). Cable to be shielded twisted pair
LAN	10/100 Base-T Ethernet port with Link and Activity Status LEDs (X3)
USB Ports	USB 2.0 host ports (X4)

Alarm Outputs

Display	LCD is a 15-in XGA, color TFT transfective device with integral LED backlighting.
Touch Screen	5-wire resistive touch screen interface with enhanced ITO film for user entry.



***IMPORTANT:** Temperature ratings are without space heaters

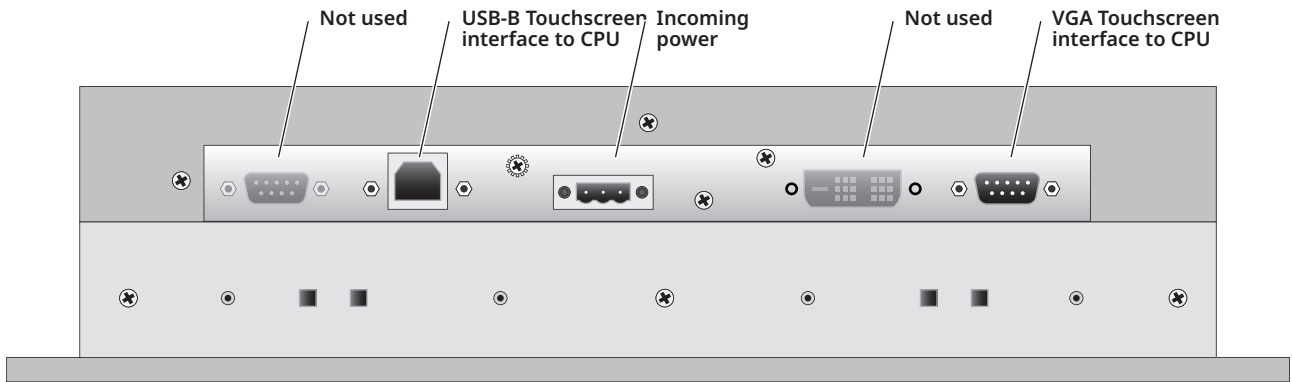

Fig. 2.26 Touch 1500-HAZ-TS Port Diagram

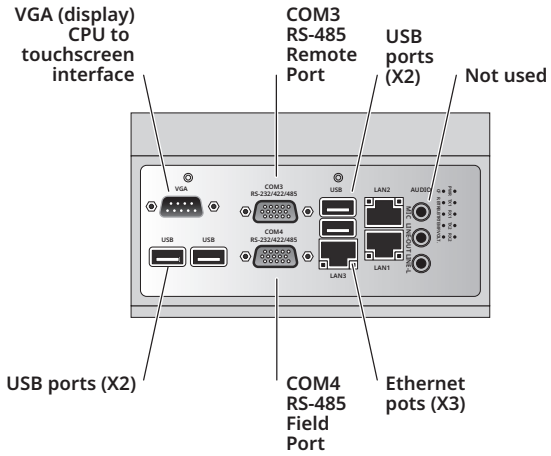

Fig. 2.27 Touch 1500-HAZ-CPU Port Diagram (Back View)

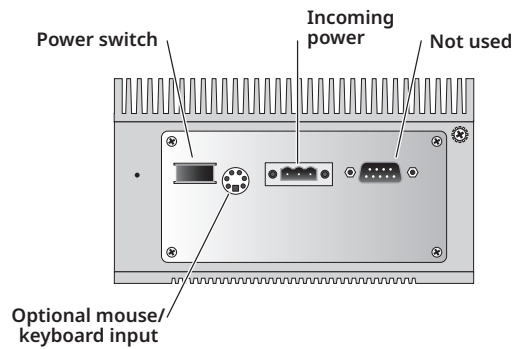

Fig. 2.28 Touch 1500-HAZ-CPU Port Diagram (Side View)

SECTION 4. APPENDIX A

4.1 Software License Agreement

The NGC-40 family of Heat-Tracing Controllers contains software, including firmware, created by Chemelex LLC and its suppliers. Some of these products may contain open source software. The software and firmware created by Chemelex LLC or its suppliers is licensed under the Chemelex NGC-40 Software License Agreement contained in Schedule 1 below.

The open source software is licensed under the GNU General Public License version 2.0 or the GNU General Public License version 2.1 provided in schedule 2 and 3 respectively. The source code for the open source software is available upon request from Chemelex Customer Service for three years from the purchase date of the product. Charges may apply.

4.1.1 SOFTWARE LICENSES

Schedule 1

Chemelex LLC

NGC-40 Software License Agreement

PLEASE REVIEW THE FOLLOWING TERMS AND CONDITIONS OF THIS SOFTWARE LICENSE AGREEMENT (THE "AGREEMENT") CAREFULLY. THIS IS A LEGAL AGREEMENT BETWEEN YOU, THE END USER, AND CHEMELEX, LLC ("CHEMELEX"). THE TERMS OF THIS AGREEMENT GOVERN YOUR USE OF THE NGC-40 SOFTWARE, THIRD PARTY SOFTWARE IF APPLICABLE, AND ANY ACCOMPANYING WRITTEN MATERIALS OR FILES (THE NGC-40 SOFTWARE, THIRD PARTY SOFTWARE, AS WELL AS ANY ACCOMPANYING WRITTEN MATERIALS OR FILES ARE COLLECTIVELY REFERRED TO IN THIS AGREEMENT AS THE "SOFTWARE"). BY INSTALLING, ACCESSING, OR OTHERWISE USING THE PRODUCT CONTAINING THE SOFTWARE, YOU ACKNOWLEDGE THAT YOU HAVE READ AND UNDERSTOOD ALL OF THE TERMS AND CONDITIONS OF THE AGREEMENT AND ARE AGREEING TO BE BOUND BY THE TERMS OF THIS AGREEMENT.

IF YOU DO NOT ACCEPT ALL OF THE TERMS AND CONDITIONS OF THIS AGREEMENT, DO NOT INSTALL, ACCESS, OR USE THE SOFTWARE. IF YOU ACQUIRED THE SOFTWARE ON TANGIBLE MEDIA (E.G., CD-ROM) OR SUPPLIED AS PART OF AN NGC-40 MODULE WITHOUT AN OPPORTUNITY TO REVIEW THIS AGREEMENT AND YOU DO NOT ACCEPT THIS AGREEMENT, YOU MAY OBTAIN A REFUND OF ANY AMOUNT YOU ORIGINALLY PAID FOR THE LICENSE PROVIDED YOU: (1) DO NOT INSTALL OR USE THE SOFTWARE; AND (2) RETURN THE SOFTWARE (OR, IF THE SOFTWARE WAS SUPPLIED AS PART OF AN NGC-40 MODULE, THE UNUSED PRODUCT) AND ALL OTHER ITEMS RECEIVED WITH THE DISK OR NGC-40 MODULE (INCLUDING WRITTEN MATERIALS, PACKAGING, ETC.) WITH PROOF OF PAYMENT TO THE PLACE WHERE YOU OBTAINED THEM, WITHIN THIRTY (30) DAYS OF THE PAYMENT DATE.

1. **GRANT OF LICENSE.** Subject to the terms and conditions of this Agreement, Chemelex grants to you a non-exclusive, nontransferable, limited license (without the right to sublicense others) to use the Software solely as embedded in an NGC-40 module.
2. **OWNERSHIP OF SOFTWARE; LICENSE FEE.** The Software is licensed, not sold, to you for use only under the terms and conditions of this Agreement. Your license confers no title or ownership in the Software and should not be construed as a sale of any rights in the Software. Chemelex shall retain all and sole right, title, and interest, including the copyright, in and to the Software. Chemelex reserves any rights not expressly granted herein.
3. **RESTRICTIONS.** The Software is protected by law, including without limitation the copyright laws of the United States and other countries and by international treaty provisions. The structure, organization and code of the Software are valuable trade secrets and confidential information of Chemelex. You agree not to modify, alter, merge, adapt, duplicate, distribute, translate, decompile, disassemble, reverse engineer, create derivative works, copy for use on any other computer or at any other location, or otherwise make this software available to any person or entity outside this location.

The Software is licensed only to you. In no event may you transfer, sell, sublicense, rent, assign or transfer rights, lease, or otherwise dispose of the Software on a temporary or permanent basis without the prior written consent of Chemelex. You agree to use reasonable efforts to protect against the unauthorized copying and use of the Software by others. You agree not to remove, disable or circumvent any proprietary notices or labels contained on or within the Software.

4. **SUBMISSIONS.** Chemelex welcomes your comments, feedback, and suggestions about how to improve the Software, or about any "bugs," defects, or seemingly incorrect or anomalous results discovered or produced through the use of the Software. However, you agree that by sending Chemelex any idea, suggestion, information, know-how, material, data, or any other content (collectively, "Submissions"), such Submissions become the property of Chemelex and the Chemelex may, at its option, use any Submission (or any modification or derivative thereof) without any obligation to you.

Should you have any questions or comments concerning the Software, this Agreement, or if you desire to contact Chemelex for any reason, please write to:

Chemelex LLC
15375 Memorial Drive Suite 1100
Houston, TX 77070
U.S.A.

5. **TERMINATION.** This Agreement is effective until terminated. You may terminate the license at any time by destroying the Software (including any and all related documentation and hardware). This license will terminate automatically without notice from Chemelex if you fail to comply with any provision of this Agreement. Upon termination of this Agreement for any reason, you agree to destroy all copies of the Software (including all hardware, written materials or files, if any).
6. **DISCLAIMER OF WARRANTY.** THE SOFTWARE (INCLUDING ANY ACCOMPANYING WRITTEN MATERIALS OR FILES) ARE PROVIDED "AS IS" AND "AS AVAILABLE." CHEMELEX DISCLAIMS ALL WARRANTIES, EXPRESS OR IMPLIED, OF ANY KIND, INCLUDING WITHOUT LIMITATION, WARRANTIES OF MERCHANTABILITY AND FITNESS FOR A PARTICULAR PURPOSE (EVEN IF CHEMELEX HAS BEEN ADVISED OF SUCH PURPOSE), TITLE, NON-INFRINGEMENT OR NON-MISAPPROPRIATION OF INTELLECTUAL PROPERTY RIGHTS OF A THIRD PARTY, CUSTOM, TRADE, QUIET ENJOYMENT, ACCURACY OF INFORMATIONAL CONTENT,

OR SYSTEM INTEGRATION. NO ORAL OR WRITTEN INFORMATION OR ADVICE GIVEN BY CHEMELEX OR ITS DEALERS, DISTRIBUTORS, OR AGENTS, SHALL CREATE SUCH A WARRANTY. CHEMELEX DOES NOT WARRANT THAT THE FUNCTIONS CONTAINED IN THE SOFTWARE WILL MEET YOUR REQUIREMENTS, OR THAT THE OPERATION OF THE SOFTWARE WILL BE UNINTERRUPTED OR ERROR-FREE, OR THAT THE SOFTWARE IS VIRUS-FREE, OR THAT PROGRAM DEFECTS WILL BE CORRECTED. CHEMELEX SHALL NOT BE RESPONSIBLE FOR PROBLEMS CAUSED BY THE INTERACTION OF THE SOFTWARE PRODUCT WITH NON-CHEMELEX SOFTWARE OR HARDWARE PRODUCTS. THIS AGREEMENT GIVES YOU SPECIFIC LEGAL RIGHTS. SOME STATES OR COUNTRIES DO NOT ALLOW THE EXCLUSION OF WARRANTIES SO THE ABOVE EXCLUSION MAY NOT APPLY TO YOU.

7. It is assumed that the user of the Software is expert in the engineering design of heat-tracing systems. Chemelex has not verified the results produced by the Software for all conceivable design or analysis cases, application scenarios, or system settings. You must judge the reasonableness of the results obtained by using your engineering expertise, and should independently evaluate the Software results before taking any action in reliance thereon. The entire risk as to the quality, accuracy, adequacy, completeness, correctness, suitability, and validity of the Software programs results rests with you.
8. **LIMITATION OF LIABILITY.** THE ENTIRE RISK AS TO THE RESULTS AND PERFORMANCE OF THE SOFTWARE IS ASSUMED BY YOU. IN NO EVENT SHALL Chemelex, ITS AFFILIATES, DIRECTORS, OFFICERS, SHAREHOLDERS, EMPLOYEES OR OTHER REPRESENTATIVES BE LIABLE FOR DAMAGES OF ANY KIND, INCLUDING WITHOUT LIMITATION, ANY LOSS, DAMAGE, OR DELAY, OR FOR ANY LOST PROFITS, LOSS OF USE, INTERRUPTION OF BUSINESS, OR FOR ANY COMPENSATORY, SPECIAL, INCIDENTAL, CONSEQUENTIAL, INDIRECT DAMAGES (HOWEVER ARISING, INCLUDING NEGLIGENCE) OF ANY KIND ARISING OUT OF OR IN CONNECTION WITH THE USE OF, OR THE INABILITY TO USE, THE SOFTWARE OR THIS AGREEMENT (EVEN IF CHEMELEX HAS BEEN ADVISED OF THE POSSIBILITY OF SUCH DAMAGES). FURTHER, IN NO EVENT SHALL CHEMELEX, ITS AFFILIATES, DIRECTORS, OFFICERS, SHAREHOLDERS, EMPLOYEES OR OTHER REPRESENTATIVES BE LIABLE TO YOU IN AN AMOUNT GREATER THAN THE AMOUNT ACTUALLY PAID BY YOU, IF ANY, FOR THE SOFTWARE. YOU FURTHER AGREE THAT REGARDLESS OF ANY STATUTE OR LAW TO THE CONTRARY, ANY CLAIM OR CAUSE OF ACTION ARISING OUT OF OR RELATED TO USE OF THE SOFTWARE OR THE TERMS AND CONDITIONS MUST BE FILED WITHIN ONE (1) YEAR AFTER SUCH CLAIM OR CAUSE OF ACTION AROSE OR BE FOREVER BARRED.
9. **INDEMNITY.** To the extent allowed under federal and state law, you agree to indemnify and hold Chemelex, its parents, subsidiaries, affiliates, officers, employees, sponsors and partners harmless from any claim, loss, cost, expense, demand, or damage, including reasonable attorneys' fees, arising directly or indirectly out of (a) your use of, or inability to use, the Software, (b) your activities in connection therewith, or (c) your breach of this Agreement or violation of the rights of any other party.
10. **COMPLETE AGREEMENT; MODIFICATION IN WRITING.** This Agreement constitutes the sole and complete understanding between the parties with respect to the Software and its use, and may not be varied except by a writing signed by an officer of Chemelex. You agree that you may not rely on any representations concerning the Software to the extent they vary from this Agreement, and such representations, if any, will neither add to nor vary the terms of this Agreement.
11. **CHOICE OF LAWS; JURISDICTION.** This Agreement is governed by the laws of the State of California and the United States, including U.S. Copyright Laws, regardless of the laws that might otherwise govern under applicable principles of conflicts of law. The parties hereby submit to the jurisdiction of, and waive any jurisdiction and venue objections against, the state and federal courts sitting in the State of California in any litigation arising under this Agreement.
12. **EXPORT LAWS.** If the Software is for use outside of the United States, you agree to comply fully with all relevant regulations of the United States Department of Commerce and with the United States Export Administration Act to ensure that the Software is not exported in violation of United States law. You agree that the Software will not be exported, shipped, transmitted, or re-exported in violation of any applicable law or regulation, including without limitation Export Administration regulations issued by the U.S. Department of Commerce, or any other export laws, restrictions or regulations (collectively, the "Export Laws"). In addition, if the Software is identified as an export-controlled item under the Export Laws, you represent and warrant that you are not a citizen, or otherwise located within, any U.S. embargoed nation and that you are not otherwise prohibited under the Export Laws from receiving the Software. All rights to use the Software are granted on condition that such rights are forfeited if you fail to comply with these Terms. You agree to indemnify Chemelex and assume all financial responsibility for any losses it may suffer if you do not comply with the terms of this Section 12.
13. **UNITED STATES GOVERNMENT RESTRICTED RIGHTS.** User acknowledges that the Software has been developed at private expense and is provided with "Restricted Rights." Use, duplication or disclosure by the Government is subject to restrictions as set forth in subparagraph (b) (3) and paragraph (c) of the Rights in Technical Data clause at 48 C.F.R. 252.227-7013, or subparagraphs (c)(1) and (2) of the Commercial Computer Software - Restricted Rights clause at 48 C.F.R. 52.227-19, as applicable or similar clauses in the NASA FAR Supplement. Contractor/manufacturer is Chemelex, LLC. This provision applies to the Software acquired directly or indirectly by or on behalf of any government. The Software is a commercial product, licensed on the open market at market prices, and was developed entirely at private expense and without the use of any government funds. Any use, modification, reproduction, release, performance, display, or disclosure of the Software by any government shall be governed solely by the terms of this Agreement and shall be prohibited except to the extent expressly permitted by the terms of this Agreement, and no license to the Software is granted to any government requiring different terms.
14. **ASSIGNMENT.** You may neither assign any right nor delegate any obligation under this Agreement and attempted assignment or delegation shall be void. Chemelex may freely assign this Agreement and its rights and obligations hereunder to any third party.
15. **INVALID PROVISIONS.** If any of the provisions of this provisions Agreement are invalid under any applicable statute or rule of law, the parties nevertheless agree that the court should endeavor to give effect to the parties' intentions as reflected in the provision and all other provisions remain in full force and effect.
16. **WAIVER.** No failure or delay of Chemelex in exercising or enforcing any right or provision of this Agreement shall constitute a waiver of such right or provision, or any other right or provision hereunder. Furthermore, any waiver by Chemelex of any right or provision of this Agreement shall not be construed as, or constitute, a continuing waiver of such right or provision, or waiver of any other right or provision of this Agreement.
17. **HEADINGS.** The section titles in this Agreement are for convenience only.
18. **SURVIVABILITY.** You agree that the terms and conditions of this Agreement shall survive any termination of this Agreement and your rights to use the Software.
19. **ACKNOWLEDGEMENT.** You hereby acknowledge that you have read this Agreement, understand it and agree to be bound by its terms and conditions.

Schedule 2

GNU GENERAL PUBLIC LICENSE

Version 2, June 1991

Copyright (C) 1989, 1991 Free Software Foundation, Inc., 51 Franklin Street, Fifth Floor, Boston, MA 02110-1301 USA

Everyone is permitted to copy and distribute verbatim copies of this license document, but changing it is not allowed.

Preamble

The licenses for most software are designed to take away your freedom to share and change it. By contrast, the GNU General Public License is intended to guarantee your freedom to share and change free software--to make sure the software is free for all its users. This General Public License applies to most of the Free Software Foundation's software and to any other program whose authors commit to using it. (Some other Free Software Foundation software is covered by the GNU Lesser General Public License instead.) You can apply it to your programs, too.

When we speak of free software, we are referring to freedom, not price. Our General Public Licenses are designed to make sure that you have the freedom to distribute copies of free software (and charge for this service if you wish), that you receive source code or can get it if you want it, that you can change the software or use pieces of it in new free programs; and that you know you can do these things.

To protect your rights, we need to make restrictions that forbid anyone to deny you these rights or to ask you to surrender the rights. These restrictions translate to certain responsibilities for you if you distribute copies of the software, or if you modify it. For example, if you distribute copies of such a program, whether gratis or for a fee, you must give the recipients all the rights that you have. You must make sure that they, too, receive or can get the source code. And you must show them these terms so they know their rights.

We protect your rights with two steps: (1) copyright the software, and (2) offer you this license which gives you legal permission to copy, distribute and/or modify the software. Also, for each author's protection and ours, we want to make certain that everyone understands that there is no warranty for this free software. If the software is modified by someone else and passed on, we want its recipients to know that what they have is not the original, so that any problems introduced by others will not reflect on the original authors' reputations.

Finally, any free program is threatened constantly by software patents. We wish to avoid the danger that redistributors of a free program will individually obtain patent licenses, in effect making the program proprietary. To prevent this, we have made it clear that any patent must be licensed for everyone's free use or not licensed at all.

The precise terms and conditions for copying, distribution and modification follow.

TERMS AND CONDITIONS FOR COPYING, DISTRIBUTION AND MODIFICATION

- This License applies to any program or other work which contains a notice placed by the copyright holder saying it may be distributed under the terms of this General Public License. The "Program", below, refers to any such program or work, and a "work based on the Program" means either the Program or any derivative work under copyright law: that is to say, a work containing the Program or a portion of it, either verbatim or with modifications and/or translated into another language. (Hereinafter, translation is included without limitation in the term "modification".) Each licensee is addressed as "you".

Activities other than copying, distribution and modification are not covered by this License; they are outside its scope. The act of running the Program is not restricted, and the output from the Program is covered only if its contents constitute a work based on the Program (independent of having been made by running the Program).

Whether that is true depends on what the Program does.

1. You may copy and distribute verbatim copies of the Program's source code as you receive it, in any medium, provided that you conspicuously and appropriately publish on each copy an appropriate copyright notice and disclaimer of warranty; keep intact all the notices that refer to this License and to the absence of any warranty; and give any other recipients of the Program a copy of this License along with the Program.
You may charge a fee for the physical act of transferring a copy, and you may at your option offer warranty protection in exchange for a fee.
2. You may modify your copy or copies of the Program or any portion of it, thus forming a work based on the Program, and copy and distribute such modifications or work under the terms of Section 1 above, provided that you also meet all of these conditions:
 - a. You must cause the modified files to carry prominent notices stating that you changed the files and the date of any change.
 - b. You must cause any work that you distribute or publish, that in whole or in part contains or is derived from the Program or any part thereof, to be licensed as a whole at no charge to all third parties under the terms of this License.
 - c. If the modified program normally reads commands interactively when run, you must cause it, when started running for such interactive use in the most ordinary way, to print or display an announcement including an appropriate copyright notice and a notice that there is no warranty (or else, saying that you provide a warranty) and that users may redistribute the program under these conditions, and telling the user how to view a copy of this License. (Exception: if the Program itself is interactive but does not normally print such an announcement, your work based on the Program is not required to print an announcement.)

These requirements apply to the modified work as a whole. If identifiable sections of that work are not derived from the Program, and can be reasonably considered independent and separate works in themselves, then this License, and its terms, do not apply to those sections when you distribute them as separate works. But when you distribute the same sections as part of a whole which is a work based on the Program, the distribution of the whole must be on the terms of this License, whose permissions for other licensees extend to the entire whole, and thus to each and every part regardless of who wrote it.

Thus, it is not the intent of this section to claim rights or contest your rights to work written entirely by you; rather, the intent is to exercise the right to control the distribution of derivative or collective works based on the Program.

In addition, mere aggregation of another work not based on the Program with the Program (or with a work based on the Program) on a volume of a storage or distribution medium does not bring the other work under the scope of this License.

3. You may copy and distribute the Program (or a work based on it, under Section 2) in object code or executable form under the terms of Sections 1 and 2 above provided that you also do one of the following:
 - a. Accompany it with the complete corresponding machine-readable source code, which must be distributed under the terms of Sections 1 and 2 above on a medium customarily used for software interchange; or,
 - b. Accompany it with a written offer, valid for at least three years, to give any third party, for a charge no more than your cost of physically performing source distribution, a complete machine-readable copy of the corresponding source code, to be distributed under the terms of Sections 1 and 2 above on a medium customarily used for software interchange; or,
 - c. Accompany it with the information you received as to the offer to distribute corresponding source code. (This alternative is allowed only for noncommercial distribution and only if you received the program in object code or executable form with such an offer, in accord with Subsection b above.)

The source code for a work means the preferred form of the work for making modifications to it. For an executable work, complete source code means all the source code for all modules it contains, plus any associated interface definition files, plus the scripts used to control compilation and installation of the executable. However, as a special exception, the source code distributed need not include anything that is normally distributed (in either source or binary form) with the major components (compiler, kernel, and so on) of the operating system on which the executable runs, unless that component itself accompanies the executable.

If distribution of executable or object code is made by offering access to copy from a designated place, then offering equivalent access to copy the source code from the same place counts as distribution of the source code, even though third parties are not compelled to copy the source along with the object code.

4. You may not copy, modify, sublicense, or distribute the Program except as expressly provided under this License. Any attempt otherwise to copy, modify, sublicense or distribute the Program is void, and will automatically terminate your rights under this License. However, parties who have received copies, or rights, from you under this License will not have their licenses terminated so long as such parties remain in full compliance.
5. You are not required to accept this License, since you have not signed it. However, nothing else grants you permission to modify or distribute the Program or its derivative works. These actions are prohibited by law if you do not accept this License. Therefore, by modifying or distributing the Program (or any work based on the Program), you indicate your acceptance of this License to do so, and all its terms and conditions for copying, distributing or modifying the Program or works based on it.
6. Each time you redistribute the Program (or any work based on the Program), the recipient automatically receives a license from the original licensor to copy, distribute or modify the Program subject to these terms and conditions. You may not impose any further restrictions on the recipients' exercise of the rights granted herein. You are not responsible for enforcing compliance by third parties to this License.
7. If, as a consequence of a court judgment or allegation of patent infringement or for any other reason (not limited to patent issues), conditions are imposed on you (whether by court order, agreement or otherwise) that contradict the conditions of this License, they do not excuse you from the conditions of this License. If you cannot distribute so as to satisfy simultaneously your obligations under this License and any other pertinent obligations, then as a consequence you may not distribute the Program at all. For example, if a patent license would not permit royalty-free redistribution of the Program by all those who receive copies directly or indirectly through you, then the only way you could satisfy both it and this License would be to refrain entirely from distribution of the Program.

If any portion of this section is held invalid or unenforceable under any particular circumstance, the balance of the section is intended to apply and the section as a whole is intended to apply in other circumstances.

It is not the purpose of this section to induce you to infringe any patents or other property right claims or to contest validity of any such claims; this section has the sole purpose of protecting the integrity of the free software distribution system, which is implemented by public license practices. Many people have made generous contributions to the wide range of software distributed through that system in reliance on consistent application of that system; it is up to the author/donor to decide if he or she is willing to distribute software through any other system and a licensee cannot impose that choice.

This section is intended to make thoroughly clear what is believed to be a consequence of the rest of this License.

8. If the distribution and/or use of the Program is restricted in certain countries either by patents or by copyrighted interfaces, the original copyright holder who places the Program under this License may add an explicit geographical distribution limitation excluding those countries, so that distribution is permitted only in or among countries not thus excluded. In such case, this License incorporates the limitation as if written in the body of this License.
9. The Free Software Foundation may publish revised and/or new versions of the General Public License from time to time. Such new versions will be similar in spirit to the present version, but may differ in detail to address new problems or concerns.
10. Each version is given a distinguishing version number. If the Program specifies a version number of this License which applies to it and "any later version", you have the option of following the terms and conditions either of that version or of any later version published by the Free Software Foundation. If the Program does not specify a version number of this License, you may choose any version ever published by the Free Software Foundation.

If you wish to incorporate parts of the Program into other free programs whose distribution conditions are different, write to the author to ask for permission. For software which is copyrighted by the Free Software Foundation, write to the Free Software Foundation; we sometimes make exceptions for this. Our decision will be guided by the two goals of preserving the free status of all derivatives of our free software and of promoting the sharing and reuse of software generally.

NO WARRANTY

11. BECAUSE THE PROGRAM IS LICENSED FREE OF CHARGE, THERE IS NO WARRANTY FOR THE PROGRAM, TO THE EXTENT PERMITTED BY APPLICABLE LAW. EXCEPT WHEN OTHERWISE STATED IN WRITING THE COPYRIGHT HOLDERS AND/OR OTHER PARTIES PROVIDE THE PROGRAM "AS IS" WITHOUT WARRANTY OF ANY KIND, EITHER EXPRESSED OR IMPLIED, INCLUDING, BUT NOT LIMITED TO, THE IMPLIED WARRANTIES OF MERCHANTABILITY AND FITNESS FOR A PARTICULAR PURPOSE. THE ENTIRE RISK AS TO THE QUALITY AND PERFORMANCE OF THE PROGRAM IS WITH YOU. SHOULD THE PROGRAM PROVE DEFECTIVE, YOU ASSUME THE COST OF ALL NECESSARY SERVICING, REPAIR OR CORRECTION.
12. IN NO EVENT UNLESS REQUIRED BY APPLICABLE LAW OR AGREED TO IN WRITING WILL ANY COPYRIGHT HOLDER, OR ANY OTHER PARTY WHO MAY MODIFY AND/OR REDISTRIBUTE THE PROGRAM AS PERMITTED ABOVE, BE LIABLE TO YOU FOR DAMAGES, INCLUDING ANY GENERAL, SPECIAL, INCIDENTAL OR CONSEQUENTIAL DAMAGES ARISING OUT OF THE USE OR INABILITY TO USE THE PROGRAM (INCLUDING BUT NOT LIMITED TO LOSS OF DATA OR DATA BEING RENDERED INACCURATE OR LOSSES SUSTAINED BY YOU OR THIRD PARTIES OR A FAILURE OF THE PROGRAM TO OPERATE WITH ANY OTHER PROGRAMS), EVEN IF SUCH HOLDER OR OTHER PARTY HAS BEEN ADVISED OF THE POSSIBILITY OF SUCH DAMAGES.

END OF TERMS AND CONDITIONS

Schedule 3

GNU LESSER GENERAL PUBLIC LICENSE

Version 2.1, February 1999

Copyright (C) 1991, 1999 Free Software Foundation, Inc. 51 Franklin Street, Fifth Floor, Boston, MA 02110-1301 USA

Everyone is permitted to copy and distribute verbatim copies of this license document, but changing it is not allowed.

[This is the first released version of the Lesser GPL. It also counts as the successor of the GNU Library Public License, version 2, hence the version number 2.1.]

Preamble

The licenses for most software are designed to take away your freedom to share and change it. By contrast, the GNU General Public Licenses are intended to guarantee your freedom to share and change free software--to make sure the software is free for all its users.

This license, the Lesser General Public License, applies to some specially designated software packages--typically libraries--of the Free Software Foundation and other authors who decide to use it. You can use it too, but we suggest you first think carefully about whether this license or the ordinary General Public License is the better strategy to use in any particular case, based on the explanations below.

When we speak of free software, we are referring to freedom of use, not price. Our General Public Licenses are designed to make sure that you have the freedom to distribute copies of free software (and charge for this service if you wish); that you receive source code or can get it if you want it; that you can change the software and use pieces of it in new free programs; and that you are informed that you can do these things.

To protect your rights, we need to make restrictions that forbid distributors to deny you these rights or to ask you to surrender these rights. These restrictions translate to certain responsibilities for you if you distribute copies of the library or if you modify it.

For example, if you distribute copies of the library, whether gratis or for a fee, you must give the recipients all the rights that we gave you. You must make sure that they, too, receive or can get the source code. If you link other code with the library, you must provide complete object files to the recipients, so that they can relink them with the library after making changes to the library and recompiling it. And you must show them these terms so they know their rights.

We protect your rights with a two-step method: (1) we copyright the library, and (2) we offer you this license, which gives you legal permission to copy, distribute and/or modify the library.

To protect each distributor, we want to make it very clear that there is no warranty for the free library. Also, if the library is modified by someone else and passed on, the recipients should know that what they have is not the original version, so that the original author's reputation will not be affected by problems that might be introduced by others.

Finally, software patents pose a constant threat to the existence of any free program. We wish to make sure that a company cannot effectively restrict the users of a free program by obtaining a restrictive license from a patent holder. Therefore, we insist that any patent license obtained for a version of the library must be consistent with the full freedom of use specified in this license.

Most GNU software, including some libraries, is covered by the ordinary GNU General Public License. This license, the GNU Lesser General Public License, applies to certain designated libraries, and is quite different from the ordinary General Public License.

We use this license for certain libraries in order to permit linking those libraries into non-free programs.

When a program is linked with a library, whether statically or using a shared library, the combination of the two is legally speaking a combined work, a derivative of the original library. The ordinary General Public License therefore permits such linking only if the entire combination fits its criteria of freedom. The Lesser General Public License permits more lax criteria for linking other code with the library.

We call this license the "Lesser" General Public License because it does Less to protect the user's freedom than the ordinary General Public License. It also provides other free software developers Less of an advantage over competing non-free programs. These disadvantages are the reason we use the ordinary General Public License for many libraries. However, the Lesser license provides advantages in certain special circumstances.

For example, on rare occasions, there may be a special need to encourage the widest possible use of a certain library, so that it becomes a de-facto standard. To achieve this, non-free programs must be allowed to use the library. A more frequent case is that a free library does the same job as widely used non-free libraries. In this case, there is little to gain by limiting the free library to free software only, so we use the Lesser General Public License.

In other cases, permission to use a particular library in non-free programs enables a greater number of people to use a large body of free software. For example, permission to use the GNU C Library in non-free programs enables many more people to use the whole

GNU operating system, as well as its variant, the GNU/Linux operating system. Although the Lesser General Public License is less protective of the users' freedom, it does ensure that the user of program that is linked with the Library has the freedom and the wherewithal to run that program using a modified version of the Library.

The precise terms and conditions for copying, distribution and modification follow. Pay close attention to the difference between a "work based on the library" and a "work that uses the library". The former contains code derived from the library, whereas the latter must be combined with the library in order to run.

TERMS AND CONDITIONS FOR COPYING, DISTRIBUTION AND MODIFICATION

- This License Agreement applies to any software library or other program which contains a notice placed by the copyright holder or other authorized party saying it may be distributed under the terms of this Lesser General Public License (also called "this License"). Each licensee is addressed as "you".

A "library" means a collection of software functions and/or data prepared so as to be conveniently linked with application programs (which use some of those functions and data) to form executables.

The "Library", below, refers to any such software library or work which has been distributed under these terms. A "work based on the Library" means either the Library or any derivative work under copyright law: that is to say, a work containing the Library or a portion of it, either verbatim or with modifications and/or translated straightforwardly into another language. (Hereinafter, translation is included without limitation in the term "modification".)

"Source code" for a work means the preferred form of the work for making modifications to it. For a library, complete source code means all the source code for all modules it contains, plus any associated interface definition files, plus the scripts used to control compilation and installation of the library.

Activities other than copying, distribution and modification are not covered by this License; they are outside its scope. The act of running a program using the Library is not restricted, and output from such a program is covered only if its contents constitute a work based on the Library (independent of the use of the Library in a tool for writing it). Whether that is true depends on what the Library does and what the program that uses the Library does.

1. You may copy and distribute verbatim copies of the Library's complete source code as you receive it, in any medium, provided that you conspicuously and appropriately publish on each copy an appropriate copyright notice and disclaimer of warranty; keep intact all the notices that refer to this License and to the absence of any warranty; and distribute a copy of this License along with the Library.

You may charge a fee for the physical act of transferring a copy, and you may at your option offer warranty protection in exchange for a fee.

2. You may modify your copy or copies of the Library or any portion of it, thus forming a work based on the Library, and copy and distribute such modifications or work under the terms of Section 1 above, provided that you also meet all of these conditions:
 - a. The modified work must itself be a software library.
 - b. You must cause the files modified to carry prominent notices stating that you changed the files and the date of any change.
 - c. You must cause the whole of the work to be licensed at no charge to all third parties under the terms of this License.
 - d. If a facility in the modified Library refers to a function or a table of data to be supplied by an application program that uses the facility, other than as an argument passed when the facility is invoked, then you must make a good faith effort to ensure that, in the event an application does not supply such function or table, the facility still operates, and performs whatever part of its purpose remains meaningful.

For example, a function in a library to compute square roots has a purpose that is entirely well-defined independent of the application. Therefore, Subsection 2d requires that any application-supplied function or table used by this function must be optional: if the application does not supply it, the square root function must still compute square roots.)

These requirements apply to the modified work as a whole. If identifiable sections of that work are not derived from the Library, and can be reasonably considered independent and separate works in themselves, then this License, and its terms, do not apply to those sections when you distribute them as separate works. But when you distribute the same sections as part of a whole which is a work based on the Library, the distribution of the whole must be on the terms of this License, whose permissions for other licensees extend to the entire whole, and thus to each and every part regardless of who wrote it.

Thus, it is not the intent of this section to claim rights or contest your rights to work written entirely by you; rather, the intent is to exercise the right to control the distribution of derivative or collective works based on the Library.

In addition, mere aggregation of another work not based on the Library with the Library (or with a work based on the Library) on a volume of a storage or distribution medium does not bring the other work under the scope of this License.

3. You may opt to apply the terms of the ordinary GNU General Public License instead of this License to a given copy of the Library. To do this, you must alter all the notices that refer to this License, so that they refer to the ordinary GNU General Public License, version 2, instead of to this License. (If a newer version than version 2 of the ordinary GNU General Public License has appeared, then you can specify that version instead if you wish.) Do not make any other change in these notices.

Once this change is made in a given copy, it is irreversible for that copy, so the ordinary GNU General Public License applies to all subsequent copies and derivative works made from that copy.

This option is useful when you wish to copy part of the code of the Library into a program that is not a library.

4. You may copy and distribute the Library (or a portion or derivative of it, under Section 2) in object code or executable form under the terms of Sections 1 and 2 above provided that you accompany it with the complete corresponding machine-readable source code, which must be distributed under the terms of Sections 1 and 2 above on a medium customarily used for software interchange.

If distribution of object code is made by offering access to copy from a designated place, then offering equivalent access to copy the source code from the same place satisfies the requirement to distribute the source code, even though third parties are not compelled to copy the source along with the object code.

5. A program that contains no derivative of any portion of the Library, but is designed to work with the Library by being compiled or linked with it, is called a “work that uses the Library”. Such a work, in isolation, is not a derivative work of the Library, and therefore falls outside the scope of this License.

However, linking a “work that uses the Library” with the Library creates an executable that is a derivative of the Library (because it contains portions of the Library), rather than a “work that uses the library”. The executable is therefore covered by this License. Section 6 states terms for distribution of such executables.

When a “work that uses the Library” uses material from a header file that is part of the Library, the object code for the work may be a derivative work of the Library even though the source code is not. Whether this is true is especially significant if the work can be linked without the Library, or if the work is itself a library. The threshold for this to be true is not precisely defined by law.

If such an object file uses only numerical parameters, data structure layouts and accessors, and small macros and small inline functions (ten lines or less in length), then the use of the object file is unrestricted, regardless of whether it is legally a derivative work. (Executables containing this object code plus portions of the Library will still fall under Section 6.)

Otherwise, if the work is a derivative of the Library, you may distribute the object code for the work under the terms of Section 6. Any executables containing that work also fall under Section 6, whether or not they are linked directly with the Library itself.

6. As an exception to the Sections above, you may also combine or link a “work that uses the Library” with the Library to produce a work containing portions of the Library, and distribute that work under terms of your choice, provided that the terms permit modification of the work for the customer's own use and reverse engineering for debugging such modifications.

You must give prominent notice with each copy of the work that the Library is used in it and that the Library and its use are covered by this License. You must supply a copy of this License. If the work during execution displays copyright notices, you must include the copyright notice for the Library among them, as well as a reference directing the user to the copy of this License. Also, you must do one of these things:

- a. Accompany the work with the complete corresponding machine-readable source code for the Library including whatever changes were used in the work (which must be distributed under Sections 1 and 2 above); and, if the work is an executable linked with the Library, with the complete machine-readable “work that uses the Library”, as object code and/or source code, so that the user can modify the Library and then relink to produce a modified executable containing the modified Library. (It is understood that the user who changes the contents of definitions files in the Library will not necessarily be able to recompile the application to use the modified definitions.)
- b. Use a suitable shared library mechanism for linking with the Library. A suitable mechanism is one that (1) uses at run time a copy of the library already present on the user's computer system, rather than copying library functions into the executable, and (2) will operate properly with a modified version of the library, if the user installs one, as long as the modified version is interface-compatible with the version that the work was made with.
- c. Accompany the work with a written offer, valid for at least three years, to give the same user the materials specified in Subsection 6a, above, for a charge no more than the cost of performing this distribution.
- d. If distribution of the work is made by offering access to copy from a designated place, offer equivalent access to copy the above specified materials from the same place.
- e. Verify that the user has already received a copy of these materials or that you have already sent this user a copy.

For an executable, the required form of the “work that uses the Library” must include any data and utility programs needed for reproducing the executable from it. However, as a special exception, the materials to be distributed need not include anything that is normally distributed (in either source or binary form) with the major components (compiler, kernel, and so on) of the operating system on which the executable runs, unless that component itself accompanies the executable.

It may happen that this requirement contradicts the license restrictions of other proprietary libraries that do not normally accompany the operating system. Such a contradiction means you cannot use both them and the Library together in an executable that you distribute.

7. You may place library facilities that are a work based on the Library side-by-side in a single library together with other library facilities not covered by this License, and distribute such a combined library, provided that the separate distribution of the work based on the Library and of the other library facilities is otherwise permitted, and provided that you do these two things:
 - a. Accompany the combined library with a copy of the same work based on the Library, uncombined with any other library facilities. This must be distributed under the terms of the Sections above.
 - b. Give prominent notice with the combined library of the fact that part of it is a work based on the Library, and explaining where to find the accompanying uncombined form of the same work.
8. You may not copy, modify, sublicense, link with, or distribute the Library except as expressly provided under this License. Any attempt otherwise to copy, modify, sublicense, link with, or distribute the Library is void, and will automatically terminate your rights under this License. However, parties who have received copies, or rights, from you under this License will not have their licenses terminated so long as such parties remain in full compliance.

9. You are not required to accept this License, since you have not signed it. However, nothing else grants you permission to modify or distribute the Library or its derivative works. These actions are prohibited by law if you do not accept this License. Therefore, by modifying or distributing the Library (or any work based on the Library), you indicate your acceptance of this License to do so, and all its terms and conditions for copying, distributing or modifying the Library or works based on it.
10. Each time you redistribute the Library (or any work based on the Library), the recipient automatically receives a license from the original licensor to copy, distribute, link with or modify the Library subject to these terms and conditions. You may not impose any further restrictions on the recipients' exercise of the rights granted herein. You are not responsible for enforcing compliance by third parties with this License.
11. If, as a consequence of a court judgment or allegation of patent infringement or for any other reason (not limited to patent issues), conditions are imposed on you (whether by court order, agreement or otherwise) that contradict the conditions of this License, they do not excuse you from the conditions of this License. If you cannot distribute so as to satisfy simultaneously your obligations under this License and any other pertinent obligations, then as a consequence you may not distribute the Library at all. For example, if a patent license would not permit royalty-free redistribution of the Library by all those who receive copies directly or indirectly through you, then the only way you could satisfy both it and this License would be to refrain entirely from distribution of the Library.

If any portion of this section is held invalid or unenforceable under any particular circumstance, the balance of the section is intended to apply, and the section as a whole is intended to apply in other circumstances.

It is not the purpose of this section to induce you to infringe any patents or other property right claims or to contest validity of any such claims; this section has the sole purpose of protecting the integrity of the free software distribution system which is implemented by public license practices. Many people have made generous contributions to the wide range of software distributed through that system in reliance on consistent application of that system; it is up to the author/donor to decide if he or she is willing to distribute software through any other system and a licensee cannot impose that choice.

This section is intended to make thoroughly clear what is believed to be a consequence of the rest of this License.

12. If the distribution and/or use of the Library is restricted in certain countries either by patents or by copyrighted interfaces, the original copyright holder who places the Library under this License may add an explicit geographical distribution limitation excluding those countries, so that distribution is permitted only in or among countries not thus excluded. In such case, this License incorporates the limitation as if written in the body of this License.
13. The Free Software Foundation may publish revised and/or new versions of the Lesser General Public License from time to time. Such new versions will be similar in spirit to the present version, but may differ in detail to address new problems or concerns. Each version is given a distinguishing version number. If the Library specifies a version number of this License which applies to it and "any later version", you have the option of following the terms and conditions either of that version or of any later version published by the Free Software Foundation. If the Library does not specify a license version number, you may choose any version ever published by the Free Software Foundation.
14. If you wish to incorporate parts of the Library into other free programs whose distribution conditions are incompatible with these, write to the author to ask for permission. For software which is copyrighted by the Free Software Foundation, write to the Free Software Foundation; we sometimes make exceptions for this. Our decision will be guided by the two goals of preserving the free status of all derivatives of our free software and of promoting the sharing and reuse of software generally.

NO WARRANTY

15. BECAUSE THE LIBRARY IS LICENSED FREE OF CHARGE, THERE IS NO WARRANTY FOR THE LIBRARY, TO THE EXTENT PERMITTED BY APPLICABLE LAW. EXCEPT WHEN OTHERWISE STATED IN WRITING THE COPYRIGHT HOLDERS AND/OR OTHER PARTIES PROVIDE THE LIBRARY "AS IS" WITHOUT WARRANTY OF ANY KIND, EITHER EXPRESSED OR IMPLIED, INCLUDING, BUT NOT LIMITED TO, THE IMPLIED WARRANTIES OF MERCHANTABILITY AND FITNESS FOR A PARTICULAR PURPOSE. THE ENTIRE RISK AS TO THE QUALITY AND PERFORMANCE OF THE LIBRARY IS WITH YOU. SHOULD THE LIBRARY PROVE DEFECTIVE, YOU ASSUME THE COST OF ALL NECESSARY SERVICING, REPAIR OR CORRECTION.
16. IN NO EVENT UNLESS REQUIRED BY APPLICABLE LAW OR AGREED TO IN WRITING WILL ANY COPYRIGHT HOLDER, OR ANY OTHER PARTY WHO MAY MODIFY AND/OR REDISTRIBUTE THE LIBRARY AS PERMITTED ABOVE, BE LIABLE TO YOU FOR DAMAGES, INCLUDING ANY GENERAL, SPECIAL, INCIDENTAL OR CONSEQUENTIAL DAMAGES ARISING OUT OF THE USE OR INABILITY TO USE THE LIBRARY (INCLUDING BUT NOT LIMITED TO LOSS OF DATA OR DATA BEING RENDERED INACCURATE OR LOSSES SUSTAINED BY YOU OR THIRD PARTIES OR A FAILURE OF THE LIBRARY TO OPERATE WITH ANY OTHER SOFTWARE), EVEN IF SUCH HOLDER OR OTHER PARTY HAS BEEN ADVISED OF THE POSSIBILITY OF SUCH DAMAGES.

END OF TERMS AND CONDITIONS

North America

Tel +1 800 545 6258
info@chemelex.com

Latin America

Tel +1 713 868 4800
info@chemelex.com

Europe, Middle East, Africa, India

Tel +32 16 213 511
Fax +32 16 213 604
info@chemelex.com

Asia Pacific

Tel +86 21 2412 1688
infoAPAC@chemelex.com

chemelex
excellence is everything

Raychem Tracer Pyrotenax Nuheat