

Stripping-Tool-Sr-Cable

Stripping Tool For Raychem Self-Regulating Cable Operating Instructions

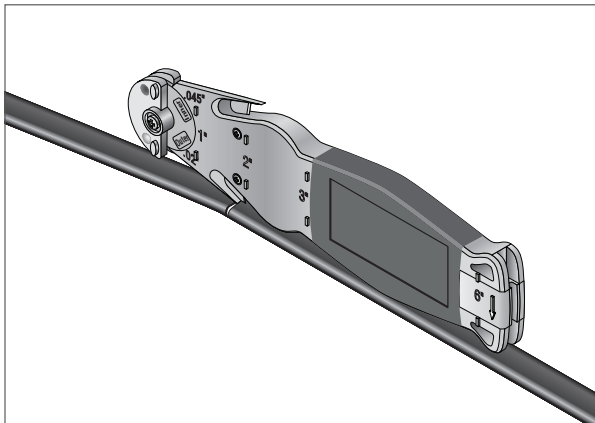

DESCRIPTION

The Raychem STRIPPING-TOOL-SR-CABLE is a cable stripping tool with no exposed or moving blades. This patent pending tool is designed for use with Raychem BTV-CR, BTV-CT, QTVR-CT, XTVR-CT, HWAT, XL-Trace, IceStop and RaySol self-regulating heat-tracing cables.

The tool has a robust metallic body, ergonomic contour and replaceable blades. The scoring blades are protected by a spring loaded cap that rotates automatically. For safety, the cap rotates back to its original position automatically after the cutting operation is performed.

The tool has two sets of blades designed for precise scoring of the outer and inner jackets of the cables mentioned above. The tool also includes a unique core scoring feature that prevents damage to the conductors. The tool also has ruler marks on it for measuring lengths during installations.

For technical support call Chemelex at (800) 545-6258.

TOOL DETAILS

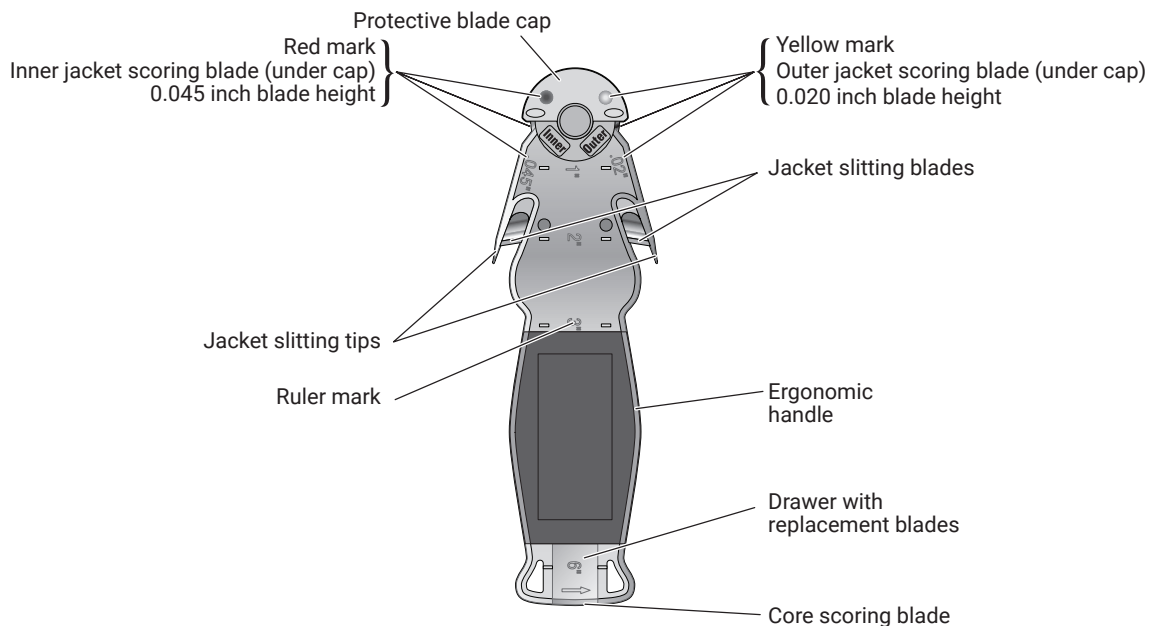

⚠ CAUTION: Cutting Hazard

The STRIPPING-TOOL-SR-CABLE has blades and sharp edges which can cause personal injury. The tool is a specialized stripping tool designed for Raychem self-regulating heat-tracing cables. Please familiarize yourself with the tool and read these operation instructions before using the tool.

The tool is only qualified to be used with Raychem BTV-CR, BTV-CT, QTVR-CT, XTVR-CT, HWAT, XL-Trace, IceStop and RaySol self-regulating heat-tracing cables. The tool may not work with other heat-tracing cables.

For more information please contact Chemelex at (800) 545-6258.

CABLE STRIPPING INSTRUCTIONS

All Raychem connection kits are provided with installation instructions which contain detailed steps for preparing cables for connections. The following instructions must be used in conjunction with the individual connection kit installation instructions to ensure proper installation.

TO STRIP OUTER JACKET

1

- Use the blade marked "Outer" to score around the outer jacket of the heating cable.

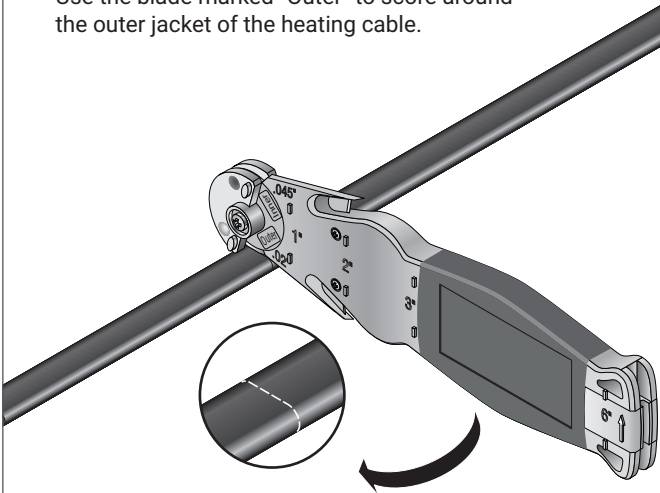

Note: Using the "Inner" blade to score outer jacket may cut the braid.

2

- Bend the heating cable at the score to separate the jacket.
- Insert the jacket slitting tip under the cable jacket.
- Pull the stripping tool towards the end of the heating cable to slit the jacket.

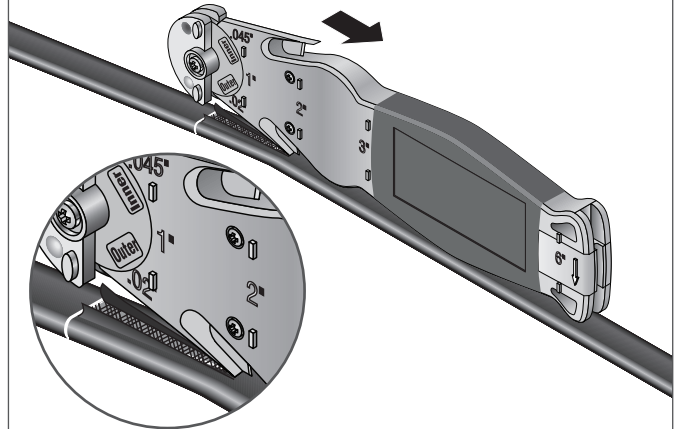

Note: Do not allow the jacket slitting tip to become wedged in the braid.

TO STRIP INNER JACKET

1

- Complete the braid preparation steps in the appropriate connection kit installation instructions.
- Use the blade marked "Inner" to score around the inner jacket of the heating cable.

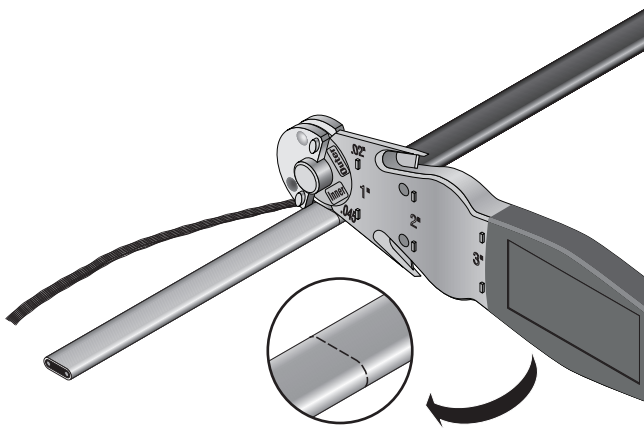

2

- Bend the heating cable at the score to separate the jacket.
- Insert the jacket slitting tip under the cable jacket.
- Pull the stripping tool towards the end of the heating cable to slit the jacket.

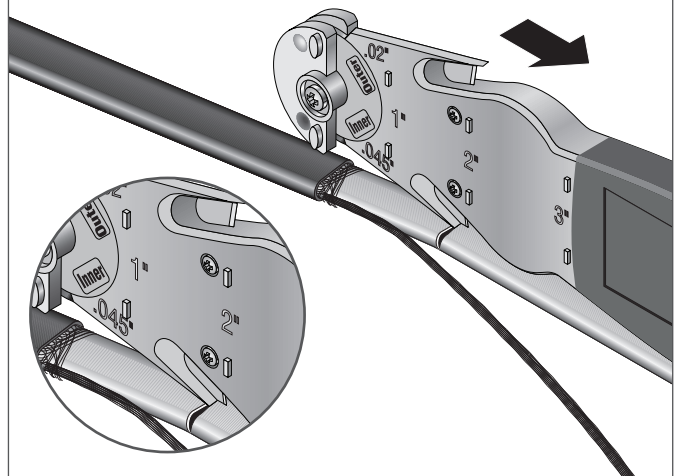

TO STRIP CORE

1

- Carefully notch the end of the cable with the diagonal cutter without cutting the bus wires.

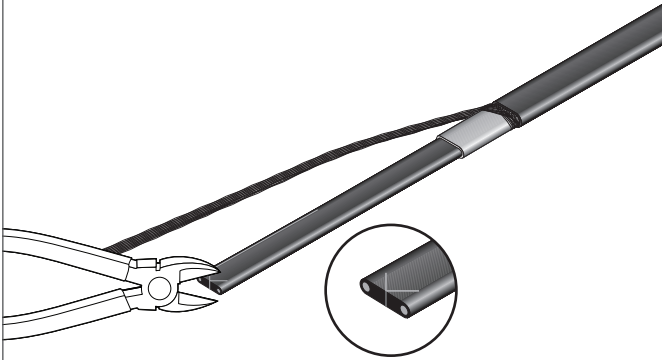

Note: For XTVR-CT, use the diagonal cutter to remove the fiber.

2

- Beginning at the end of the inner jacket and following the directional arrow, score along both edges of the core with the core stripping end of the tool.

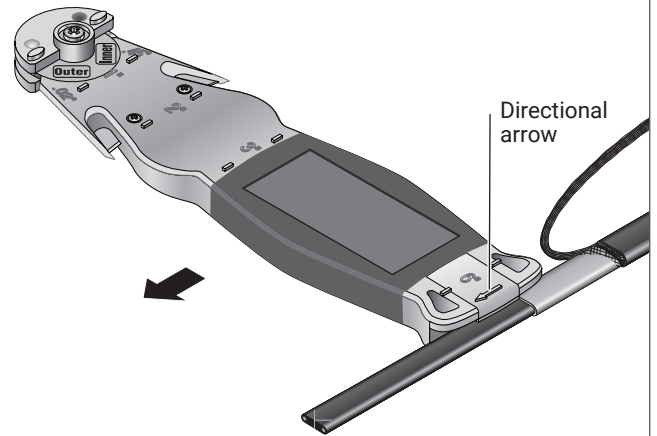

3

- Pull out bus wires with needle nose pliers as shown.

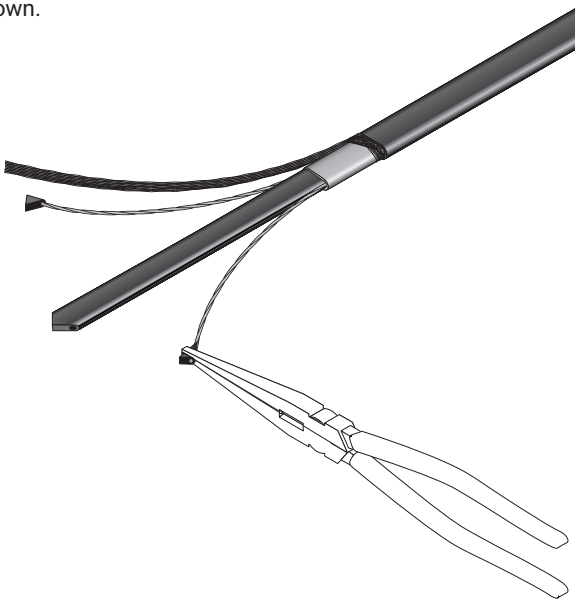

4

- Use the diagonal cutter to cut away the core and remove any remaining polymer at the end of the bus wires.

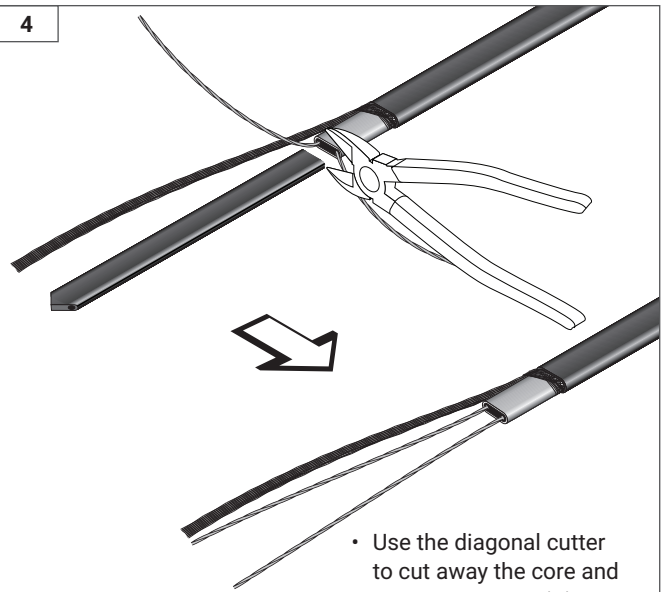

REPLACING JACKET SCORING BLADES AND JACKET SLITTING BLADES

1

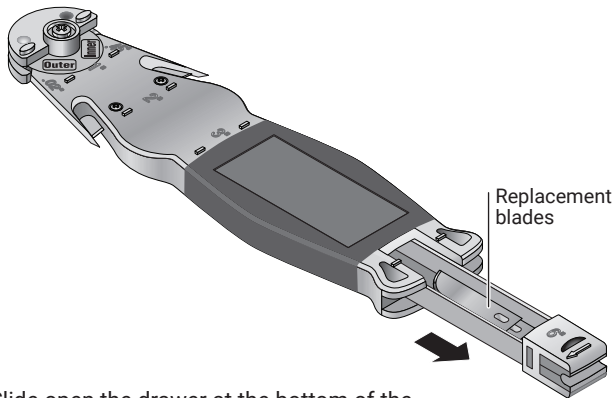

- Slide open the drawer at the bottom of the tool to locate the replacement blades.

Jacket scoring blade
(Techni Edge #10 Hobby blade TE01-103)

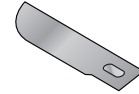

Jacket slitting blade (2 segments)
(Techni Edge 3/8 inch 13 point blade TE01-333)

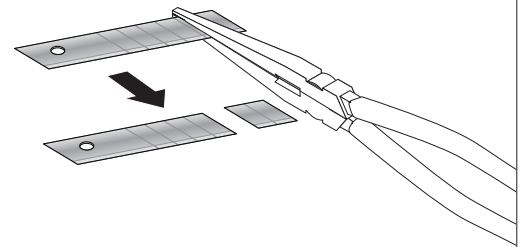

2

- Remove the screw on the blade cap with a #3 Phillips screwdriver.

- Carefully remove the springs and each half of the blade cap.

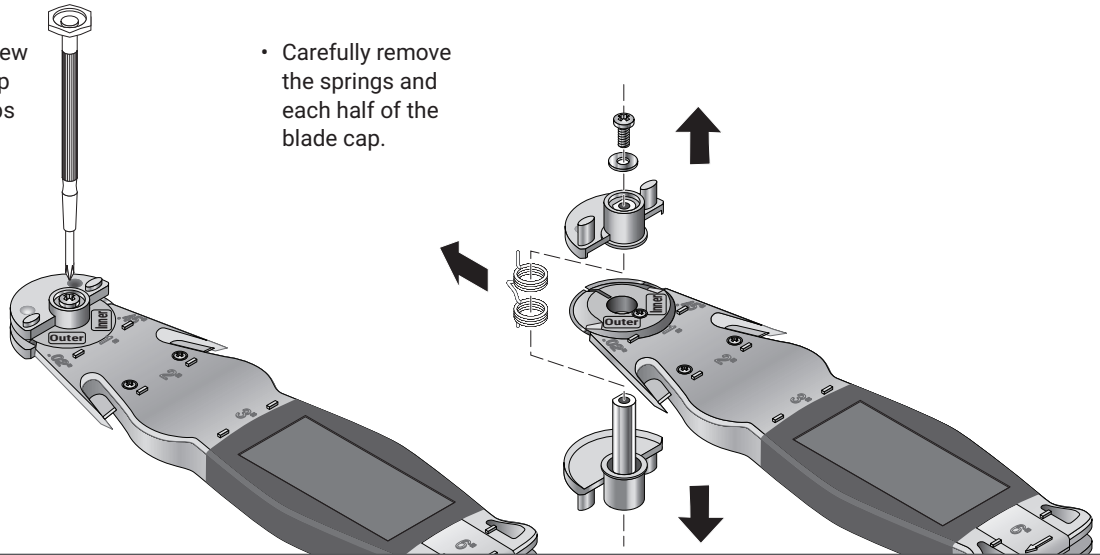

3

- Remove the remaining 3 screws on the tool with the #3 Phillips screwdriver.

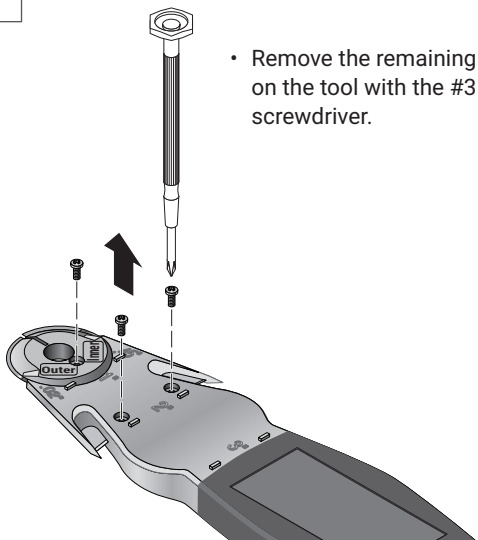

4

- Remove the cover and replace the blades.

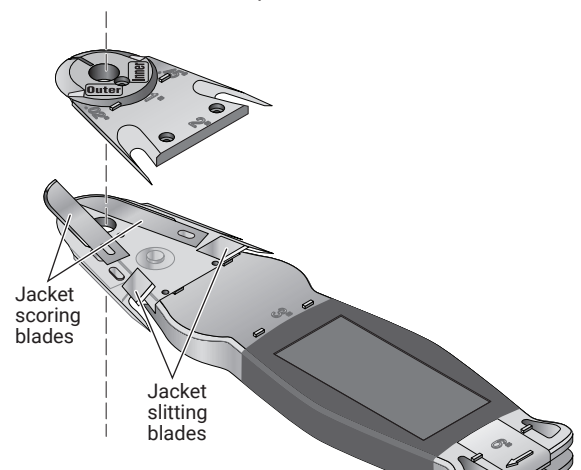

REPLACING THE CORE STRIPPING BLADE

1

- Slide open the drawer at the bottom of the tool to locate the replacement blades.

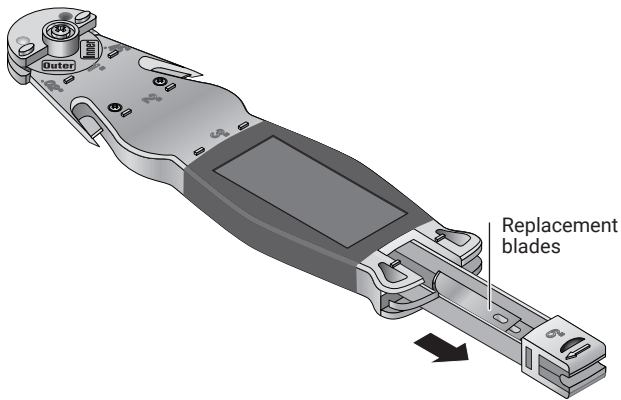

2

- Slide the core stripper out of the drawer.

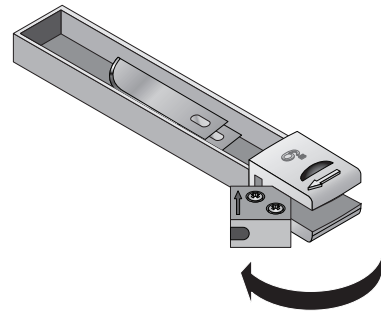

3

- Remove the core stripper screws with a #3 Phillips screwdriver.

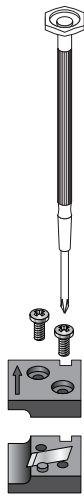

4

- Carefully remove one section of the replacement rectangular blade with pliers.

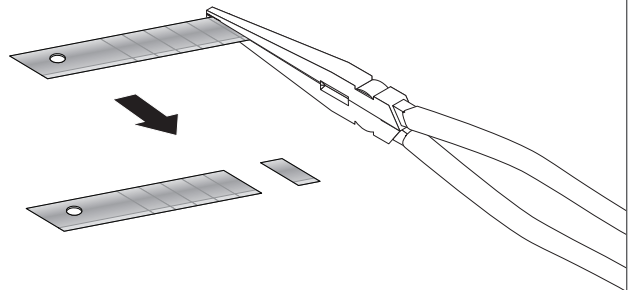

5

- Replace the core stripping blade.
- Reassemble all parts of the tool after the blades are replaced.

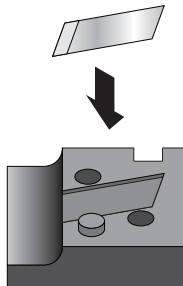

North America

Tel +1 800 545 6258
info@chemelex.com

Latin America

Tel +1 713 868 4800
info@chemelex.com

Europe, Middle East, Africa, India

Tel +32 16 213 511
Fax +32 16 213 604
info@chemelex.com

Asia Pacific

Tel +86 21 2412 1688
infoAPAC@chemelex.com

chemelex
excellence is everything

Raychem

Tracer

Pyrotenax

Nuheat