

Raychem

E-100-LR-A E-100-LR-E

Light Replacement and Retrofit Kit for High-Profile End Seal Installation Instructions

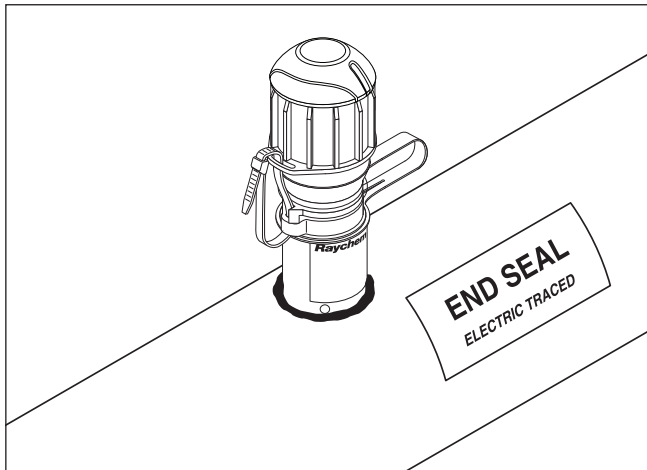

DESCRIPTION

The Raychem E-100-LR-A and E-100-LR-E light kit is used to replace the light on an E-100-L high-profile lighted end seal or to retrofit a light to an existing E-100 high-profile end seal.

This kit may be installed at temperatures as low as -40°F (-40°C). For easier installation store above freezing until just before installation.

- E-100-LR-E kit is used for E-100-E and E-100-L-E kits
- E-100-LR-A kit is used for E-100-A and E-100-L-A kits

For technical support call Chemelex at (800) 545-6258.

TOOLS REQUIRED

- Wire cutters
- Utility knife
- Marker
- Panduit CT-100 crimp tool or equivalent
- Rags or dry towel
- Wire strippers
- Needle nose pliers

APPROVALS

Hazardous Locations



Class I, Div. 2, Groups A, B, C, D
Class II, Div. 1 and 2, Groups E, F, G
Class III

CL I, ZN1, AEx e mb IIC T* Gb⁽¹⁾
ZN21 AEx tb IIIC T*
Ex e mb IIC T* Gb
Ex tb IIIC T***C Db
IECEX SIR 14.0007X
Ex e mb IIC T* Gb IP66
Ex tb IIIC T***C Db

sira

⁽¹⁾ Except VPL

* For system Temperature Code, see heating cable or design documentation.

KIT CONTENTS

Item	Qty	Description
A	1	Light assembly
B	1	Core sealer (for BTV, QTVR, XTV, and KTV)
C	2	Insulated butt splices (red)
D	2	Insulated parallel crimps (blue)
E	1	Cable tie

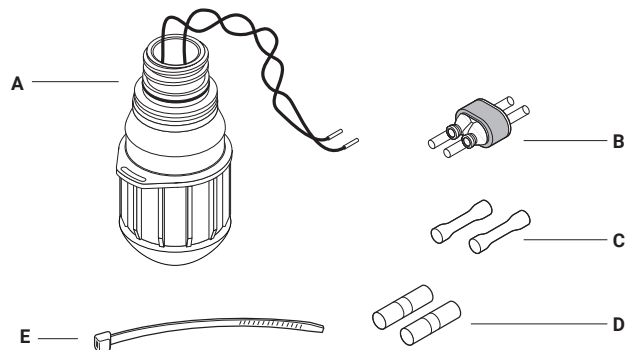

⚠ WARNING:

This component is an electrical device that must be installed correctly to ensure proper operation and to prevent shock or fire. Read these important warnings and carefully follow all of the installation instructions.

- To minimize the danger of fire from sustained electrical arcing if the heating cable is damaged or improperly installed, and to comply with the requirements of Chemelex, agency certifications, and the National Electrical Code, ground-fault equipment protection must be used. Arcing may not be stopped by conventional circuit breakers.
- Component approvals and performance are based on the use of Chemelex-specified parts only. Do not use substitute parts or

vinyl electrical tape.

- The black heating cable core and fibers are conductive and can short. They must be properly insulated and kept dry.
- Damaged bus wires can overheat or short. Do not break bus wire strands when scoring the jacket or core.
- Keep components and heating cable ends dry before and during installation.
- Bus wires will short if they contact each other. Keep bus wires separated.
- Use only fire-resistant insulation materials, such as fiberglass wrap or flame-retardant foam.
- Leave these installation instructions with the user for future use.

⚠ CAUTION:

Health Hazard: Prolonged or repeated contact with the sealant in the core sealer may cause skin irritation. Wash hands thoroughly. Overheating or burning the sealant will produce fumes that may cause polymer fume fever. Avoid contamination of cigarettes or tobacco. Consult MSDS VEN 0058 for further information.

CHEMTREC 24-hour emergency telephone:
(800) 424-9300.

Non-emergency health and safety information:
(800) 545-6258.

HEATING CABLE TYPES

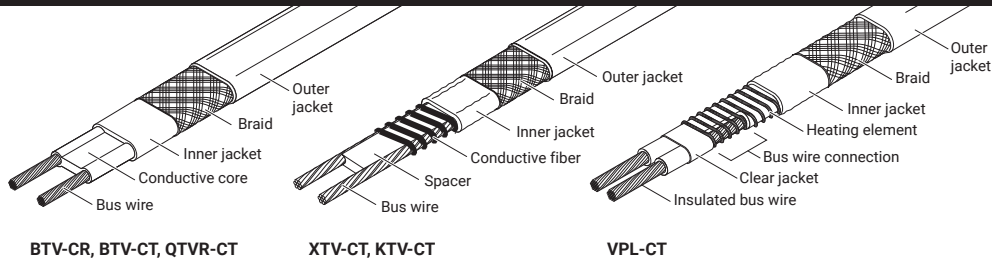

Light Replacement
Go to Step A (page 6)

Light Retrofit
Go to Step 1

1 BEGIN HERE FOR LIGHT RETROFIT.

⚠ WARNING: Shock Hazard. Electrical conductors will be exposed. Re-entry should only be performed by qualified personnel. Turn off power and follow standard electrical lockout procedures before opening end seal.

- Turn off power.
- Clip cable tie and remove.
- Unscrew cap from end seal stand.
- Remove cap from yellow leash.

2

⚠ CAUTION: Health Hazard. Wash hands if you contact sealant. Consult MSDS VEN 0058.

- Remove and discard boot.
- Using a dry towel, clean sealant from end of heating cable.

3

BTV, QTVR Go to Step 4A

XTV, KTV Go to Step 4A

VPL Go to Step 4B

4A

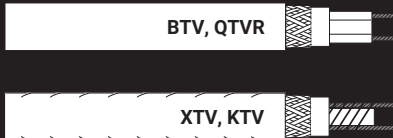

- Ensure 1 1/4 in (32 mm) of heating cable is exposed above end seal strain relief.

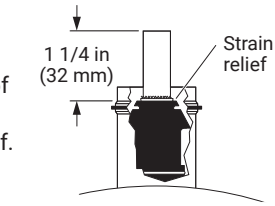

- Mark heating cable jacket.

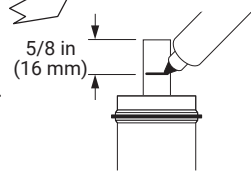

- Lightly score jacket around and up as shown.



- Peel off jacket.

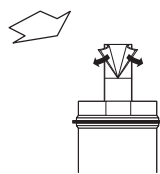

- Determine heating cable type and continue as shown.

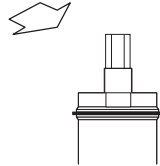

BTV, QTVR **Go to Step 5a**

XTV, KTV **Go to Step 5b**

4B



- Ensure 1 1/8 in (28 mm) of heating cable is exposed above end seal strain relief. The conductor should remain staggered.

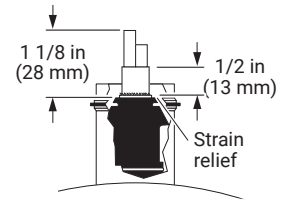

- Lightly score jacket around and up as shown.

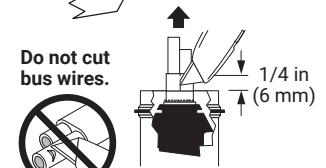

- Peel off jacket.

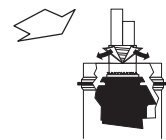

- Unwind heating element, cut and remove as shown.

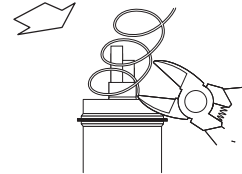

- Lightly score clear jacket around and up as shown.

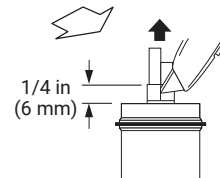

- Peel off jacket.

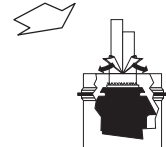

- Remove insulation from ends of bus wires.

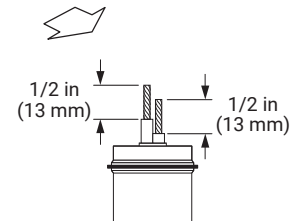

Note: Core sealer is not used on VPL. Discard core sealer.

Skip Step 5 and go to Step 6

5A

BTV, QTVR



- Notch core.

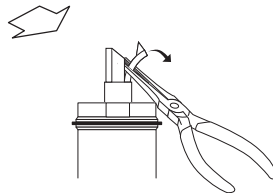

- Peel bus wire from core.

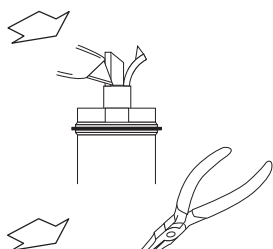

- Score core between bus wires at jacket.

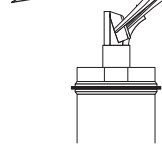

- Bend and snap core.

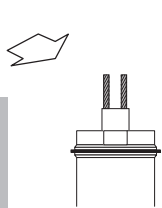

- Peel core from bus wires.
- Remove any remaining core material from bus wires.

CAUTION: Health Hazard.
Wash hands if you contact sealant. Consult MSDS VEN 0058.

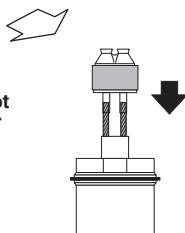

- If needed, retwist and straighten bus wires.
- Insert bus wires into guide tubes as shown.
- Slide core sealer onto heating cable.

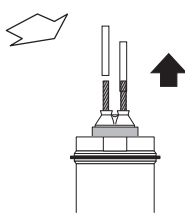

- Remove the guide tubes and dispose of them in a plastic bag.

Go to Step 6

5B

XTV, KTV

- Cut and remove all fiber material.



- Score and remove center spacer.
- Remove any remaining core material from bus wires.

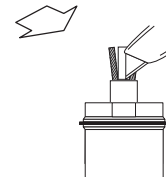

CAUTION: Health Hazard.
Wash hands if you contact sealant. Consult MSDS VEN 0058.

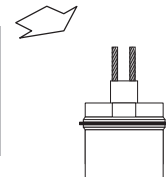

- If needed, retwist and straighten bus wires.

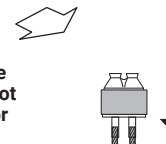

- Insert bus wires into guide tubes as shown.
- Slide core sealer onto heating cable.

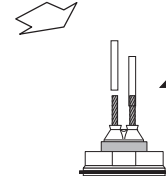
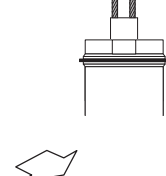

- Remove the guide tubes and dispose of them in a plastic bag.

Go to Step 6

6

- Install new light assembly into leash.
- Place blue crimps onto bus wires.

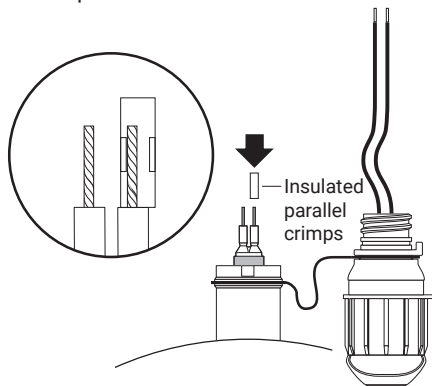

- Crimp bus wires to lead wires.

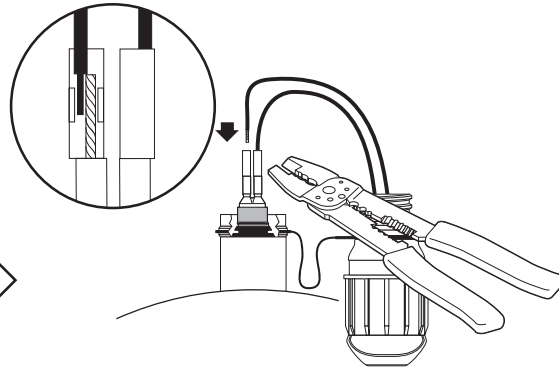

7

- Push excess wire inside light.

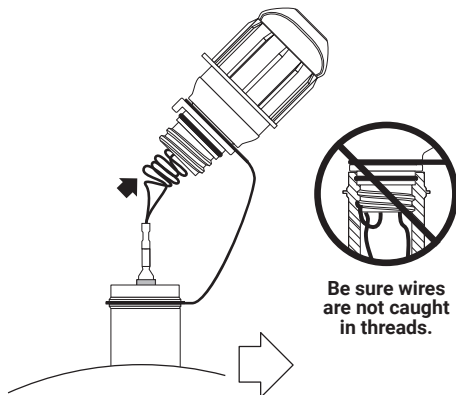

- Hand tighten light onto end seal stand.
- Insert cable tie through slots on stand and light then tighten.

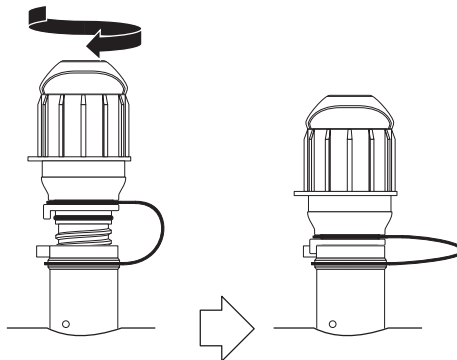

8

- Leave these instructions with the end user for future reference.

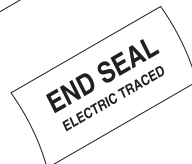
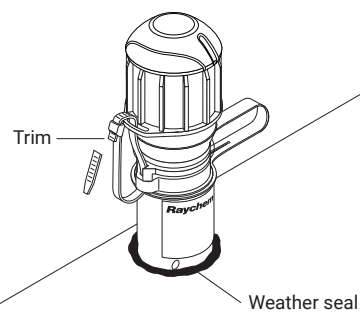

Go to Page 8

A BEGIN HERE FOR LIGHT REPLACEMENT

⚠ WARNING: Shock hazard. Electrical conductors will be exposed. Re-entry should only be performed by qualified personnel. Turn off power and follow standard electrical lockout procedures before opening end seal.

Note: The existing light shown in the instructions may look different from the existing light in your installation.

On existing light:

- Cut cable tie (if present).
- Unscrew light.
- Pull excess wire from inside light.

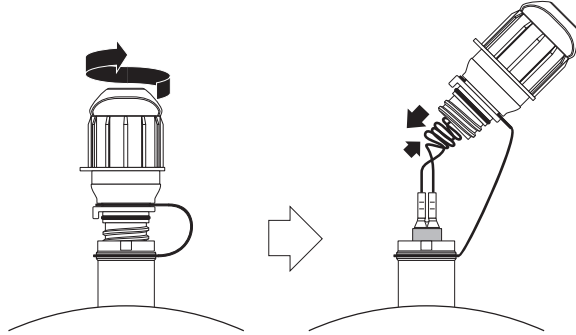

B

- Cut existing wires approximately 2 in (50 mm) above top of crimps or core sealer.
- Remove old light from yellow leash.

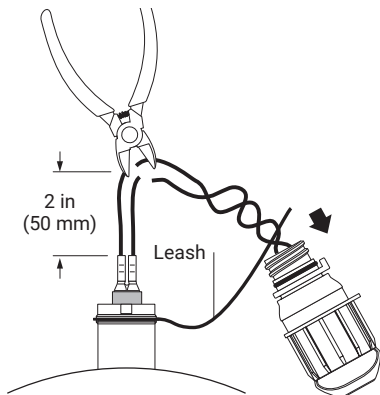

C

- Install new light into yellow leash.

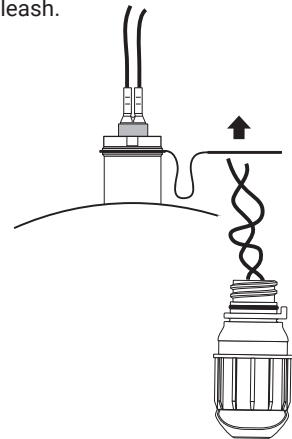

D

- Use 20 AWG wire stripper to remove insulation from each of the four wire ends.

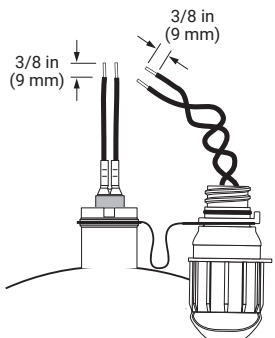

E

- Use Panduit CT-100 crimp tool and red insulated butt splices to crimp new wires to old wires.

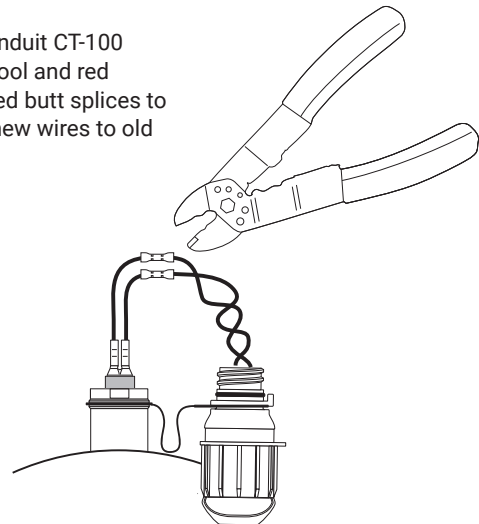

F

- Push excess wire inside light.

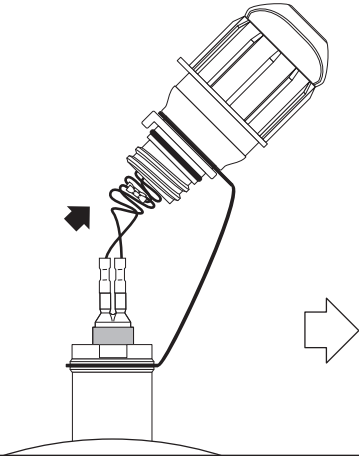

- Hand tighten light onto end seal stand.
- Insert cable tie through slots on stand and light then tighten.

Be sure wires are not caught in threads.

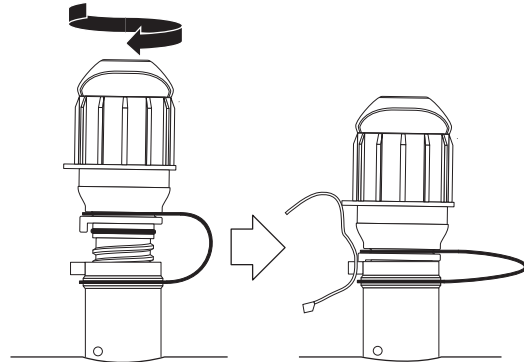

G

- Leave these instructions with the end user for future reference.

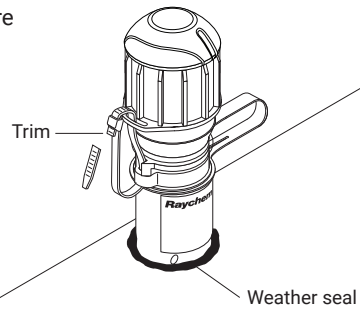

Go to Page 8

Troubleshooting Guide

Problem	Troubleshooting steps
Light is dim or off.	<ol style="list-style-type: none">1. Check that light voltage rating matches supply voltage for heat-tracing circuit. Supply voltage lower or higher than light rating will cause malfunctions.2. Check that heat-tracing circuit is energized. Although the circuit breaker is on, control devices such as thermostats may switch heating cable off.3. Following electrical safety procedures, disconnect supply voltage, unscrew light from end seal base and check that crimp connections to heating cable bus wires are tight and not crossed or shorted. Loose connections or shorts will cause malfunctions.4. With circuit off, attach volt meter leads to crimps. Energize circuit and measure voltage at light. Use the following table to determine whether the voltage measured is within the acceptable range of 100-305 Vac.<ul style="list-style-type: none">• If voltage at light is in acceptable range and connections are good, the light may be defective or damaged. Replace light.• If there is no voltage at the light, there may be breaks in the heating cable between the power connection and the end seal. Check for splice or tee connections that may be left open.• If voltage at light is above specified limits, the light may be off. Voltages above specified range can damage light. Replace light with correct version for line supply voltage or adjust supply voltage accordingly.• If voltage at light is present but below specified limits, the light may be dim or off. The following table lists typical causes for low voltages and possible solutions.

Cause	Solution
Supply voltage at start of circuit is low (light is designed to work with supply voltages within 10% of nominal).	Increase power wire gauge size to reduce voltage drop between panel and heating cable power connection.
Heating cable length is too long (light is designed to work with published maximum circuit lengths).	Split heating cable into multiple circuits. Shorten length of heating cable.
Heating cable is started under very cold conditions (heating-cable voltage drop is very high for first minutes of very cold start-up).	Wait for heating cable to warm up. Voltage at light will increase.
Heating cable controller is reducing voltage (light may not work with controllers that phase fire to reduce line voltage).	Turn off phase firing function in heating cable controller.

Problem	Troubleshooting steps
Cap cannot be tightened completely.	<ol style="list-style-type: none">1. Check that heating cable is installed and stripped correctly. The top of the insulated parallel crimps should be 2 3/8 in (60 mm), or less, above the top of the plastic strain relief in the stand.2. Check that core sealer is positioned properly. The end of the core sealer must be flush against the plastic strain relief in the stand.3. Check that the threads on the light and stand are clean. The connection wires between the heating cable and the light should not be caught in stand threads.

North America

Tel +1 800 545 6258
info@chemelex.com

Latin America

Tel +1 713 868 4800
info@chemelex.com

Europe, Middle East, Africa, India

Tel +32 16 213 511
Fax +32 16 213 604
info@chemelex.com

Asia Pacific

Tel +86 21 2412 1688
infoAPAC@chemelex.com

chemelex
excellence is everything

Raychem Tracer Pyrotenax Nuheat