

NGC-40-SLIM

Safety temperature limiter for use
with Raychem NGC-40 System

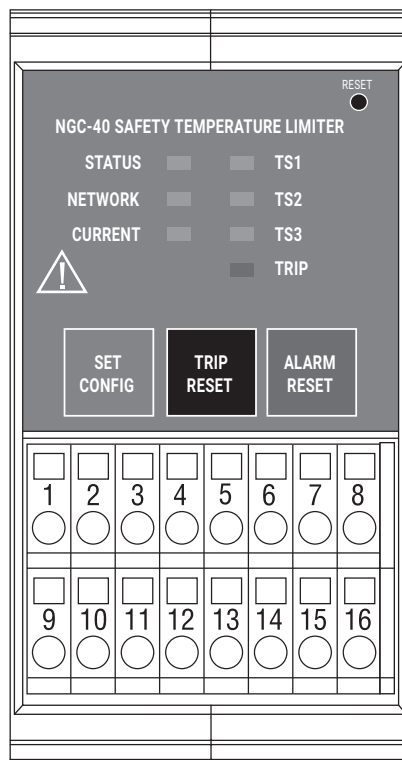

Contents

1	Introduction	3
1.1	Certification	3
1.2	Warranty	3
1.3	Limitation of warranty	3
1.4	Exclusive remedies	3
1.5	Statement of compliance	3
1.6	Area of use	4
1.7	Safety instructions	4
1.8	Conformity with standards	4
1.9	Approvals and certifications	5
2	Technical data	5
2.1	Product Description	5
2.1.1	Tools Required	5
2.1.2	Additional Materials required	5
2.1.3	Kit Contents	5
2.1.4	General information	5
2.1.5	Measuring range	5
2.1.6	Electromagnetic Compatibility	6
2.1.6.1	Emissions	6
2.1.6.2	Immunity	6
2.1.7	Temperature Sensors	6
2.1.8	Alarm Relay	6
2.1.9	Contactors Output Relay	6
2.1.10	Digital Input	6
2.1.11	CAN Networking Port	6
2.1.12	Connection terminals	6
2.1.13	NGC-40 Safety Limiter	6
2.1.14	NGC-40-SLIM accessories and associated components	6
2.1.15	Dimensions	7
2.2	Mounting and wiring NGC-40-SLIM module	8
3	Safety instructions for NGC-40-SLIM	13
3.1	Area of use	13
3.2	Safety function of temperature limiter in NGC-40-SLIM	13
3.3	Temperature limiter (schematic)	13
3.4	Reset Safety Temperature Limiter	14
3.5	Temperature setting secured and locked to prevent manipulation	14
3.6	Changing limiter set point	14
3.7	Procedure to write new temperature set point to limiter	14
3.8	Test in the event of a fault	14
3.9	Safety related system characteristics	15

1 INTRODUCTION

Please read all instructional literature carefully and thoroughly before starting. Refer to the inside front cover for the listing of Liabilities and Warranties.

NOTICE: The information contained in this document is subject to change without notice. Please read these Operating Instructions before commissioning the instrument. Keep the operating instructions in a place that is accessible to all users at all times. Please assist us to improve these operating instructions, where necessary. We are always grateful for your suggestions.

Should any difficulties arise during start-up, you are asked not to carry out any unauthorized manipulations on the instrument as this could affect your warranty rights! Please contact the nearest Chemelex subsidiary or the head office. If any servicing is required, the instrument must be returned to the head office.

1.1 Certification

Chemelex certifies that this product meet its published specifications at the time of shipment from the Factory.

1.2 Warranty

This Chemelex product is warranted against defects in material and workmanship for a period of 12 months from the date

of installation or 30 months maximum from the date of shipment, whichever occurs first. During the warranty period, Chemelex will, at its option, either repair or replace products that prove to be defective.

For warranty service or repair, this product must be returned to a service facility designated by Chemelex. The Buyer shall prepay shipping charges to Chemelex and Chemelex shall pay shipping charges to return the product to the Buyer. However, the Buyer shall pay all shipping charges, duties, and taxes for products returned to Chemelex from another country.

Chemelex warrants that the software and firmware designated by Chemelex for use with a product will execute its programming instructions properly when installed on that product. Chemelex does not warrant that the operation of the hardware, or software, or firmware will be uninterrupted or error-free.

1.3 Limitation of warranty

The foregoing warranty shall not apply to defects resulting from improper or inadequate maintenance by the Buyer, Buyer-supplied software or interfacing, unauthorized modification or misuse, operation outside of the specifications for the product, or improper installation.

NO OTHER WARRANTY IS EXPRESSED OR IMPLIED. CHEMELEX DISCLAIMS THE IMPLIED WARRANTIES OF MERCHANTABILITY AND FITNESS FOR A PARTICULAR PURPOSE.

1.4 Exclusive remedies

THE REMEDIES PROVIDED HEREIN ARE THE BUYER'S SOLE AND EXCLUSIVE REMEDIES. CHEMELEX SHALL NOT BE LIABLE FOR ANY DIRECT, INDIRECT, SPECIAL, INCIDENTAL, OR CONSEQUENTIAL DAMAGES, WHETHER BASED ON CONTRACT, TORT, OR ANY OTHER LEGAL THEORY.

1.5 Statement of compliance

This equipment has been tested and found to comply with the low voltage directive 2006/95/EC and the electromagnetic compatibility directive 2004/108/EC. These limits are defined to provide reasonable protection against harmful interference in a residential installation (technical data mentions industrial application). This equipment generates uses and can radiate radio frequency energy and, if not installed and used in accordance with the instructions, may cause harmful interference to radio communications. However, there is no guarantee that interference will not occur in a particular installation. If this equipment does cause harmful interference to radio or television reception, which can be determined by turning the equipment off and on, the user is encouraged to try to correct the interference by one or more of the following measures:

- Reorientate or relocate the receiving antenna.
- Increase the separation between the equipment and receiver.
- Connect the equipment into an outlet on a circuit different from that to which the receiver is connected.
- Consult the dealer or an experienced radio/TV technician for help.

1.6 Area of use

Raychem NGC-40-SLIM limiters are used for temperature limiting of electrical heaters in industrial and potentially explosive atmospheres. The NGC-40-SLIM is a safety temperature limiter. NGC-40-SLIM units are approved for use in non-hazardous areas. Where needed the temperature sensor of the unit can be placed in Zone 1, Zone 2, Zone 21 and Zone 22 when the sensor is hazardous area approved.

1.7 Safety instructions

During operation, do not leave this Instruction Manual or other objects inside the enclosure. Use the limiter only for its intended purpose and operate it only in clean, undamaged condition. Do not make any modifications to the temperature controller and limiter that are not expressly mentioned in this installation manual.



Whenever work is done on the temperature limiter, be sure to observe the national safety and accident prevention regulations and the safety instructions given in this Instruction Manual.

1.8 Conformity with standards

NGC-40-SLIM units meet the requirements of the following functional safety standards and are developed, manufactured and tested in accordance with state-of-the-art engineering practice.

Title	Comment	Standard	Explanation
Electro Magnetic Compatibility	Complies to applicable EU directives	EN-61326:2002	Interference emission: Class B, immunity to interference: to Industrial requirements
New Approach Directives		Harmonized Standards	
Electrical Safety	Low Voltage Directive (LV)	Test voltages according to EN 60730-1 table 13.2	EN 60730-1 Automatic electrical controls for household and similar use – Part 1: General requirements
	Low Voltage Directive (LV)	EN61010-1:2004	Safety requirements for electrical equipment for measurement, control and laboratory use – Part 1: general requirements
2004/108/EC	Electromagnetic compatibility (EMC)	EN61000-6-3:2006 EN61000-6-2:2005 EN55011:2007 EN61010-1:2004	
Vibration		IEC 60068-2-6 Edition 7.0 2007-12	Frequency 10-55 Hz,@ 0.35MM(0 – Pk),Sweep Rate: 10 ct/Min, Total: 10 Sweep Cycles/Axis, Duration: 49Min/Axis
Shock		IEC 60068-2-27 Edition 4 2008-02	Acceleration 50 g, half sine-wave, 11 msec duration 3 pulses in 6 directions

Table 1: Standards overview

1.9 Approvals and certifications

IECEX Markings: IECEX ETL17.0062X
Ex ec nC IIC T4 Gc

ATEX Markings: ITS17ATEX402833X
Ⓔ II 3 G Ex ec nC IIC T4 Gc



(Russia, Kazakhstan, Belarus)
For other countries contact your local Chemelex representative.

Special conditions of use:

- The overall equipment is evaluated to type of protection “ec”. Sealed devices in the form of relays are additionally present in module NGC-40-SLIM and comply with requirements for the type of protection nC.
- For full connection details see these installation instructions. The equipment shall only be used in an area of not more than pollution degree 2, as defined in IEC/EN 60664-1.
- The equipment shall be installed in an enclosure that provides a minimum ingress protection of IP54 in accordance with IEC/EN 60079-0.
- Transient protection shall be provided that is set at a level not exceeding 140% of the peak rated voltage value at the supply terminals to the equipment.

2 TECHNICAL DATA

2.1 Product Description

The NGC-40-SLIM module is used as safety temperature limiter within the NGC-40 control and monitoring system. The module has one output for the contactor, one alarm output and one digital input. The alarm output can be used to control an external annunciator. The digital input can be used for resetting the limiter remotely. The module has 3 temperature inputs which can be used all in case of a three phase heat-tracing system. The limiter is equipped as smart limiter where the current measurements are done in the associated controller. The front panel of the SLIM module has LED indicators for various status conditions.

The front panel also provides “Set Config”, “Trip Reset” and “Alarm Reset” buttons.

2.1.1 Tools Required

- Small flat-blade screwdriver

2.1.2 Additional Materials required

- Power supply 24 Vdc @100 mA per NGC-40-SLIM, CE Certified
- Custom built CAN cables with RJ-45 connections
- CAN Bus Termination Block (part nr.: 10392-043)

2.1.3 Kit Contents

Item	Quantity	Description
NGC-40-SLIM	1	Safety Temperature Limiter
INSTALL-171	1	NGC-40-SLIM installation instructions

2.1.4 General information

- Supply voltage 24 Vdc \pm 10%
- Internal power consumption < 2.4 W per NGC-40-SLIM module
- Ambient operating temperature 0°C to 65°C (32°F to 149°F)
- Ambient storage temperature -55°C to 75°C (-67°F to 167°F)
- Environment PD2, CAT III
- Max. Altitude 2,000 m (6,562 ft)
- Humidity 5 – 90% non condensing
- Mounting Din Rail – 35 mm

2.1.5 Measuring range

Temperature range limiter from +70°C to +500°C (158°F to 932°F)

2.1.6 Electromagnetic Compatibility

2.1.6.1 Emissions

EN 61000-6-3, Emission standard for residential, commercial and light industrial environments

2.1.6.2 Immunity

EN 61000-6-2, Immunity standard for industrial environments

2.1.7 Temperature Sensors

Type: 100 Ω platinum RTD, 3-wire, $\alpha = 0.00385$ ohms/ohm/ $^{\circ}$ C. Can be extended with a 3-conductor shielded cable of 20 Ω maximum per conductor

Quantity: 3 per NGC-40-SLIM module

2.1.8 Alarm Relay

Dry contact relay (voltage free). Relay contact rated 250 V / 3 A, 50/60 Hz (CE). Alarm relay is programmable. NO or NC can be configured.

2.1.9 Contactor Output Relay.

Relay contact rated 250 V / 3 A, 50/60 Hz (CE)

2.1.10 Digital Input

Digital input is used for resetting the safety temperature limiter remotely.

The Digital Input will be for connection to external dry (voltage free) contactor or DC voltage. The input would be 5 – 24 VDC/1 mA max with 100 ohms of loop resistance and configured as active low.

2.1.11 CAN Networking Port

Type: 2-wire isolated CAN-based peer to peer network. Isolated to 24 Vdc – verified by 500 Vrms dielectric withstand test

- Connection: Two 8-pin RJ-45 connectors (both may be used for Input or Output connections)
- Protocol: Proprietary NGC-40
- Topology: Daisy chain, terminate with TTC, CAN termination block (see Figure 8).
- Cable length: 10 m (33 ft) maximum
- Quantity: Up to 80 modules per network segment
- Address Unique, factory assigned

2.1.12 Connection terminals

Wiring terminals Cage clamp, 0.5 to 2.5 mm² (24 to 12 AWG)

Housing: Size 45.1 mm (1.78 in) wide x 87 mm (3.43 in)

high x 106.4 mm (4.2 in) deep outputs

- Form-A 250 Vac/3 A dry contact (voltage-free) alarm relay, programmable for steady or flashing on alarm.
- Form-A 250 Vac/3 A contactor coil drive relay. This output is used in conjunction with the terminals to provide switched LINE voltage to an external contactor coil.

2.1.13 NGC-40 Safety Limiter

Product name: NGC-40-SLIM

Part number: 1244-010700

2.1.14 NGC-40-SLIM accessories and associated components

Product name	Part number
NGC-40-HTC	10730-003
NGC-40-HTC3	10730-004
NGC-40-IO	10730-001
NGC-40-BRIDGE	10730-002
NGC-40-PTM	10730-005
MONI-RMC-PS24	972049-000

2.1.15 Dimensions

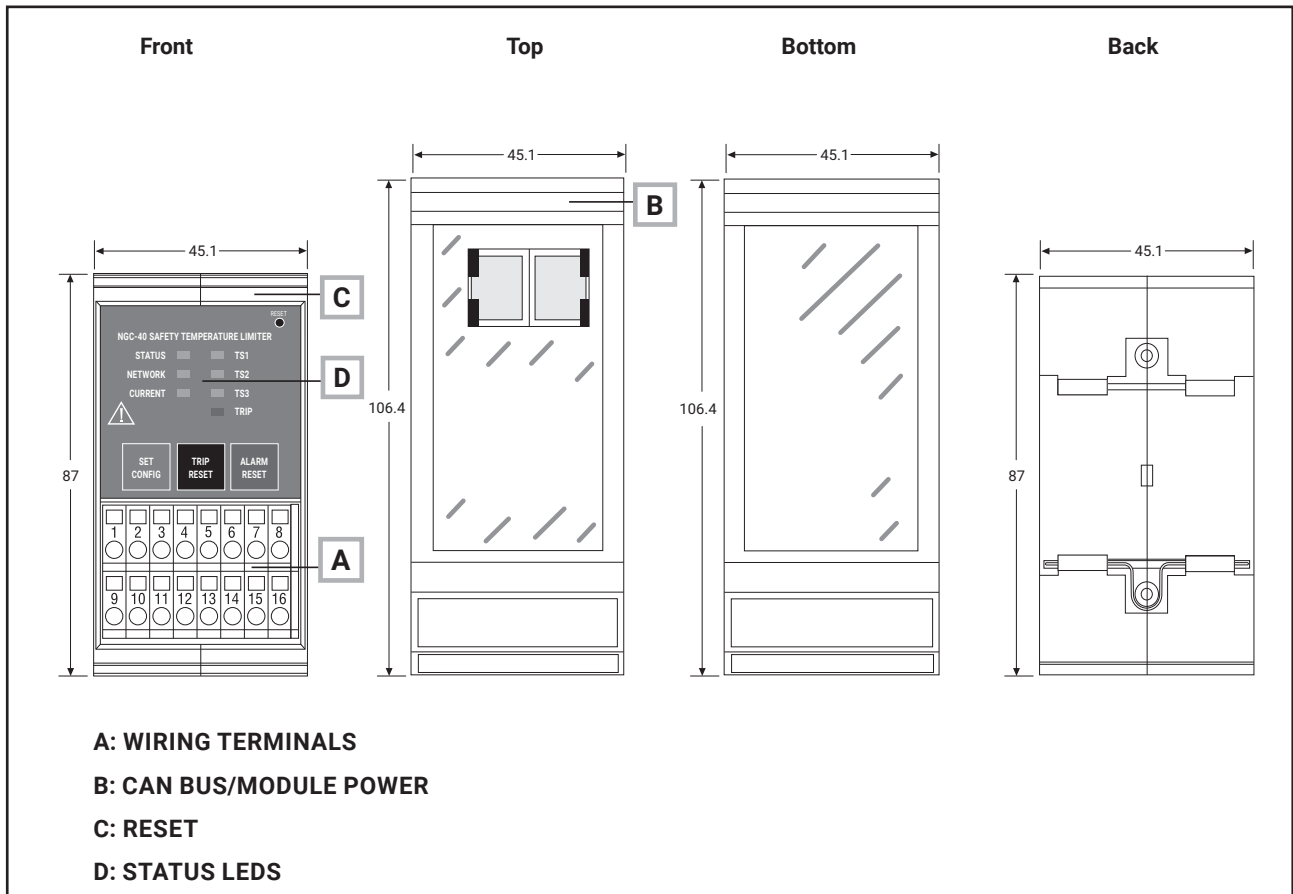

Figure 1: Dimensions NGC-40-SLIM module

A: WIRING TERMINALS:

Term	Limiter Module
1	Output relay
2	Output relay
3	Alarm relay
4	Alarm relay
5	--
6	TS1 common
7	TS1 sense
8	TS1 source
9	TS2 common
10	TS2 sense
11	TS2 source
12	TS3 common
13	TS3 sense
14	TS3 source
15	Digital In +
16	Digital In -

Table 2: Wiring terminals

State	LED						
	Status	Network	Current	TS 1	TS 2	TS 3	Trip
OFF	No Power		No current	No alarm	No alarm	No alarm	Not Tripped
RED	Device-reset alarm is active						Tripped
GRN	Normal operation, no internal faults	Flicker on receipt of CAN packet	Current				
YEL	In Boot Loader mode	Flicker on transmission of CAN packet					
Flash RED	Internal Fault: • Lost calibration			TS 1 sensor failure alarm	TS 2 sensor failure alarm	TS 3 sensor failure alarm	
Flash GRN							
Flash YEL	Tripper and non-latching						
Flash RED/ GRN	Factory unlock / un-calibrated						
Flash RED/ YEL							
Flash YEL/ GRN							

Table 3: LED status of NGC-40-SLIM module

Note: For the SLIM module, when ALL LEDs are flashing red, the unit has lost factory calibration, cannot be communicated with, and must be returned to the factory for repair/replacement.

2.2 Mounting and wiring NGC-40-SLIM module

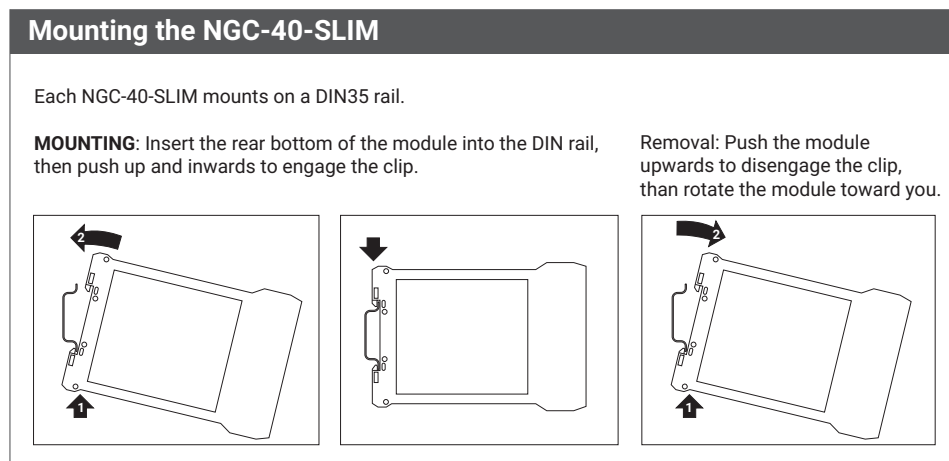

Figure 2: Mounting NGC-40-SLIM module onto DIN rail

Power Supply/CAN

The power supply/CAN connector is an RJ-45 connector

Cable from another module or power supply

CAN termination here if last one in chain

The CAN termination device must be installed in the unused port of the last module.

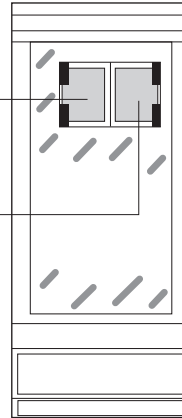
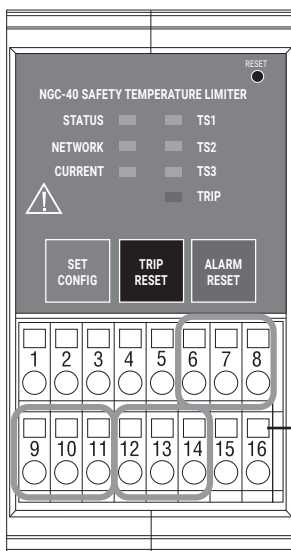

Figure 3: Power via CAN cable connector

RTD Terminals



	Sensor 1	Sensor 2	Sensor 3
Common (white)	6	9	12
Sense (red)	7	10	13
Source (red)	8	11	14

The RTD field wires must be terminated on a panel-mounted terminal block. The RTD cable shield from the field terminal block to the HTC module should be terminated at the earth ground bar located near the module.

Figure 4: Temperature sensor connections to terminals

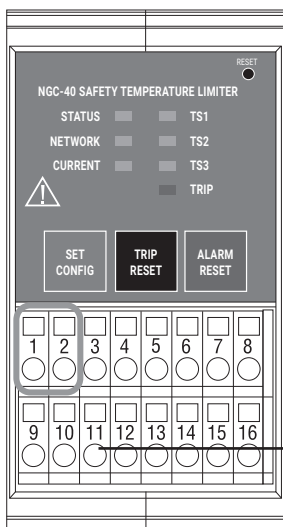

Contacter Relay

Contacter relay uses terminal 1 and 2, Form A, NO dry contact, rated at 250 Vac max, 3 A.

Contact is energized & closed during normal conditions and will open upon an trip or power failure condition.

Figure 5: Contacter terminals

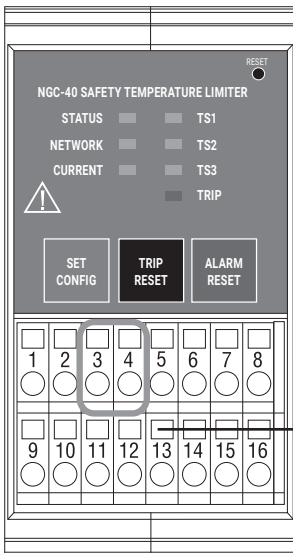

Alarm via Digital Output
 Alarm relay using terminal 3 and 4,
 Form A, NO dry contract, rated at 250 V max, 3 A.
 Contact is energized & closed during normal conditions
 and will open upon an alarm condition.

Figure 6: Alarm terminals

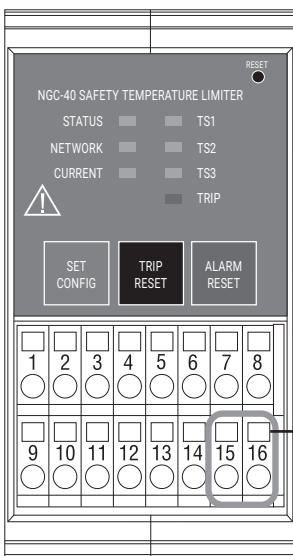

Trip reset (Digital Input)
 Terminal 15 and 16.
 100 Ω max loop resistance or 5-24 Vdc @ 1 mA maximum

Figure 7: Trip reset digital input

NGC-40 CAN Bus Connections for up to 10 Modules

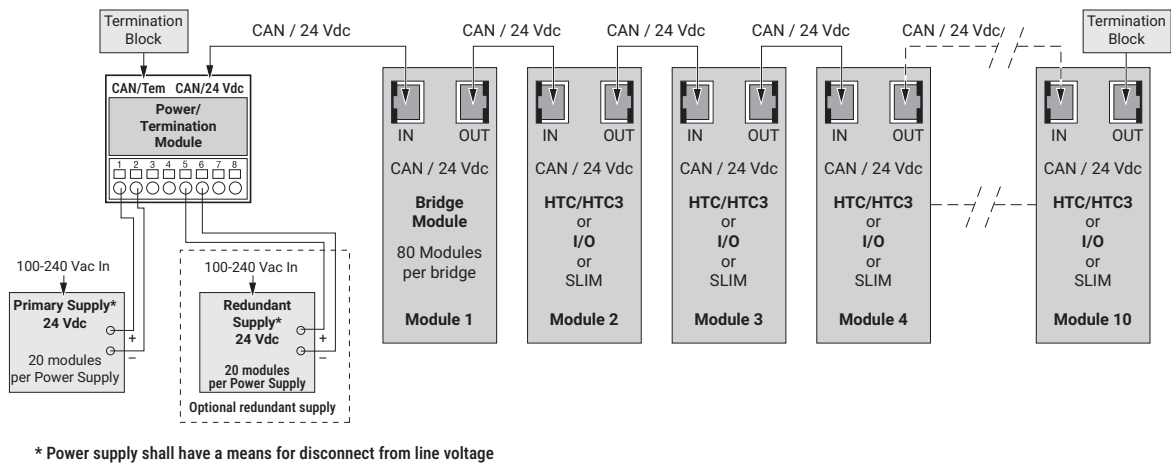

Figure 8: CAN network connections for up to 10 modules

NGC-40 CAN Bus Connections for up to 20 Modules

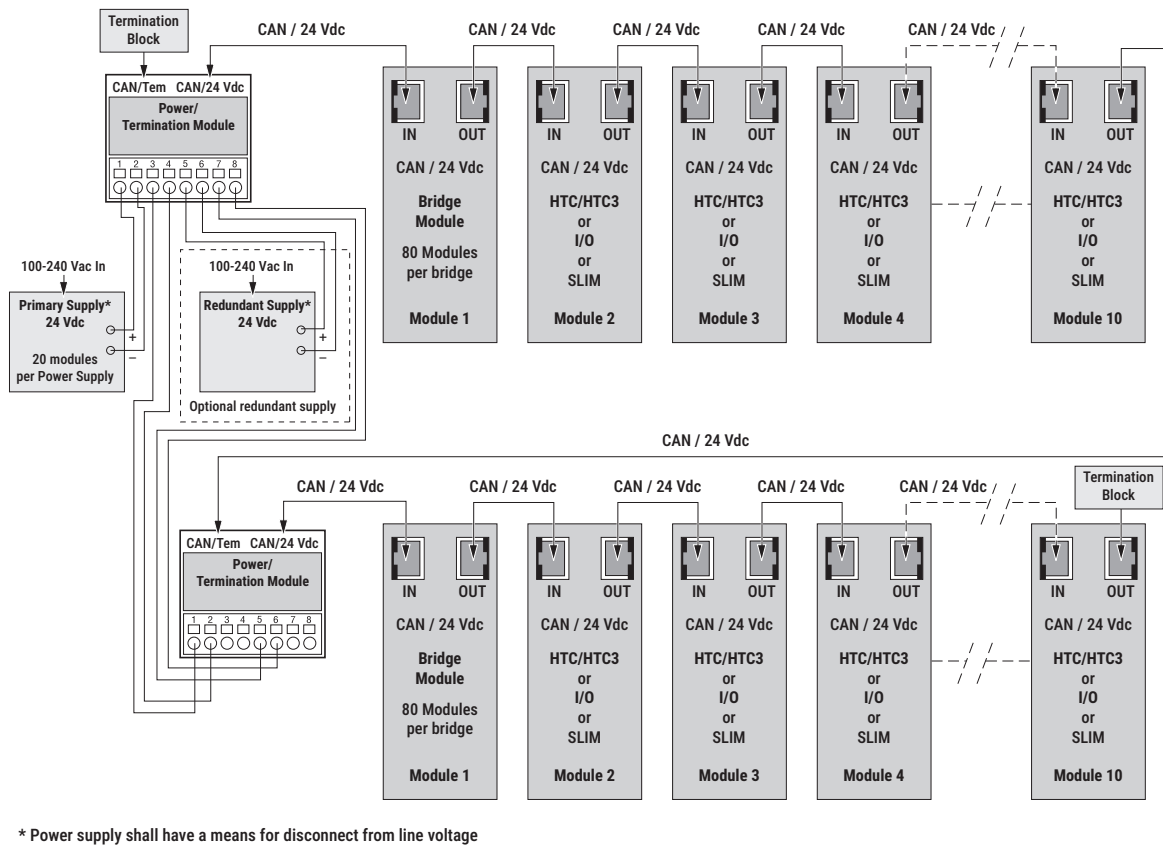
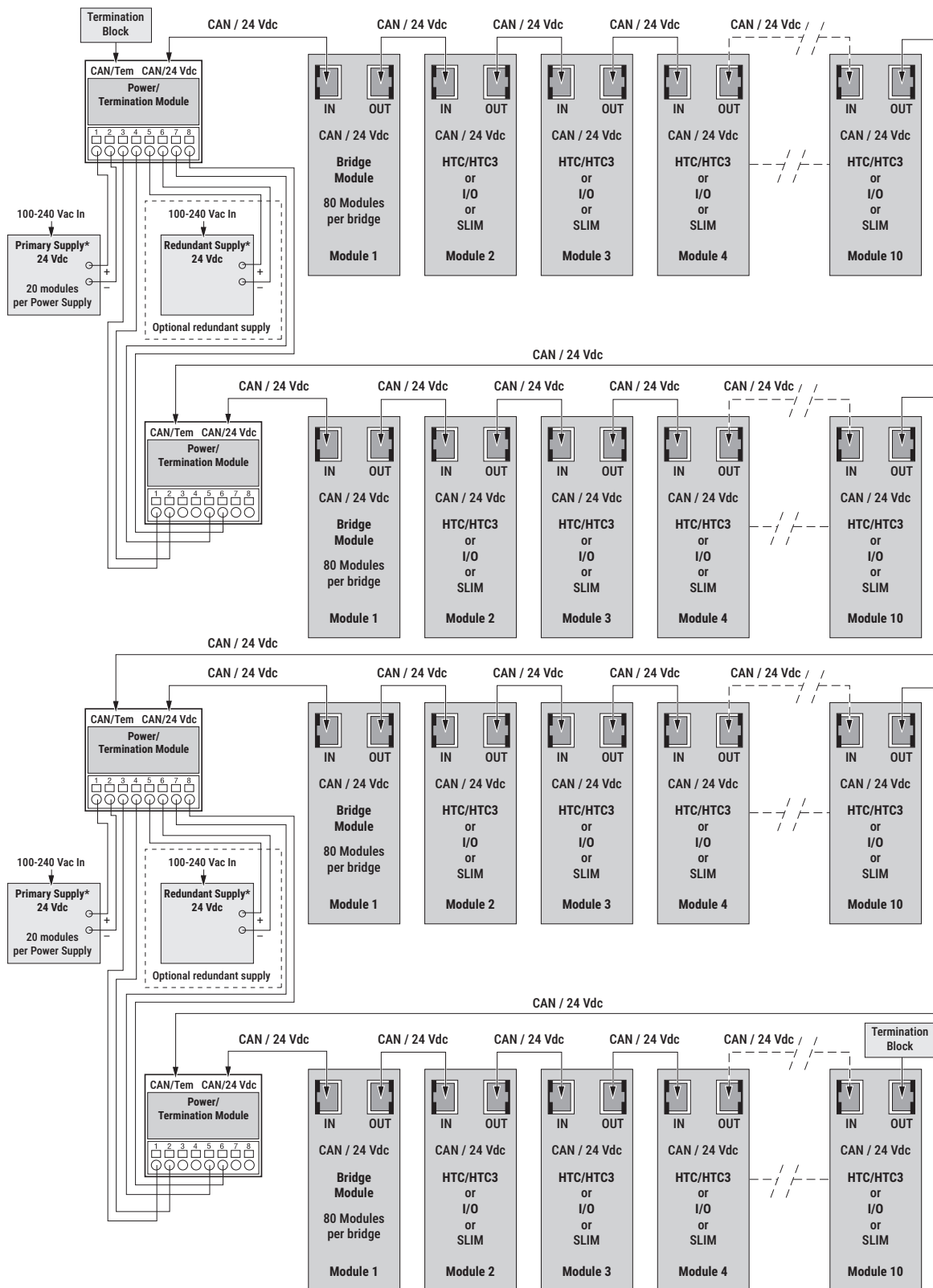

Figure 9: CAN network connections for up to 20 modules

NGC-40 CAN Bus Connections for up to 40 Modules



* Power supply shall have a means for disconnect from line voltage

Figure 10: CAN network connections for up to 40 modules

The location of the SLIM module is free to choose after the bridge module. Via configuration tools the limiter will be linked to the associated controller.

3 SAFETY INSTRUCTIONS FOR NGC-40-SLIM

3.1 Area of use

Safety temperature limiters are required in all areas where thermal processes need to be prevented from overheating, and where the system must be set to a safe operating condition in the event of a fault.

Typical examples of such installations could be surface heating installations in Hazardous area Zone 1

3.2 Safety function of temperature limiter in NGC-40-SLIM

The safety function will invoke, when the permissible temperature limit is reached or in case a fault occurs (such as probe break, probe short-circuit, component failure, or supply failure) even when the process conditions are within the permissible temperature range. In all these cases the equipment is immediately switched off. If the fault is no longer present, than the safety temperature function must be manually reset before the unit goes back to normal operation. NGC-40-SLIM units can be reset by means of a Trip Reset push button, an external hardwired signal or via dedicated software. The output of the unit will only be enabled when all conditions are safe; meaning that the temperature measured by the limiter RTD has dropped below the limiter set point and when there are no other faults being detected. In other words, the unit will only reset after the normal operating conditions have returned.

3.3 Temperature limiter (schematic)

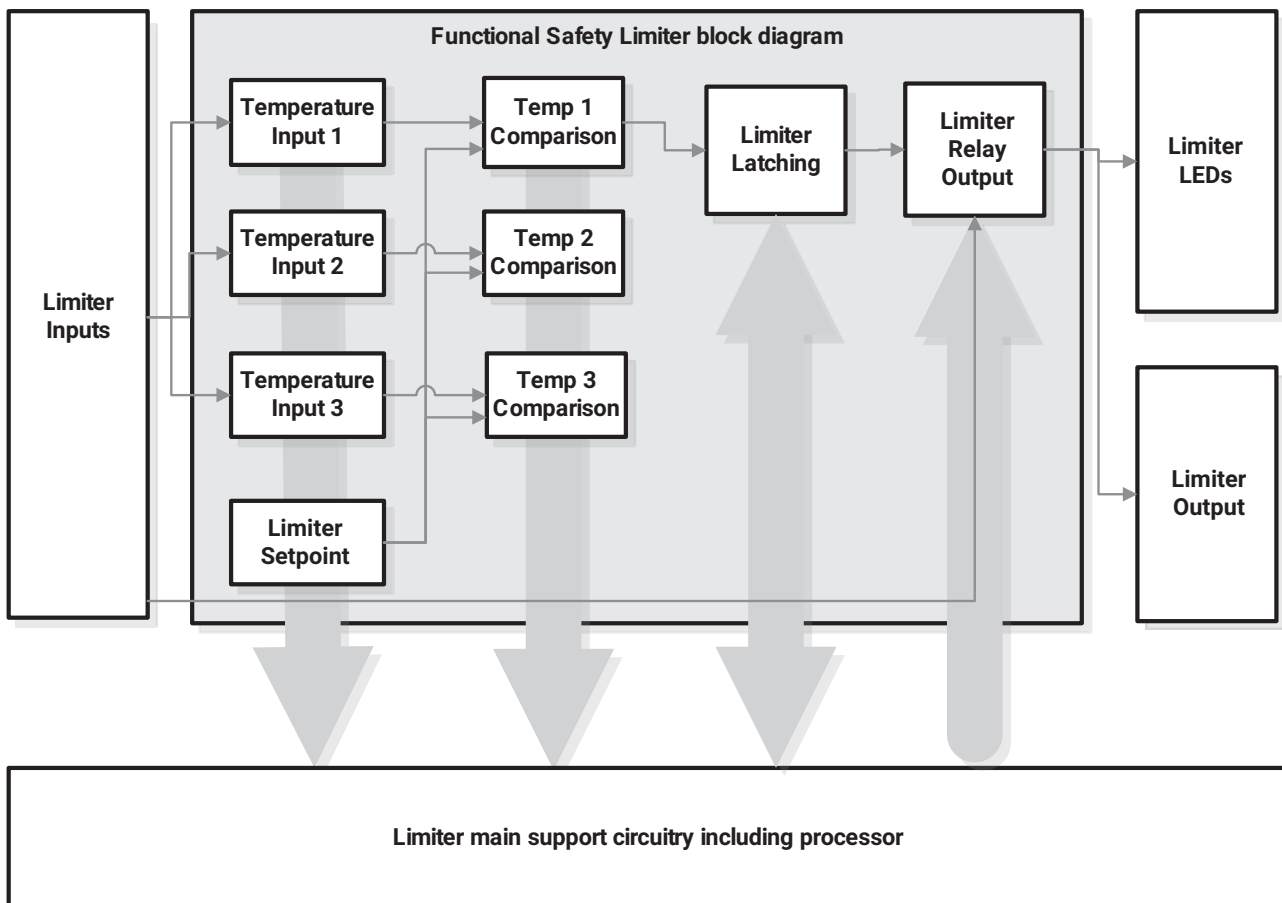

Figure 11: Safety Temperature Limiter block diagram

3.4 Reset Safety Temperature Limiter

The safety temperature limiter is designed such that after the temperature limiter has tripped the device needs to be reset manually. Resetting is possible only after the normal, safe operating conditions have returned. In order to RESET the limiter after it has tripped, the user needs to press the Trip Reset pushbutton as is shown in Figure 12. Alternatively the safety temperature limiter can be reset via Raychem Supervisor, Raychem TOUCH 1500. Refer to the operating manual of the specific units for more detailed instructions on how to use these devices.

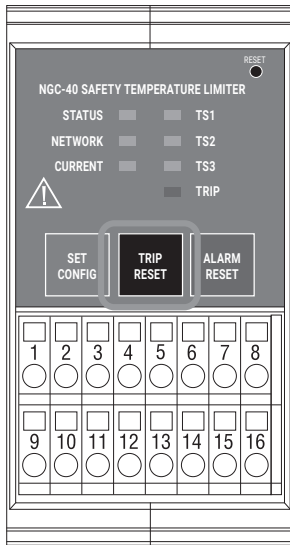

Figure 12: “Trip Reset” button

3.5 Temperature setting secured and locked to prevent manipulation

The lock out temperature (set point) of the safety temperature limiter must be set in such a way that maximum T-class temperature cannot be exceeded. The surface temperature of the heat-tracing cables is limited to the temperature applicable in this T class -5 K for temperatures below or equal to 200°C or -10 K for temperatures greater than 200°C. Refer to section 3.7 below for the procedure to change the safety limiter set point. The safety temperature limiter operates totally independent of the temperature control system and has its own temperature inputs (RTD Limiter). In case of a defect to any part of the NGC-40-SLIM unit the device shall be de-energized before replacing the defective equipment.

3.6 Changing limiter set point

Changing the set point of the limiter requires the combination of the SET CONFIG button on the SLIM and an external user interface.

3.7 Procedure to write new temperature set point to limiter

In order to write a new set point to the safety temperature limiter a safety procedure needs to be followed. Changing the set point of the temperature limiter requires the combination of the limiter “Set Config” button and a programming device. For a programming device one can use Supervisor software or the TOUCH 1500.

The procedure to change the limiter set point is the same for all user interfaces. The configuration software will write the new set point to the input buffer of the NGC-40-SLIM controller only when the “Set Config” button is pressed. The limiter set point button needs to be activated within a certain time after the buffer has been loaded with the new set point.

If the button has not been pressed before the programming window is elapsed, the buffer will be emptied and the old value remains unchanged. Once the new set point has been written the new, or in case the write procedure was not successful, the old set point will be read back by the programming device as confirmation to the user. After changing the limiter set point the user shall verify whether the set point has been updated correctly. Each time after the limiter set point has been altered a functional test as per paragraph 3.9 should be performed.

3.8 Test in the event of a fault

In the event of a system fault, the limiter switches off the load. This condition is indicated by the LED “TRIP” which will light up. The fault is signalled simultaneously by the alarm relay which changes state. Press the “TRIP RESET” button (at least 2 sec) until the limiter tripped LED is off. If the safety circuit remains open, the system and the RTD circuit have to be checked.

Press the “TRIP RESET” button again. If the limiter remains inhibited after pressing the reset button the unit should be replaced.

3.9 Safety related system characteristics

The failure types of; sensor break, sensor short, sensor misconnected and random hardware failure are permanently monitored.

IMPORTANT NOTICE

In case a failure of the safety system is detected either during operation or during routine maintenance when executing a function test the unit should be switched off and taken out of service. Defects in the safety system cannot be repaired in the field. Defective units are to be replaced and returned to the manufacturer for investigation. Please contact your nearest Chemelex representative for more instructions. A list of worldwide representations can be found on the last page of this document or on chemelex.com.

België / Belgique

Tel +32 16 21 35 02
Fax +32 16 21 36 04
SalesBELUX@chemelex.com

Bulgaria

Tel +359 2 973 33 73
SalesEE@chemelex.com

Česká Republika

Tel +420 606 069 618 (Comm)
+420 602 232 969 (Ind)
infoCZ@chemelex.com

Danmark

Tel +45 70 11 04 00
SalesDK@chemelex.com

Deutschland

Tel 0800 181 82 05
SalesDE@chemelex.com

España

Tel +34 911 59 30 60
Fax +34 900 98 32 64
SalesES@chemelex.com

France

Tél 0800 90 60 45
SalesFR@chemelex.com

Hrvatska

Tel +385 51 225 073 (Comm)
+385 1 605 01 88 (Ind)
SalesEE@chemelex.com

Italia

Tel +39 02 577 61 51
Fax +39 02 577 61 55/28
SalesIT@chemelex.com

Lietuva/Latvija/Eesti

Tel +370 698 411 56
SalesEE@chemelex.com

Magyarország

Tel +36 1 253 76 17
SalesHU@chemelex.com

Nederland

Tel 0800 022 49 78
SalesNL@chemelex.com

Norge

Tel +47 66 81 79 90
SalesNO@chemelex.com

Österreich

Tel 0800 29 74 10
SalesAT@chemelex.com

Polska

Tel +48 22 331 29 50
Fax +48 22 331 29 51
SalesPL@chemelex.com

Қазақстан

Tel +7 7112 31 67 03170
SalesKZ@chemelex.com

Serbia and Montenegro

Tel +386 41 665 634 (Comm)
+381 230 439 519 (Ind)
SalesEE@chemelex.com

Schweiz / Suisse

Tel +41 (41) 766 30 80
Fax +41 (41) 766 30 81
infoCH@chemelex.com

Suomi

Puh 0800 11 67 99
SalesFI@chemelex.com

Sverige

Tel +46 31 335 58 00
SalesSE@chemelex.com

Türkiye

Tel +90 545 284 09 05
SalesEE@chemelex.com

UK/Ireland

Tel 0800 969 013
SalesUK@chemelex.com

chemelex
excellence is everything

Raychem Tracer Pyrotenax