

TT7000-HUV

TraceTek Sensing Cable for Strong Mineral Acids Installation Instructions

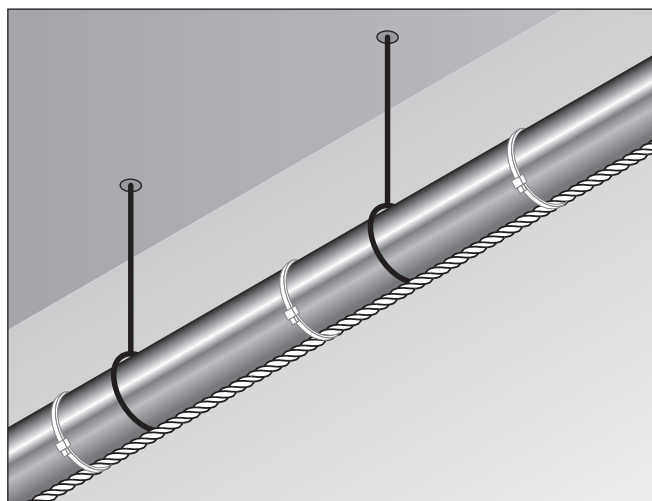

TOOLS REQUIRED

Wire cutters	Used to cut off extra tie wrap ends
Raychem TT-PTB-1000 (part # 486437-000)	Portable Test Box, battery powered instrument specifically designed for testing and trouble shooting TraceTek systems
Ohmmeter (>20 M ohm)	Can be used as an alternative and supplement to the PTB 1000
Raychem TT-MAPPING CAP-MC (part # P000000871)	Used to simulate leaks at connector points during commissioning and mapping process
Extra Raychem TT-MLC-MC-BLK (part # 133332-000)	Leader cable. Used with the ohmmeter to make easier connections to the sensor cable for resistance measurements
Extra Raychem TT-MET-MC (part # 571293-000)	End termination. Used during installation or trouble shooting to temporarily isolate a sub-section of sensor cable for resistance measurements

ADDITIONAL MATERIALS REQUIRED

Tie wraps	Supplied by installer and sized to go around the pipe and sensor cable. Base quantity on one tie wrap per foot (0.3 m) for horizontal run with extra wraps at fittings.
Rags and appropriate cleaner	Use to wipe and clean bottom and side surfaces of pipe prior to cable installation.

DESCRIPTION

These instructions explain the proper procedures for installing and testing Raychem TraceTek TT7000-HUV sensing cables. TT7000-HUV sensing cables are primarily intended for use on overhead piping, vertical pipe, valves and manifolds and other fittings where concentrated sulfuric or nitric acid could leak. TT7000-HUV sensing cables can also be used on floors, in drip pans, in sumps, trenches and underground in slotted conduit. TT7000-HUV sensing cables ignore water but will detect and locate strong mineral acid spills and leaks if they are of sufficient concentration. (See the data sheet for specific performance characteristics.).

IMPORTANT NOTES

When used to monitor suspended or rack mounted pipe, TT7000-HUV sensing cables must be attached to the pipe system at the lowest point where any acid leak is most likely to drip from the pipe system. Usually this will be the 6 o'clock position on horizontal piping but other mounting locations and techniques may be necessary if site conditions are unusual. In particular, special consideration should be given to pipe supports, couplings, "T's", valves and other fittings. It is the responsibility of the installer to position the cable such that any leak will drip onto the cable.

TT7000-HUV sensing cables are designed for demanding indoor or outdoor environments. The TT7000-HUV is a small diameter, flexible cable consisting of four wires wrapped around a central core. Two of the wires are acid sensitive electrodes that are jacketed with a protective coating material that provides a water resistant barrier. An outer layer rope-braid of synthetic fiber provides further protection from UV radiation. TT7000-HUV cable can be exposed to sunlight, rain, snow, fog, condensation, dust, blowing dirt and other contaminants without causing a false alarm. When acid contacts the TT7000-HUV cable, the acid is absorbed by the outer rope layer, then dissolves the protective coating on the acid sensitive cable electrodes — resulting in the leak detection signal.

The sensor cable cannot stop a leak. In some installations, the materials or structures beneath the pipe system may be so critical or valuable, that a drip tray system should be considered in addition to the sensor.

OPTIONAL MATERIALS

Raychem TT-MBC-MC-TW (part # P000001206)	Branch connector designed for rugged outdoor applications used to connect and branch "T" lines
Raychem TT-MJC-XX-MC-BLK	Jumper cable is available in various pre-cut and terminated lengths.
TT7000-HUV-CK-MC-M/F (part # P000001187)	Connector kit used during field connection of TT7000-HUV bulk cable.

⚠️ GENERAL NOTES: DO'S AND DON'TS:

DO:

- Store the cable in its original container in a clean, dry area until ready to install.
- Clean the pipe surface where the cable will be installed.
- Schedule the sensor cable installation as late as possible in the construction schedule to avoid risk of damage or contamination by other contractors or construction tasks.
- Remove cable from the pipe if any thread cutting, welding, or similar pipe fitting work will be performed.

DON'T:

- Drag the cable through water, paint, solvents, oil or other contaminants.
- Install damaged or contaminated sensing cable.
- Exceed the maximum pulling force of 100 kg (220 lb).
- Use the cable as a rope for lifting or securing any object.
- Allow tools or heavy objects to fall on cable.
- Exceed 3300 ft (1000 m) of individual sensor cable circuit length when using a SIM alarm module.
- Test the cable with acid.

Installation

1

Clean and prepare the pipe or area where the cable will be installed.

1. Verify that major construction is complete.
 - Clean the bottom and sides of the pipe where the cable will be installed to remove any residual acid waste or contaminant
 - If the cable will be placed in drip trays, make sure to wipe the surface of the drip tray and remove any liquids or debris.
 - For sumps, containment trenches, and subfloor applications, install TraceTek hold-down clips. For TraceTek TT7000-HUV series sensing cables, use 1/2-inch (13 mm) hold-down clips (TT-HDC-1/2-NA-50).
 - Clean the floor surface where hold-down clips will be placed so adhesive can work properly.
 - Position hold-down clips so the sensing cable will provide the desired leak detection coverage. To best secure the cable, alternate the direction of the hold-down clips, and install them at intervals of no greater than 6 feet (2 m) and at every change in direction (at sides of trench, for example).

Important: Let the adhesive dry per manufacturer's recommendation before proceeding with sensing cable installation.

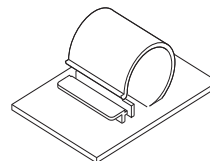
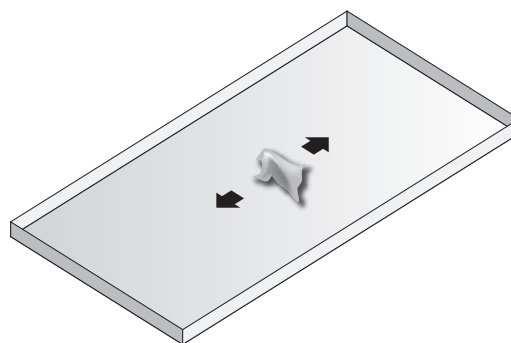
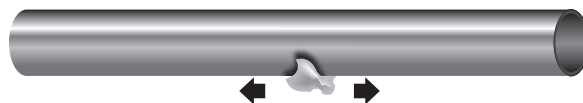

TT-HDC-1/2-NA-50

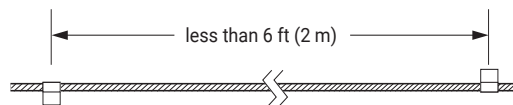

2

Check each length of sensing cable before installation.

To ensure that each length of sensing cable is intact and free of contamination, follow the Sensing Cable Test Procedure. Do not use damaged or contaminated sensing cable.

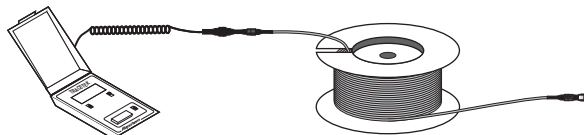

3

Observe proper precautions when handling sensing cables.

Observe the do's and don'ts under "General Notes" on page 1 of these instructions; take care to avoid damaging or contaminating sensing cable.



Connect, orient, install, and test each length of sensing cable in sequence

1. **Connect** a Modular End Termination (TT-MET-MC) to the first sensing-cable length to be installed.
2. **Orient** sensing cable so the connector used with the end termination will be the furthest away from connection to the TraceTek alarm module. Work out from the alarm module connection. For sensing cable on reels (lengths over 10 feet (3 m)), put the reel on an axle and pull the cable out.
3. **Install** sensing cable in accordance with the leak detection layout plan.
 - A. For pipeline applications:
 - Position the cable along the bottom of the pipe and use tie wraps to secure the cable at the 6 o'clock position. Maintain cable position within 1/4 inch (6 mm) of 6 o'clock position.
 - Tie wraps should be long enough to go around the pipe and the sensor cable.
 - Use one tie wrap every 12 in to 18 in (300 to 450 mm) along the pipe with extra tie wraps at fittings or bends as needed.

Important: It is the installer's responsibility to position the sensor cable correctly. The cable must trace the lowest point of the pipe or fittings such that any acid leaking from the pipe or fittings will drip onto the cable surface as it drips off the bottom of the pipe or fitting. Do not install the cable on the top or side surface of a pipe. Do not spiral the cable on horizontal pipe.

Exception: If the cable is used to trace vertical pipe, the cable should be spiraled around the pipe and secured with tie-wraps.
 - B. For sumps, containment trenches, and subfloor applications:
 - Pull the cable alongside the installed hold-down clips; minimum bend radius is 2 in (50 mm). Leave 6 in (150 mm) of sensing cable on each end for the connector service loop.

Important: Verify that the adhesive securing the hold-down clips has dried; liquid adhesive must not contact the cable. Push sensing cable into the hold-down clips and position the sensing cable to lay flat on the surface to be monitored.
4. **Test** each length of sensing cable after installing it and before attaching it to cable already installed. Confirm that the sensing cable is clean and intact by following the Sensing Cable Test Procedure.
5. **Connect** the sensing cable to the cable string (lengths of sensing cable connected in series) previously installed; before making connection push heat-shrinkable tube onto sensing cable.

Note: If installing sensing cable in a double-wall tank or other inaccessible location, the heat-shrinkable tube must be shrunk down before installation; see step 5 for installation instructions.

For sumps, containment trenches, and subfloor applications:

 - Leave a service loop at each connector as shown.
 - Mark the connector position on the layout plan.
 - Install TraceTek mapping tag (TT-TAG).
 - Note: As an extra precaution on large installations, periodically test the entire cable string to confirm that all installed sensing cable is still clean and intact.
 - Unplug the end termination and connect it to the next length of sensing cable to be installed.
6. **Repeat** the installation sequence for each length of cable.

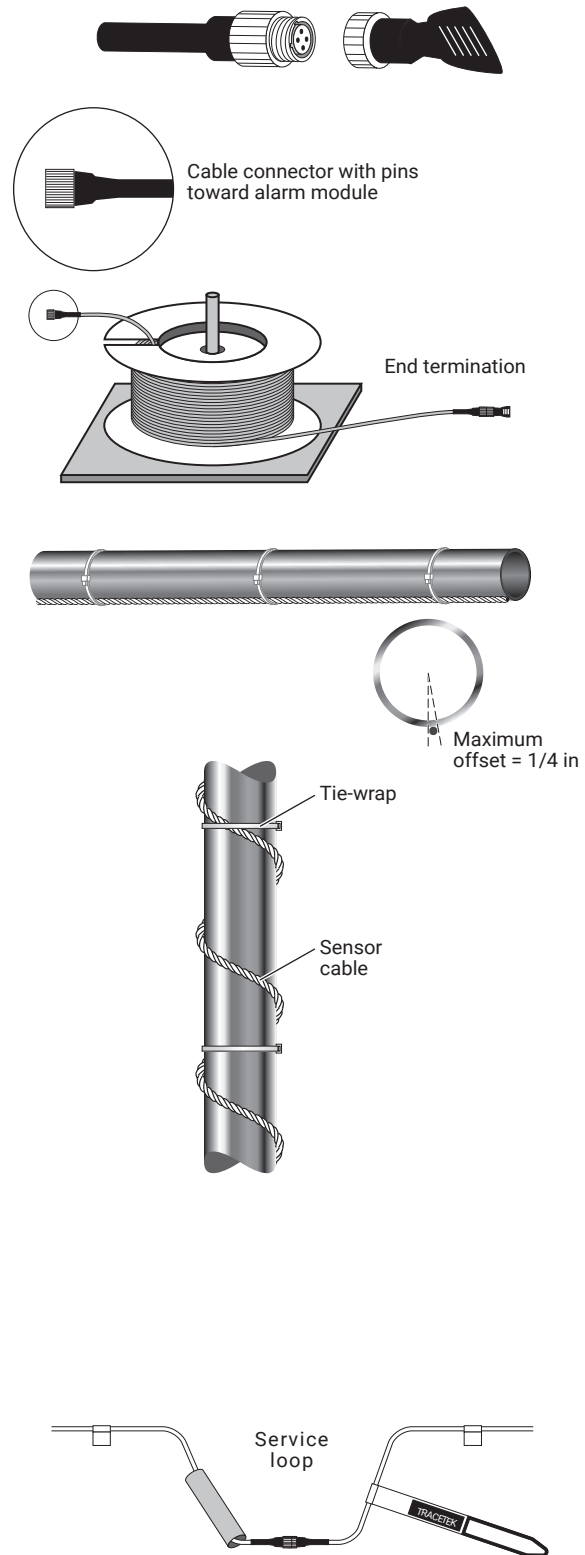

5

Complete the system

1. Install other TraceTek components (such as Modular Branching Connectors, Weighted Lengths, and Modular Jumper Cables) as called for in the system layout. Complete the sensing circuit.

Note: All components of the system have male or female metal connectors or both. The male connectors are oriented toward the instrument panel. As new sections of cable are added to the main leg or branch, each newly added section should end with an open female connector. The end of each branch or main leg is terminated with a male end termination.

2. Test the sensing circuit (or portions of it) to confirm that the sensing cable is clean and intact. Follow the Sensing Cable Test Procedure.
3. Install heat-shrinkable tubes over all mated male/female (pin/socket) connections
 - Move the heat-shrinkable tube along the sensing cable until it is centered over the mated connection.
 - Using a heat gun with a concentrator tip or TT-ULTRA-TORCH (PN 390067-000), shrink the tube over the connection. Begin in the center and shrink toward each end until tube fully conforms to the shape of the connection.
 - **Note:** If a heat-shrinkable tube must be removed (for example, for cable testing), refer to Oversleeve Removal Instructions (H54258).
4. Connect the sensing circuit to the TraceTek alarm module and activate the system as soon as is practical. Use the alarm module to monitor for events during the final stages of construction.

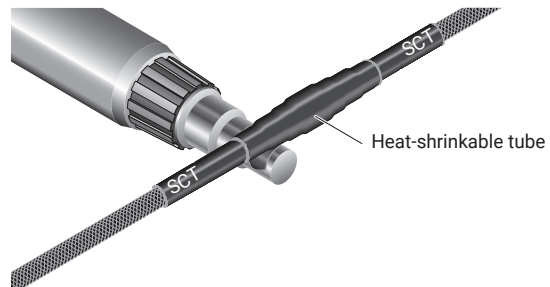
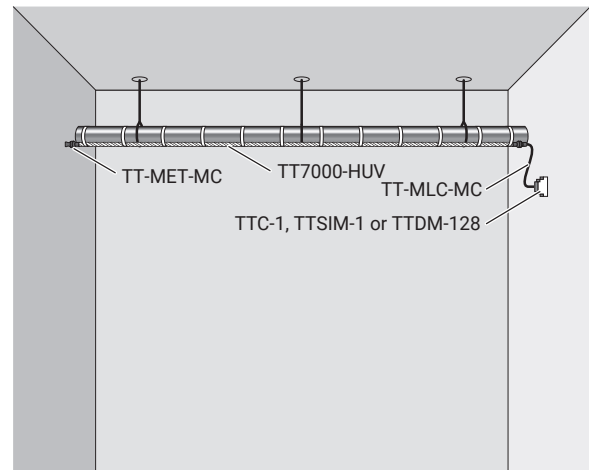

6

Take precautions if installation is incomplete at end of work day.

At the end of the work day:

- Ensure that there are no exposed connectors. Each sensing cable should be connected to a Modular Leader Cable (TT-MLC-MC), Modular End Termination (TT-MET-MC), and/or other sensing cables; check both ends of the cable.
- Test and record the condition of installed sensing cable following the Sensing Cable Test Procedure.
- If practical, connect the installed sensing cable to the TraceTek alarm module. Test the system and put it in operation following the alarm module installation instructions.

At the beginning of the next work day:

- Check that the installed sensing cable is clean and intact following the Sensing Cable Test Procedure. Compare the results with those obtained at the end of the previous work day. If necessary, investigate and correct problems before proceeding.

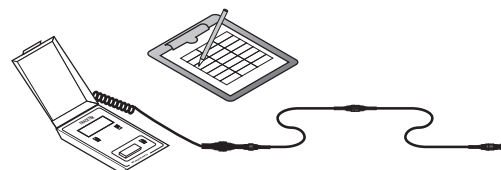

Sensing Cable Test Procedure

Method with Raychem TraceTek Portable Text Box (PTB)

1. Ensure the end termination is connected to the sensing cable. If checking several lengths of sensing cable in series (a cable string), ensure they are all connected.
2. Connect the PTB to the sensing cable(s) using its adapter, as illustrated.
3. **Verify that the sensing cable is intact;** follow the operating instructions printed inside the lid of the PTB itself. If a cable or connection is broken, the PTB illuminates its LED indicating "cable break," and displays a "1" in the leftmost position of its LCD display. If the cable string is intact, the PTB measures the system length.
 - **Note: Because the PTB is precalibrated for a cable resistance value of 4 ohms/ft, any length values displayed on the PTB need to be multiplied by a factor of 1.6 to properly correspond to TT7000-HUV cable.**
 - If the cable string is not intact, apply this test procedure to segments of the system to identify the open connection or damaged modular length.
 - **Note:** If a heat-shrink tube must be removed to access a connector, refer to Oversleeve Removal Instructions (H54258).
4. **Check the condition of the sensing cable(s),** again following the PTB operating instructions. If the sensing cables are clean and free of contamination, the current measured should be below 10 μA . If the reading exceeds 10 μA , use the PTB to locate the liquid or contamination and take appropriate corrective action.

Testing a cable string

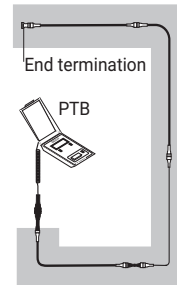

Testing an individual length of cable

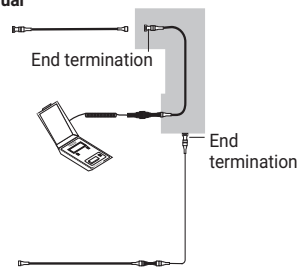

Method with Ohmmeter

1. Ensure the end termination is connected to the sensing cable. If checking several lengths of sensing cable in series (a cable string), ensure they are all connected.
2. Connect a Modular Leader Cable (TT-MLC-MC) to the sensing cable.
3. **Verify that the sensing cable is intact:**
 - Loop 1: Measure the resistance between the yellow and black wires of the leader cable as illustrated.
 - Loop 2: Measure the resistance between the red and green wires of the leader cable.

The readings should roughly equal a multiple of the length of sensing cable:

2.5 times the length of sensing cable (in ft) or 8.2 times the length of sensing cable (in m)

Example: 2.5 x 50 ft of cable = 125 Ω
8.2 x 15 m of cable = 123 Ω

In addition, the resistance of the two loops should be within 5 percent of each other.

If the cable string is not intact, apply this test procedure to segments of the system to identify the open connection or damaged modular length.

Note: If a heat-shrink tube must be removed to access a connector, refer to Oversleeve Removal Instructions (H54258).
4. **Check the condition of the sensing cable.** Measure the resistance between the black and green wires of the leader cable. If the reading is below 20 megohms, apply this test procedure to segments of the system to identify the modular sensing cable length(s) affected, locate the liquid or contamination, and take appropriate corrective action.

Testing a cable string

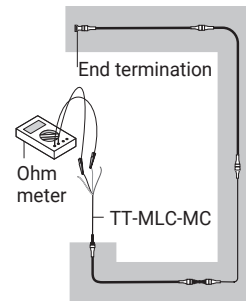

Testing an individual length of cable

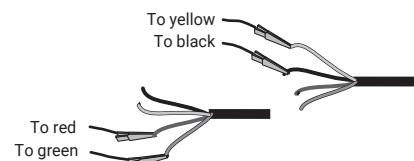
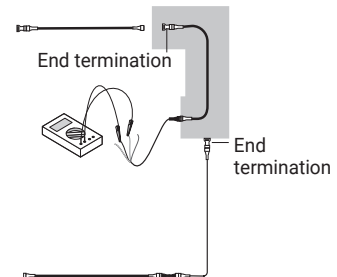

Complete System Connections and Layout

- A. TT7000-HUV is available in a variety of pre-cut and terminated lengths. Each cable has a female metal connector on one end and a male metal connector on the opposite end. Cable sections plug together like extension cords.
- B. (Optional) A branch connector (TT-MBC-MC-TW) is used to connect and branch "T" lines. The branch connector has one male connector and two female connectors. For mapping purposes, the cable connected to the center leg of the branch connector will be counted first, then the distance measurements will continue from the second female connector and continue along the rest of the system. A dead band of 24 ft (7.3 m) is inserted at the beginning and end of each branch to avoid any location ambiguity.
- C. (Optional) It is permissible to have multiple sub-branches as needed to fully trace the pipe system.
- D. Install an end termination (TT-MET-MC) at the end of the main line and each branch line. (Note: A good check on the system design and bill of materials is that the total number of end terminations installed in the system should equal the number of branch connectors plus one).
- E. (Optional) Install jumper cables (TT-MJC-xx-MC-BLK) as needed to connect sensing cable sections if they are spatially separated. Jumper cable is available in various pre-cut and terminated lengths and is also available in bulk form for long distance runs between the sensor cable and the instrumentation point.
- F. Install a leader cable (TT-MLC-MC-BLK) between the sensor cable and the monitoring instrument. The factory standard length of leader cable is 12 ft (4 m). It has a female metal connector on one end and four tinned leads on the opposite end for connection at the instrument's sensor cable terminal block. In some installations the distance between the instrument and the start of the sensor cable run will be much greater than 12 feet. In those cases a simple solution is to purchase a jumper cable of sufficient length, then cut off and discard the male connector and any extra cable. Bulk jumper cable and splicing kits are also available for lengths that exceed the longest available standard jumper cable.
- G. Use tie-wraps to neatly coil and secure any excess sensor cable, jumper cable, branch connectors, etc.

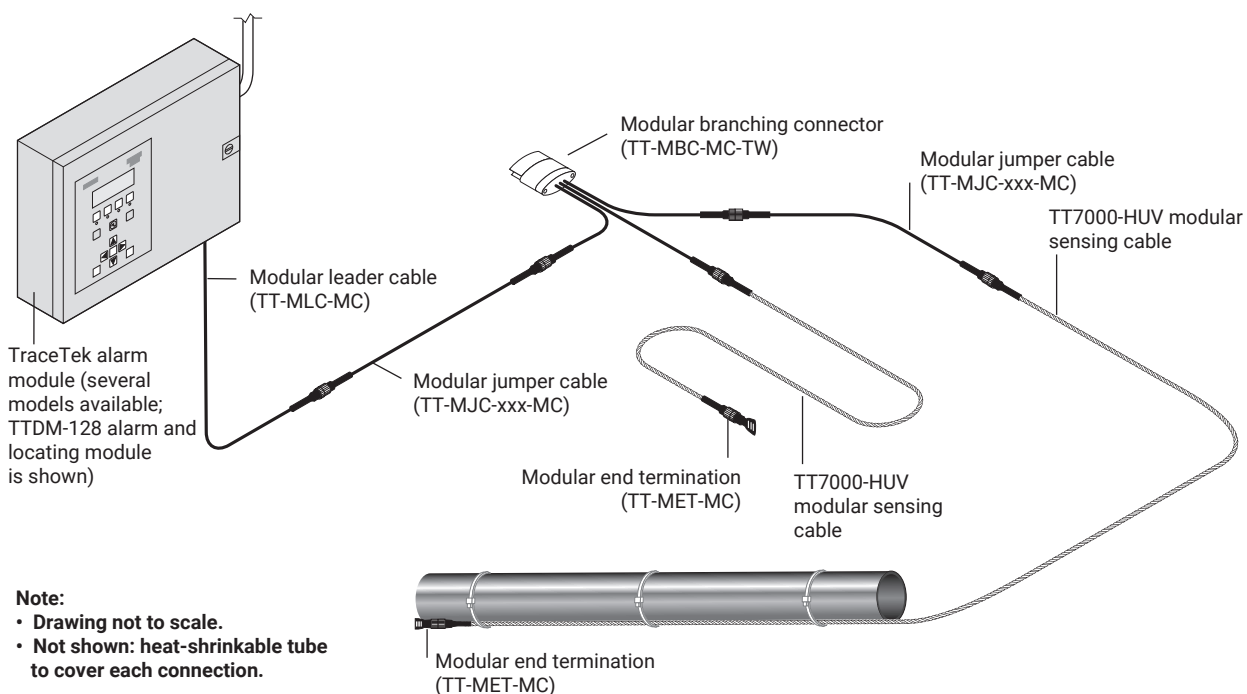

Initial Power-up and Test

Connect the cable to the selected alarm module and test the system.

- Apply power to the TraceTek alarm module and look for a “Normal” indication.
 - On TTC-1 there will be a green LED and no other red or yellow LEDs.
 - On TTSIM-1, Normal Condition is indicated by a steady green LED and a momentary flash of the RED LED every 10 seconds.
 - On TTDM-128 the alpha-numeric display will indicate a channel number and display the words SYSTEM NORMAL.
- If the Yellow LED is on in any of these alarm modules or the words “Cable Break” or “Loop Break” is displayed, then the cable system must be inspected for loose connections, missing end terminations until the cable continuity is established and the “Normal” condition is achieved.
- LEAK testing should be done with a mapping cap (TT-MAPPING CAP-MC). The MAPPING CAP simulates a leak at the location where it is inserted into the system.
 - For TTC-1 and TTSIM-1 a red LED will indicate that the simulated LEAK has been detected.
 - For TTDM-128 a leak location will be displayed in feet or meters (as selected) in addition to the red LED indication
- For larger piping systems with TTDM-128, the MAPPING CAP should be moved sequentially to each accessible connector. Note the distance displayed on the as-built drawings. This will become the basis for the system map.

Note: Do not use acid to test the TT7000-HUV cable. The TT7000-HUV cable is not resettable after acid exposure. Leak testing should be done with a mapping cap (TT-MAPPING CAP-MC). The TT-MAPPING CAP-MC simulates a leak at the location where it is inserted into the system.

TTC-1



TTC-1 Indications:

LEAK LED	Red
CABLE BREAK LED	Yellow
Reset Button	Red
POWER LED	Green

TTSIM-1

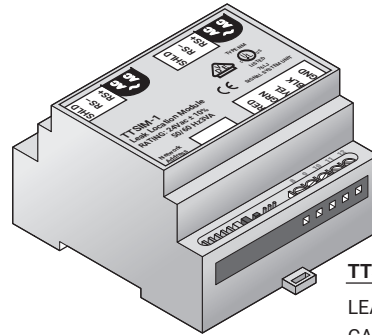

TTSIM-1 Indications:

LEAK	Red
CABLE BREAK	Flashing yellow
POWER LED	Green

TTDM-128

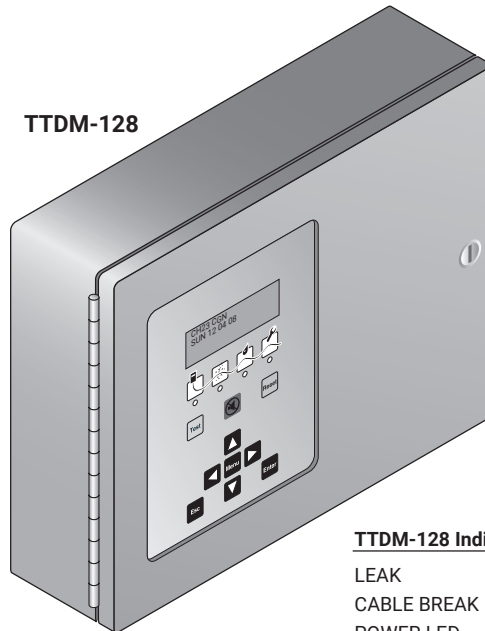

TTDM-128 Indications:

LEAK	Red
CABLE BREAK	Yellow
POWER LED	Green
Text message in 4x20 display	

Troubleshooting

Symptom	Possible Cause and Correction
Green LED not visible on TraceTek alarm module	System is not powered. Check power wiring. Check circuit breakers that may have been tripped. On TTDM-128 check fuse and replace if necessary.
Yellow LED visible on TTC-1 or flashing amber LED on TTSIM-1	Cable break indication. Check for loose connectors, missing end terminations, broken jumper wires or physical damage to the cable. Repair or replace cable if necessary. The TT-MET-MC (end termination) can be used to isolate a damaged section by working outward from the instrument using the end termination to establish a temporary end of the circuit then sequentially moving outward adding one cable segment at a time.
Red LED fails to turn off after leak reset attempted (sensing cable damaged by leak and requires replacement)	TT7000-HUV cannot be reset like other TraceTek cables. Once it has been exposed to acid of sufficient strength to cause an alarm it must be replaced. Damaged cable must be cut out of the system and replacement cable must be installed using factory standard lengths or sections of bulk cable and connector kits. In the event of an acid leak, examine the metal connectors on the sensing cable for possible corrosion. Also examine the wraps and related securing devices for possible damage and residual acid contamination. Replace any damaged components; thoroughly clean up all leaked acid to eliminate the risk of another sensor cable alarm from residual acid contamination related to the original leak.
RED LED cannot be turned off, despite initial replacement of damaged sensing cable	Examine cable for additional damage
Leak locations seem inaccurate or unstable during mapping tests	Make sure that the simulated leak (MAPPING CAP) is kept in place for at least 30 seconds. The location circuitry in the alarm modules require a steady leak location in order to compute an accurate distance. Removing the simulated leak mapping cap too quickly induces a large random error.
Leak location seems inaccurate in actual leak situation	TT7000-HUV requires special calibration of the leak location circuitry in TTSIM-1 or TTDM-128 alarm modules. The TT7000-HUV cable is different from other TraceTek sensor cables with regard to cable resistance per unit length. TT7000-HUV has a cable resistance of 2.5 Ω /ft (8.2 Ω /m), versus 3.9 Ω /ft (12.9 Ω /m) for other TraceTek sensor cables.
"SERVICE NEEDED" message (TTDM-128 Only)	This is an early warning message from the TTDM-128 panel indicating that the cable is becoming contaminated, but not yet to the level that constitutes a leak. The TTDM-128 panel may display a location in square brackets. If a location is displayed, that location should be investigated for possible low level acid contamination, damage or worn cable, etc. The square brackets indicated that the leak signal is not strong enough for an accurate location calculation, so the indicated locations may include some error. "Service needed" may temporarily appear at initial stage of leak detection with dilute acid and/or cold temperature.

North America

Tel +1 800 545 6258
info@chemelex.com

Latin America

Tel +1 713 868 4800
info@chemelex.com

Europe, Middle East, Africa, India

Tel +32 16 213 511
Fax +32 16 213 604
info@chemelex.com

Asia Pacific

Tel +86 21 2412 1688
infoAPAC@chemelex.com

chemelex
excellence is everything

Raychem Tracer Pyrotenax Nuheat