

TraceTek TT5000-HUV (for fuel leaks) TT5001-HUV (for solvent leaks)

TraceTek Sensing Cable for Above Ground Leak Detection Installation Instructions

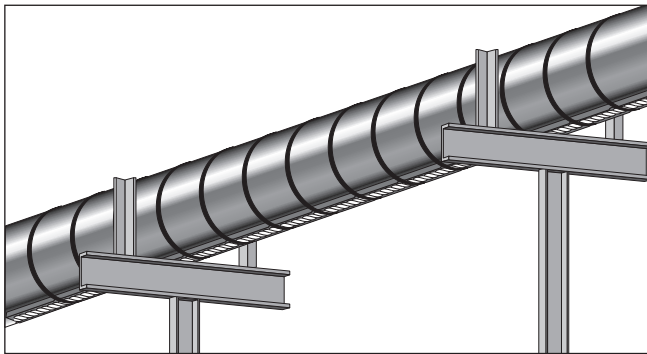

- TT5000-HUV sensing cable is identified by the red tracer in the black outer jacket.
- TT5001-HUV sensing cable is identified by the purple tracer in the black outer jacket.

Tools Required

Cutting shears	Shears with serrated blades
TraceTek TT-PTB-1000 (part # 486437-000)	Portable Test Box, battery powered instrument specifically designed for testing and trouble shooting TraceTek systems
Ohmmeter (>20 M ohm)	Can be used as an alternative and supplement to the PTB 1000
TraceTek TT-MAPPING CAP-MC (part # P000000871)	Used to simulate leaks at connector points during commissioning and mapping process
Extra TT-MLC-MC-BLK (part # 133332-000)	Leader cable. Used with the ohmmeter to make connections to the sensor cable for resistance measurements
Extra TraceTek TT-MET-MC (part # 571293-000)	End termination. Used during installation or trouble shooting to temporarily isolate a sub-section of sensor cable for resistance measurements.
TraceTek TT-ULTRA-TORCH (part # 390067-000)	Flameless heating tool (Ultratorch 200) or suitable heat gun with concentrator tip

DESCRIPTION

These instructions explain the proper procedures for installing and testing Raychem TraceTek TT500X-HUV sensing cables. (TT500X-HUV refers to either TT5000-HUV or TT5001-HUV). TT500X-HUV sensing cables are primarily intended for use on overhead piping, vertical pipe, valves and manifolds and other fittings where fuel or solvent could leak. TT500X-HUV sensing cables can also be used on floors, in drip pans, in sumps and trenches. TT500X-HUV sensing cables ignore water but will detect and locate fuel or solvent spills and leaks. (See the data sheet for specific performance characteristics.)

Important Notes

When used to monitor suspended or rack mounted pipe, TT500X-HUV sensing cables must be attached to the pipe system at the lowest point where any liquid leak is most likely to drip from the pipe. Usually this will be the 6 o'clock position on horizontal piping but other mounting locations and techniques may be necessary if site conditions are unusual. In particular, special consideration should be given to pipe supports, couplings, "T's", valves and other fittings. It is the responsibility of the installer to position the cable such that any leak will drip onto the cable.

TT500X-HUV sensing cables are designed for indoor or outdoor environments. The TT500X-HUV is a small diameter, flexible cable consisting of four wires wrapped around a central core. An outer layer rope-braid of synthetic fiber provides further protection from UV radiation. TT500X-HUV cable can be exposed to sunlight, rain, snow, fog, condensation, dust, blowing dirt and other contaminants without causing a false alarm.

REQUIRED MATERIALS

TraceTek TT-PU-FOAM-2x0.5 (part # P000001136)	2-inch wide foam with adhesive backing
TraceTek TT-VSTRAP-1.5x75FT (part # P000001135)	Fastening strap
Rags and appropriate cleaner	Use to wipe and clean bottom and side surfaces of pipe prior to cable installation
Heat shrink tubing segments	Used as environmental seal over all mated male/female (pin/socket) connections

OPTIONAL MATERIALS

TraceTek TT-MBC-MC-TW (part # P000001206)	Branch connector designed for rugged outdoor applications used to connect and branch "T" lines
TraceTek TT-MJC-XX-MC-BLK	Jumper cable is available in various pre-cut and terminated lengths
TraceTek TT5000-HUV-CK-MC-M/F (part # P000001207)	Connector kit used during field connection of TT5000-HUV bulk cable

⚠ GENERAL NOTES: DO'S AND DON'TS:

DO:

- Store the cable in its original container in a clean, dry area until ready to install.
- Clean the pipe surface where the cable will be installed.
- Schedule the sensor cable installation as late as possible in the construction schedule to avoid risk of damage or contamination by other contractors or construction tasks.
- Remove cable from the pipe if any thread cutting, welding, soldering or similar pipe fitting work will be performed.

DON'T:

- Drag the cable through water, paint, solvents, oil or other contaminants.
- Install damaged or contaminated sensing cable.
- Exceed the maximum pulling force of 100 kg (220 lb).
- Use the cable as a rope for lifting or securing any object.
- Allow tools or heavy objects to fall on cable.
- Exceed 3300 ft (1000 m) of individual sensor cable circuit length when using a SIM alarm module.
- Test the cable with fuel.
- Use tie wrap or wire to secure the cable.

INSTALLATION

1

Clean and prepare the pipe or area where the cable will be installed.

- Verify that major construction is complete.

Clean the bottom and sides of the pipe where the cable will be installed to remove any residual oily waste or contaminant

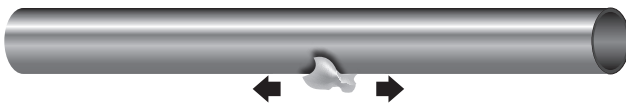

2

Check each length of connectorized sensing cable before installation.

- To ensure that each length of sensing cable is intact and free of contamination, follow the Sensing Cable Test Procedure. Do not use damaged or contaminated sensing cable.

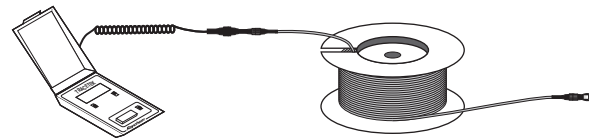

Bulk (unconnectorized) cable will be checked during the connectorization process.

- Observe the do's and don'ts under "General Notes" on page 3 of these instructions; take care to avoid damaging or contaminating sensing cable.

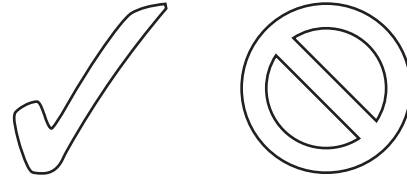

3A

For connectorized cable connect a Modular End Termination (TT-MET-MC) to the first sensing-cable length to be installed.

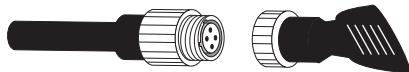

3B

For connectorized cable orient sensing cable so the connector used with the end termination will be the furthest away from connection to the TraceTek alarm module. Work out from the alarm module connection.

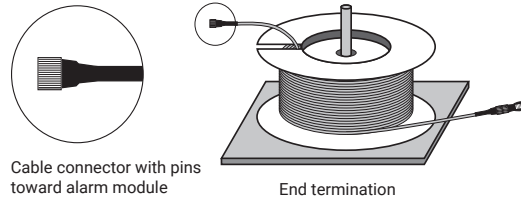

For bulk (unconnectorized) cable, orientation does not matter for this step.

For sensing cable on reels (lengths over 10 feet [3 m]), put the reel on an axle and pull the cable out.

Install sensing cable in accordance with the leak detection layout plan.

- Verify the pipe bottom has been cleaned and dried to ensure proper adhesion of the foam strip to the pipe.
- Verify sufficient stock of Adhesive Foam Strip on hand for job (TT-PU FOAM-2X0.5 part # P000001136). Plan on about the same length of foam strip as sensing cable to be installed.
- Verify sufficient stock of Fastening Strap on hand for job (TT-VSTRAP-1.5X75FT part # P000001135). Plan on four times the pipe diameter for each strap. Desired strap overlap is 25%.
- For each length of sensing cable to be installed, prepare an adhesive foam strip of corresponding length. Install the foam first, then the sensing cable.
- Best results are obtained from completely installing one section of foam/sensing cable/strap before moving on to the next section.
- Align a short section of foam strip along the bottom of the pipe at the 6 o'clock position. The foam strip is 2-inch wide, to provide some tolerance for minor misalignment. The foam acts as a sponge to soak up leaking liquid as it reaches the bottom area of the pipe, to enhance the ability of the sensor cable to detect a leak.
- Install the foam strip by removing the release paper covering the adhesive. Do not remove excessive lengths of release paper, as the adhesive may become dirty. It is better to remove short sections of release paper. Starting at one end of the foam strip, press the adhesive side firmly onto the pipe, then remove another short section of the release paper and repeat the process. Be careful to maintain the centerline of the foam strip at the 6 o'clock position on the pipe.
- After a foam strip segment has been secured against the pipe, take the sensor cable and position it at the 6 o'clock position on the pipe (should be in the center of the foam strip). Position the cable to be snug against the foam, with no visible sag.
- Secure the cable against the pipe with the fastening strap. The preferred strap method places the soft side of strap against the sensing cable. Use a strap overlap position at the top of the pipe. Place one end of strap at top of pipe. Wrap the strap around the pipe. Before cinching the strap into final position, verify the sensing cable is at 6 o'clock position. Then press the free end of strap firmly into the captive end of strap—make sure strap has no air gaps within connected surfaces. The strap should be applied with about a 25% overlap of the free end over the captive end.

- Use one fastening strap every 18 to 20 inches of pipe length (450 to 500 mm) with extra straps used at fittings or bends as needed to maintain a snug fit of the sensor cable against the pipe.
- After every 5 strap applications, remove any excess slack in the sensing cable.
- Around flanges, to enhance leak detection apply foam around the bottom half of the flange to absorb potential leaks. Then run the sensing cable across the foam at the bottom of the flange at the 6 o'clock position.

Note: Do not use nylon or steel tie wraps to secure the sensor cable—this will result in false leak alarms.

Important: It is the installer's responsibility to position the sensor cable correctly. The cable must trace the lowest point of the pipe or fittings such that any liquid leaking from the pipe or fittings will drip onto the cable surface as it drips off the bottom of the pipe or fitting. Do not install the cable on the top or side surface of a pipe. Do not spiral the cable on horizontal pipe.

Exception: If the cable is used to trace vertical pipe, the cable should be spiraled around the pipe and secured with fastening straps.

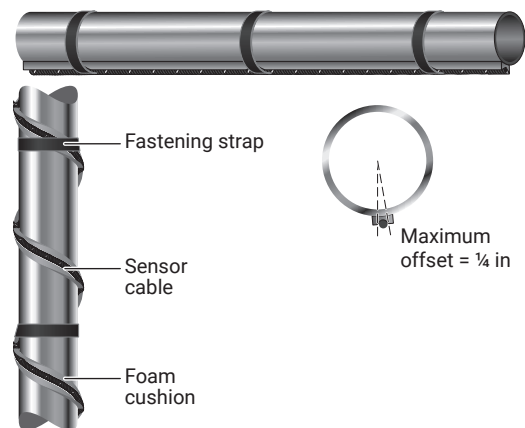

Connectorization procedure for bulk cable

Bulk (unconnectorized) cable is generally connectorized after fastening cable to pipe. Refer to TraceTek document H54830 for detailed instructions regarding connectorization procedures. If bulk cable is cut and connectors will not be immediately installed, use shrink tubing or tape the cable ends to protect cable integrity (water/physical damage).

Test each length of connectorized sensing cable after installing it and before attaching it to cable already installed. Confirm that the sensing cable is clean and intact by following the Sensing Cable Test Procedure.

Prior to installing a new length of sensor cable, push heat shrinkable tube onto the cable. Connect the sensing cable to the cable circuit (lengths of sensing cable connected in series) previously installed.

- Mark the connector position on the layout plan.
- Install Raychem TraceTek mapping tag (TT-TAG).
- **Note:** As an extra precaution on large installations, periodically test the entire cable circuit to confirm that all installed sensing cable is still clean and intact.
- Unplug the end termination and connect it to the next length of sensing cable to be installed.

Repeat the installation sequence for each length of cable.

Complete the system

1. Install other TraceTek components (such as Modular Branching Connectors, Weighted Lengths, and Modular Jumper Cables) as called for in the system layout. Complete the sensing circuit.

Note: All components of the system have male or female metal connectors or both. The male connectors are oriented toward the instrument panel. As new sections of cable are added to the main leg or branch, each newly added section should end with an open female connector. The end of each branch or main leg is terminated with a male end termination.

2. Test the sensing circuit (or portions of it) to confirm that the sensing cable is clean and intact. Follow the Sensing Cable Test Procedure.
3. Locate the unlabeled heat shrink tubing segment (delivered along with the TT500X-HUV connectorized cable, or as part of the TT5000-HUV-CK-MC-M/F connector kit.) Install the heat shrink tube as environmental seal over all mated male/female (pin/socket) connections.

- Center the unlabeled shrink tube over the pin/socket connection. Heat shrink the tube over the connection, beginning in the center and shrinking towards the ends until the tube fully conforms to the shape of the connection and adhesive flows from each end of the tube.

CAUTION: Burn Hazard. Do not get hot adhesive on your bare skin. The hot adhesive will burn your skin.

- Avoid overheating the thin wall unlabeled shrink tubing. The thin wall tubing requires less heat than the SCT cable shrink tubing.

- Let the entire connector area cool before handling the cable.

Note: Do not leave connector open to environment. If the connector becomes wet or contaminated, it will need to be replaced.

Note: When arranging any TT500X-HUV cables do not use a bend radius less than 2 in. (51 mm).

Note: If a heat-shrinkable tube must be removed (for example, for cable testing), refer to Oversleeve Removal Instructions (H54258).

4. Connect the sensing circuit to the TraceTek alarm module and activate the system as soon as is practical. Use the alarm module to monitor for events during the final stages of construction.

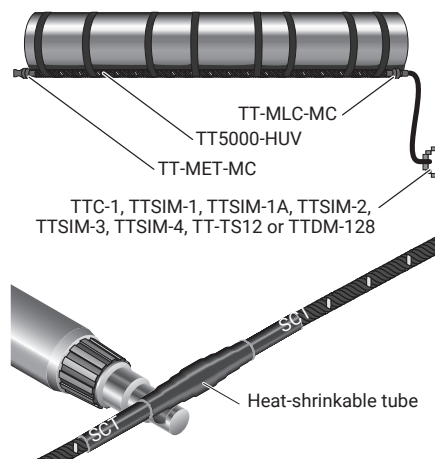

WARNING:

Fire Hazard. Heat guns and flameless heating tools can cause fire or explosion in hazardous areas. Be sure there are no flammable materials or vapors in the area before using these tools. Follow all site safety guidelines when working in hazardous areas.

Component approvals and performance are based on the use of specified parts only.

CAUTION:

Health Hazard. Overheating heat-shrinkable tubing will produce fumes that may cause irritation. Use adequate ventilation and avoid charring or burning. Consult MSDS RAY3122 for further information.

CHEMTREC 24-hour emergency telephone: (800) 424-9300

Non-emergency health and safety information: (800) 545-6258.

Take precautions if installation is incomplete at end of work day.

At the end of the work day:

- Ensure that there are no exposed connectors. Each sensing cable should be connected to a Modular Leader Cable (TT-MLC-MC), Modular End Termination (TT-MET-MC), and/or other sensing cables; check both ends of the cable.
- Test and record the condition of installed sensing cable following the Sensing Cable Test Procedure.
- If practical, connect the installed sensing cable to the TraceTek alarm module. Test the system and put it in operation following the alarm module installation instructions.

At the beginning of the next work day:

- Check that the installed sensing cable is clean and intact following the Sensing Cable Test Procedure. Compare the results with those obtained at the end of the previous work day. If necessary, investigate and correct problems before proceeding.

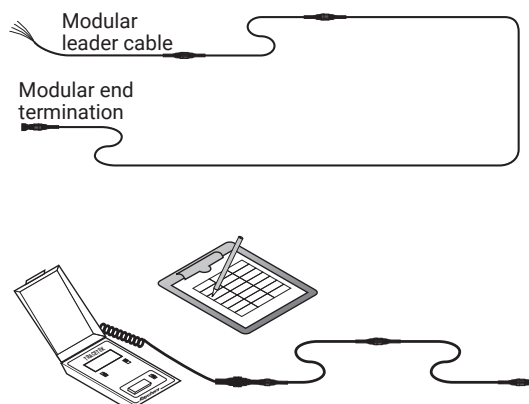

SENSING CABLE TEST PROCEDURE

Method with Raychem TraceTek Portable Test Box (TT-PTB-1000)

1. Ensure the end termination is connected to the sensing cable. If checking several lengths of sensing cable in series (a cable string), ensure they are all connected.
2. Connect the PTB to the sensing cable(s) using its adapter, as illustrated.
3. **Verify that the sensing cable is intact;** follow the operating instructions printed inside the lid of the PTB itself. If a cable or connection is broken, the PTB illuminates its LED indicating "cable break," and displays a "1" in the leftmost position of its LCD display. If the cable string is intact, the PTB measures the system length.
 - If the cable string is not intact, apply this test procedure to segments of the system to identify the open connection or damaged modular length.
 - **Note:** If a heat-shrink tube must be removed to access a connector, refer to Oversleeve Removal Instructions (H54258).
4. **Check the condition of the sensing cable(s),** again following the PTB operating instructions. If the sensing cables are clean and free of contamination, the current measured should be $0 \mu\text{A}$. If the reading exceeds $10 \mu\text{A}$, use the PTB to locate the liquid or contamination and take appropriate corrective action.

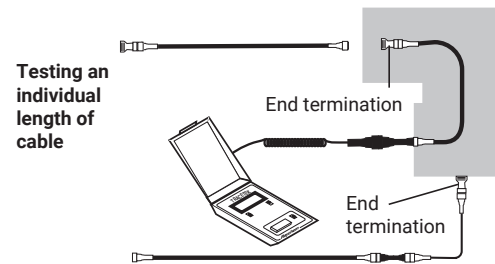
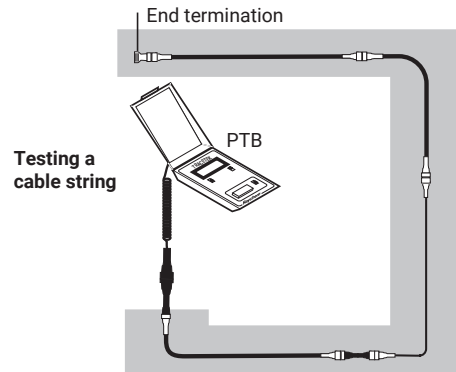

Method with Ohmmeter

1. Ensure the end termination is connected to the sensing cable. If checking several lengths of sensing cable in series (a cable string), ensure they are all connected.
2. Connect a Modular Leader Cable (TT-MLC-MC) to the sensing cable.
3. **Verify that the sensing cable is intact:**
 - Loop 1: Measure the resistance between the yellow and black wires of the leader cable as illustrated.
 - Loop 2: Measure the resistance between the red and green wires of the leader cable.

The readings should roughly equal a multiple of the length of sensing cable:

4.0 times the length of sensing cable (in feet), or 13.1 times the length of sensing cable (in meters).

Example: $4.0 \times 50 \text{ ft of cable} = 200 \Omega$
 $13.1 \times 15 \text{ m of cable} = 197 \Omega$

In addition, the resistance of the two loops should be within 5 percent of each other.

If the cable string is not intact, apply this test procedure to individual segments of the system to identify the open connection or damaged modular length.

Note: If a heat-shrink tube must be removed to access a connector, refer to Oversleeve Removal Instructions (H54258).

4. **Check the condition of the sensing cable.** Measure the resistance between the black and green wires of the leader cable. If the reading is below 20 megohms, apply this test procedure to individual segments of the system to identify the modular sensing cable length(s) affected, locate the damage or contamination, and take appropriate corrective action.

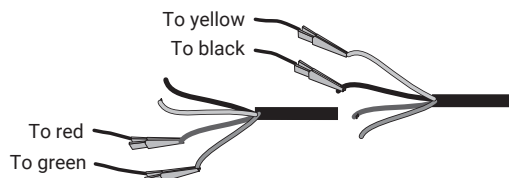
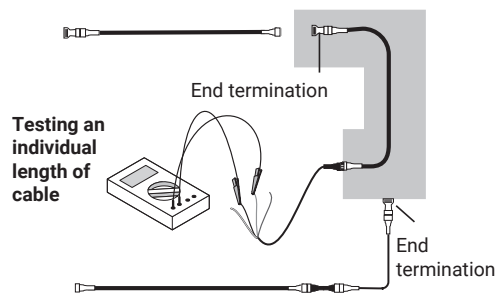
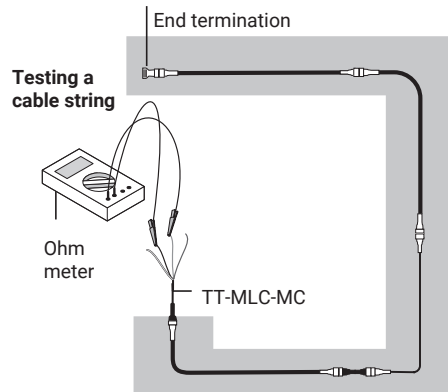

COMPLETE SYSTEM CONNECTIONS AND LAYOUT

- A. TT500X-HUV is available in a variety of pre-cut and terminated lengths. Each cable has a female metal connector on one end and a male metal connector on the opposite end. Cable sections plug together like extension cords.
- B. (Optional) A branch connector (TT-MBC-MC-TW) is used to connect and branch "T" lines. The branch connector has one male connector and two female connectors. For mapping purposes, the cable connected to the center leg of the branch connector will be counted first, then the distance measurements will continue from the second female connector and continue along the rest of the system. A dead band of 16 ft (5 m) is inserted at the beginning of each branch to avoid any location ambiguity.
- C. (Optional) It is permissible to have multiple sub-branches as needed to fully trace the pipe system.
- D. Install an end termination (TT-MET-MC) at the end of the main line and each branch line. (Note: A good check on the system design and bill of materials is that the total number of end terminations installed in the system should equal the number of branch connectors plus one).
- E. (Optional) Install jumper cables (TT-MJC-xx-MC-BLK) as needed if they are to connect sensing cable sections in separate areas. Jumper cable is available in various pre-cut and terminated lengths and is also available in bulk form for long distance runs between the sensor cable and alarm module location.
- F. Install a leader cable (TT-MLC-MC-BLK) between the sensor cable and the alarm module location. The factory standard length of leader cable is 12 ft (4 m). It has a female metal connector on one end and four tinned leads on the opposite end for connection at the alarm module terminal block. In some installations the distance between the alarm module and the start of the sensor cable run will be much greater than 12 feet. In those cases a simple solution is to purchase a jumper cable of sufficient length, then cut off and discard the male connector and any extra cable. Bulk jumper cable and splicing kits are also available for lengths that exceed the longest available standard jumper cable.
- G. Use fastening straps to neatly coil and secure any excess sensor cable, jumper cable, branch connectors, etc.

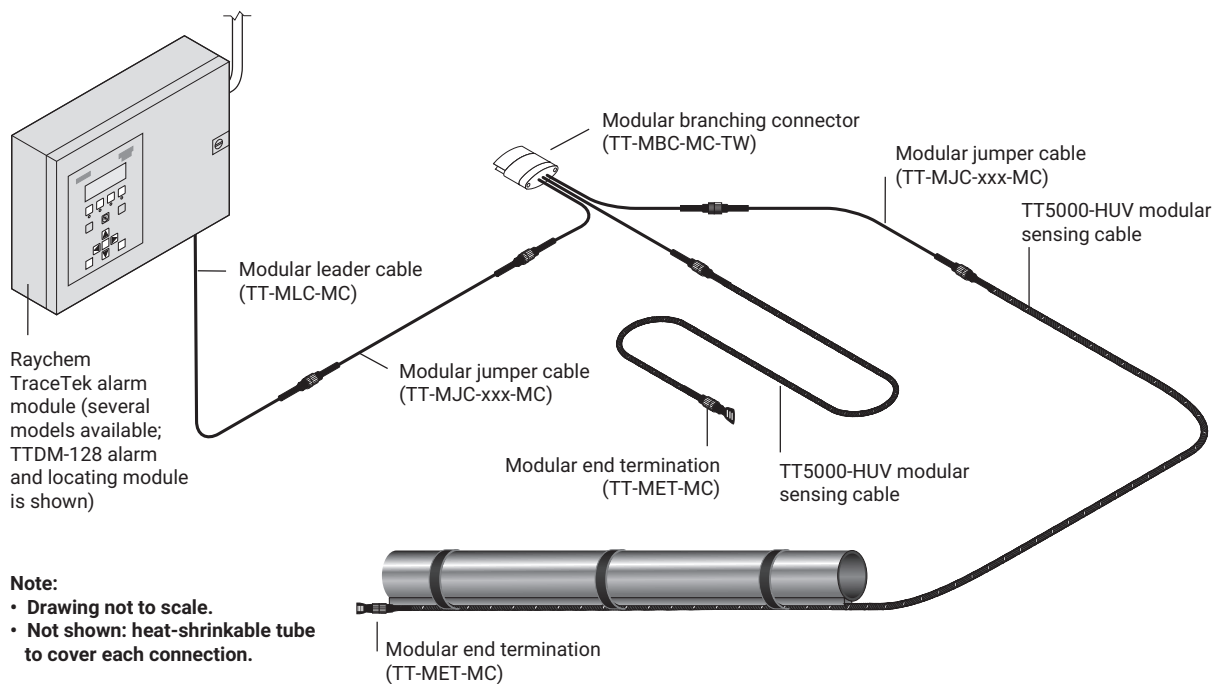

INITIAL POWER-UP AND TEST

Connect the cable to the alarm module and test the system.

- Apply power to the TraceTek instrument and look for a "Normal" indication.
 - On Raychem TraceTek TTC-1, TTSIM-1A, TTSIM-2, TTSIM-3 or TTSIM-4, Normal Condition is indicated by a green LED. (On TTSIM-1A and TTSIM-2 the green LED will flicker off every 5 seconds.)
 - On Raychem TraceTek TTSIM-1, Normal Condition is indicated by a green LED and a momentary flash of the RED LED every 5 seconds.
 - On TTDM-128 the alpha-numeric display will indicate a channel number and display the words SYSTEM NORMAL.
- If the Yellow LED is on in any of these instruments or the words "Cable Break" or "Loop Break" is displayed, then the cable system must be inspected for loose connections, missing end terminations until the cable continuity is established and the "Normal" condition is achieved.
- Leak testing can be done with a mapping cap (TT-MAPPING CAP-MC) or by bending the sensor cable tightly between fingers. The MAPPING CAP simulates a leak at the location where it is installed in the system.
 - For TTC-1, TTSIM-1, TTSIM-1A, TTSIM-2, TTSIM-3 and TTSIM-4, a red LED will indicate that the simulated LEAK has been detected.
 - For TTSIM-2, TTSIM-3-LVS or -HVS, and TTDM-128, a leak location will be displayed in feet or meters (as selected) in addition to the red LED indication.
- For larger piping systems with TTDM-128 or TTSIM-2, the MAPPING CAP should be moved sequentially to each accessible connector. Record the distance displayed on the as-built drawings. This will become the basis for the System Map.
- Create a System Map showing where sensing cables and alarm modules have been installed. The System Map will include the beginning and end of sensing cables, and location of any connections. If using locating alarm modules, the System Map should include distance readings at significant landmarks (beginning and end of system, changes of direction, branches, valves, low points, etc.).

Note: Do not use fuel to test the TT5000-HUV cable. Do not use solvent to test the TT5001-HUV cable. The TT500X-HUV cable is not resettable after exposure. Leak testing should be done, by bending sensor cable tightly between fingers, or with a mapping cap (TT-MAPPING CAP-MC). The TT-MAPPING CAP-MC simulates a leak at the location where it is installed in the system.

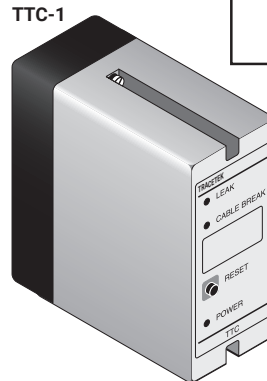
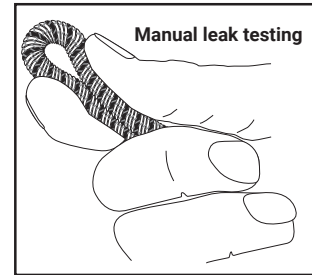

TTC-1 Indications:

LEAK LED	Red
CABLE BREAK LED	Yellow
Reset Button	Red
POWER LED	Green

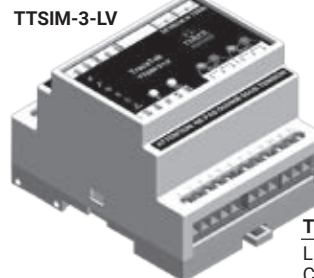

TTSIM-3-LV Indications:

LEAK	Red
CABLE BREAK	Yellow
SERVICE	Yellow
POWER LED	Green



TTSIM-3-LVS Indications:

LEAK	Red
CABLE BREAK	Yellow
SERVICE	Yellow
POWER LED	Green
Leak location shown on display	

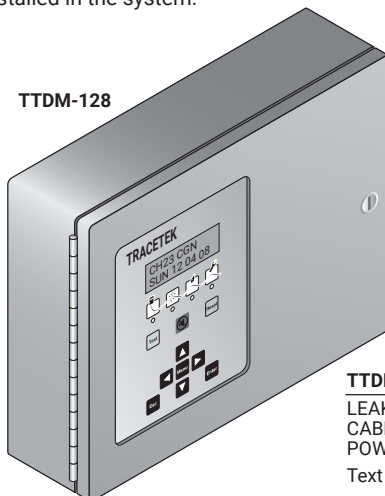

TTDM-128 Indications:

LEAK	Red
CABLE BREAK	Yellow
POWER LED	Green
Text message in 4x20 display	



TTSIM-4-LV Indications:

LEAK	Red
CABLE BREAK	Yellow
SERVICE	Yellow
POWER LED	Green

TROUBLESHOOTING

Symptom	Possible Cause and Correction
Green LED not visible on TraceTek instrument	System is not powered. Check power wiring. Check circuit breakers that may have been tripped. On TTDM-128 check fuse and replace if necessary.
Leak alarm (TTDM-128 message and red LED) (TTSIM's Red LED ON)	<p>This is an indication of a LEAK event.</p> <p>For leak locating modules (TTDM-128, TTSIM-2, TTSIM-3-LVS, or TTSIM-3-HVS): Using leak distance indication and System Map as a guide, investigate system condition, work to locate and repair leak.</p> <p>For non-locating modules: Work to locate and repair the leak. (If your system is constructed with multiple sensor cable segments, using an end termination (TT-MET-MC) to break the system into sections can help in locating the leak. Work outward from the alarm module using the end termination to establish a temporary end of the circuit, then sequentially move outward adding one cable segment at a time).</p> <p>TT500X-HUV cannot be reset like other TraceTek cables. Once the cable has been exposed to fuel (for TT5000-HUV) or solvent (for TT5001-HUV) it must be replaced. Damaged cable must be cut out of the system and replacement cable must be installed using factory standard lengths or sections of bulk cable and connector kits.</p> <p>In the event of a leak, examine the metal connectors on the sensing cable for possible corrosion. Also examine the fastening straps and adhesive foam strips for residual contamination. Replace any damaged components; thoroughly clean up all leaked liquid to eliminate the risk of another sensor cable alarm from residual contamination.</p> <p>Note: When the Service Req'd or SERVICE condition exists (Yellow LED), leak location accuracy is reduced for a new leak.</p>
Yellow LED visible on TTC-1 or any TTSIM's	<p>Could be cable break or service indication. Refer to alarm module instructions for more information.</p> <p>For Cable break indication: Check for loose connectors, missing end terminations, broken jumper wires or physical damage to the cable. Repair or replace cable if necessary. The TT-MET-MC end termination can be used to isolate a damaged section by working outward from the instrument using the end termination to establish a temporary end of the circuit then sequentially moving outward adding one cable segment at a time.</p>
"SERVICE Req'd" message (TTDM-128 Only)	This is an early warning message from the TTDM-128 panel indicating there is current leakage, but not yet to the level that constitutes a leak. The TTDM-128 panel may display a location in square brackets. If a location is displayed it should be investigated for possible sources of kinks or pinches. The square brackets indicate that the leak signal is not strong enough for an accurate location calculation, and may include some error.
Red LED fails to turn off after leak is repaired, and leak alarm reset attempted	Examine cable for additional damage or leaks.
Leak location seems inaccurate in actual leak situation	More than one leak may be present or the cable may be wetted in several locations. If the system is monitored by a TTDM-128, check the event history to see if there is an earlier indication of a nearby leak or a SERVICE NEEDED message. If necessary use the end termination to break the system into smaller segments and work outward to isolate each leak location in multiple leak scenarios.
Leak locations seem inaccurate or unstable during mapping tests	Make sure that the simulated leak produced by tightly bending the sensor cable or use of TT-MAPPING CAP-MC is kept in place for at least 30 seconds. The location circuitry in the instruments require a steady leak location in order to compute an accurate distance. Removing the simulated leak too quickly induces a random error.

North America

Tel +1 800 545 6258
info@chemelex.com

Latin America

Tel +1 713 868 4800
info@chemelex.com

Europe, Middle East, Africa, India

Tel +32 16 213 511
Fax +32 16 213 604
info@chemelex.com

Asia Pacific

Tel +86 21 2412 1688
infoAPAC@chemelex.com

chemelex
excellence is everything

Raychem

Tracer

Pyrotenax

Nuheat